

# ***HYDRA 985***



The information, specifications, and illustrations in this manual are on the basis of information available at the time it was written. The specifications, torque values, pressures of operation, measurements, adjustments, illustrations, and other items can change at any time. These changes can affect the service of the given product.

For the complete and most current information, contact:

Hogg & Davis, Inc  
P.O. Box 405 / 3800 Eagle Loop  
Odell, OR 97044-0405  
541-354-1001  
541-354-1080 Fax

**For most recent manual  
version please visit:**

**[www.hoggdavis.com](http://www.hoggdavis.com)**

# HYDRA 985

## Contents

PRODUCT WARNINGS .....	4
OPERATIONS .....	5
DIESEL ENGINE SPECIFICATIONS .....	6
INTRODUCTION.....	6
GENERAL SPECIFICATIONS.....	6
TRAILER ORIENTATION.....	8
MAIN FRAME AND AXLE .....	8
CONTROLS.....	9
LOADING INSTRUCTIONS .....	10
HYDRAULIC CONTROLS .....	11
Power Unit Features .....	11
FRONT HYDRAULIC CONTROLS .....	12
FRONT CONTROL BANK.....	13
REEL CARRYING RACKS (MANDREL RACKS) .....	14
POWERED IDLER WHEELS AND HYDRAULIC CONTROLS.....	14
AUXILIARY POWER SHAFT .....	14
POWER UNIT .....	14
JACKSTANDS.....	15
STEER-GO OPERATION .....	16
MANUVERING INSTRUCTIONS.....	16
TO STEER AND MOVE.....	17
THE JOYSTICK .....	17
ON BOARD AIR COMPRESSOR.....	18
BRAKE CONTROLLERS.....	18
TOOL CIRCUIT (OPTIONAL).....	19
LEVELWIND OPERATIONS .....	20
LEVELWIND COMPONENTS.....	21
PULLING PROCEDURES.....	22
OVERHEAD WIRE.....	22

# HYDRA 985

UNDERGROUND PULLING .....	23
SERVICE .....	24
HYDRA 985 Lubrication .....	25
JACKSTAND INSTALLATION .....	26
DRIVE ROLLER MAINTENANCE .....	27
DRAWDAR INSPECTION .....	28
ACME ADJUSTING SCREW .....	28
MANDREL RACK STABILIZER INSTALLATION .....	29



# HYDRA 985

## PRODUCT WARNINGS

These warning labels and others like it are placed in critical areas of the machine. The warnings are to be read and fully understood prior to operation of the unit.



### LOADING INSTRUCTIONS

**IMPORTANT:** This unit is designed to load a reel that is setting on the ground. **DO NOT LOAD WITH FORKLIFT** or other device as this causes cable damage and can effect the safe carrying procedures of this unit. **FOLLOW DIRECTIONS.**

**LOADING PROCEDURE**

1. The fully AWL wheel base of 80" to 100" in diameter and 20" minimum to 30" maximum width.
2. To load, make sure power moving unit is stopped at an available:
3. Lower handle of the hoist.
4. Put out spools of the cable, remove the end of the cable and the end of the cable.
5. If the cable is over 2" (50mm) in diameter, use the cable to pull the cable.
6. Always use proper technique in the use of the unit and do not exceed its limits.
7. Install lock bolts in each side of reel.
8. Place bearing on ends of reel.
9. Roll reel into unit or back-end assembly and rear spring track. Insert the reel into the rear spring track.
10. Put bearing back in place on each end of reel to back bearing.
11. Insert the reel into the rear spring track and bearing track.
12. Set the reel locks - one on each end. These are located at rear of spools. Push handle down to engage.
13. Make sure unit is fully up to place.
14. Lower reel with both hoists and hold for 10 seconds to take heat off the hoist system. Reel should be fully on hoist.
15. Adjust each end of the cable to center of reel flange.
16. See 1987140000 for adjusting cables in the rear of the unit.
17. When done, and operator has finished, bring the unit.

**BEFORE TOWING VEHICLE**

**NOTE:** With reels that have a single spoke foot allowing following, base spoke in vertical position before moving power and against flange.

**HD**  
HOGG & DAVIS, INC.

# OPERATIONS



# HYDRA 985

## INTRODUCTION

The Hogg & Davis, Inc **HYDRA 985** Cable Reel Unit is an advanced design cable pulling trailer that provides tremendous pulling forces in a compact vehicle. Its total design provides for easy operations and affords great savings in set-up and manpower. Full utilization of the **HYDRA 985** will greatly improve your cable installation and removal operations.

This manual is designed to make you familiar with the machine and its operation.

READ THIS MANUAL THOROUGHLY BEFORE OPERATING THE MACHINE

## GENERAL SPECIFICATIONS.

- REEL CAPACITY: 108" dia X 56" wide
- HYDRAULIC REEL LIFTING CYLINDERS
- HYDRAULIC POWERED IDLER WHEEL
- HYDRASTATIC TRANSMISSION POWER UNIT
- CADMIUM PLATED, QUICK RELEASE JACKSTANDS
- 20,000 STUB STPINDLE AXLE
- AIR BRAKES w/ABS
- 2.5" REEL MANDREL WITH TAPERED CENTERING CONES, LOCKING COLLARS, AND NYLATRON BEARINGS

## DIESEL ENGINE SPECIFICATIONS

### 3TNV88-BDSA General

#### Specification

**36.0 HP (26.9 kW) @ 3000 rated rpm\***

**Type** ••••• 3 Cylinder, 4-Cycle, Liquid Cooled Diesel Engine

**Bore** ••••• 88 mm

**Stroke** ••••• 90 mm

**Displacement** ••••• 1.642 L

**Aspiration** ••••• Naturally Aspirated

**Combustion System** ••••• Direct Injection

**Rotation (from flywheel end)** ••••• Counterclockwise

**Dry Weight** ••••• 341 lbs (154 kg)

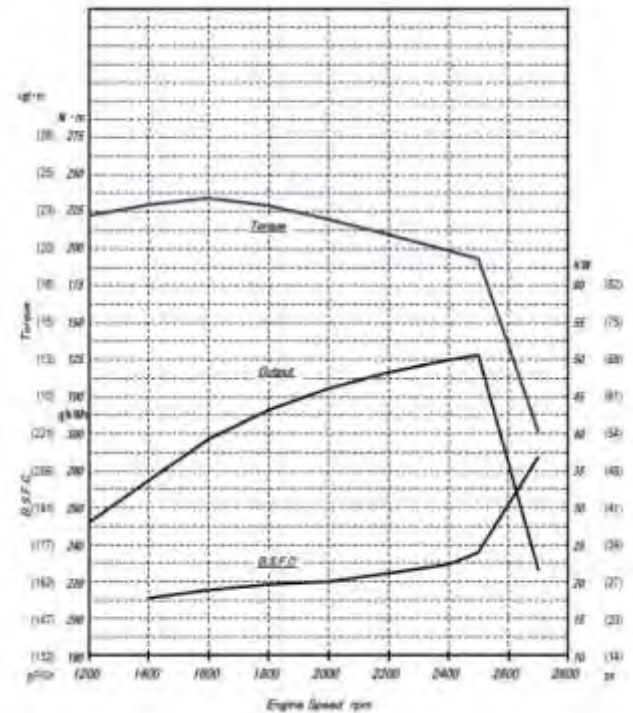

# HYDRA 985



INDUSTRIAL / ENGINES / TNY SERIES



### Dimensions, Performance Data & Quick Specs

<b>NET INTERMITTENT POWER (kW/hp)</b> Potencia Nets Intermitente	26.2 / 35.1
<b>RATED SPEED (RPM)</b> Velocidad de Regimen	3000
<b>LENGTH (w/fan) (in/mm)</b> Longitud	24.1 / 611 w/DPF
<b>WIDTH (in/mm)</b> Ancho	21.9 / 556 w/DPF
<b>HEIGHT (in/mm)</b> Altura	34.2 / 868 w/DPF

## 3TNV88C-DYEM

SPECIFICATION Especificacion	DYEM
<b>CYLINDERS</b> Cilindros	3
<b>BORE X STROKE</b> Diámetro x Carrera	88 x 90 (mm) 3.46 x 3.54 (in)
<b>DISPLACEMENT</b> Cilindrada	1642 (cc) 100.2 (ci)
<b>COMBUSTION TYPE</b> Tipo de Combustion	Common Rail Direct Injection Common Rail de Inyección Directa
<b>ASPIRATION</b> Aspiracion	Naturally Aspirated Aspiracion Natural
<b>GOVERNOR TYPE</b> Tipo de Gobernador	Electronic Control Electrónico

### Lubrication System

6.7L Capacity Deep Oil Pan

### Electrical System

12V, 65A Alternator

### Fuel System

Common Rail System

### Cooling System

Water Pump, Belt-driven

### Power Take Off

FWH: SAE #6 1-124

FW: SAE 7, 8"

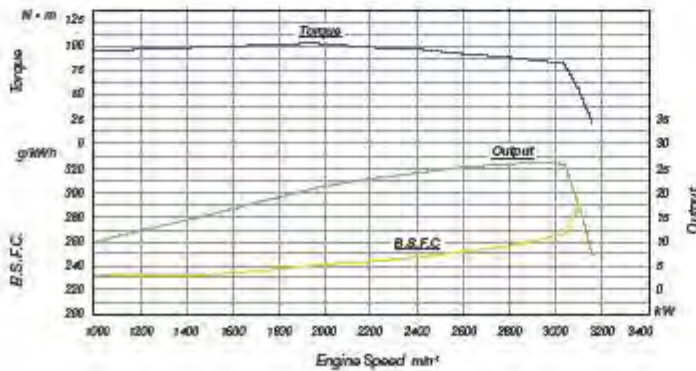

© 2016 Yanmar America Corp.  
Engine specifications are subject to change without notice.  
15-3TNV88C-DYEM-3000-11



# HYDRA 985

## TRAILER ORIENTATION

The HYDRA 985 is made up of four (4) major working components (see Fig.1) they are:

- A. MAIN FRAME AND AXLE
- B. POWER UNIT
- C. POWER IDLER WHEEL AND CONTROLS
- D. REEL CARRYING RACKS

## MAIN FRAME AND AXLE

The main frame and axle carry the entire weight of the trailer and its payload. Constructed of heavy steel, the main frame will provide many years of durable service and minimum maintenance. The fenders and tool compartments are incorporated as part of the main frame structure.

The axle is of the 20,000 lb capacity stub type. Heavy duty brakes, hubs and bearings provide many years of service over all highway types.

**LUBRICATION SCHEDULE SHOULD  
BE FOLLOWED**

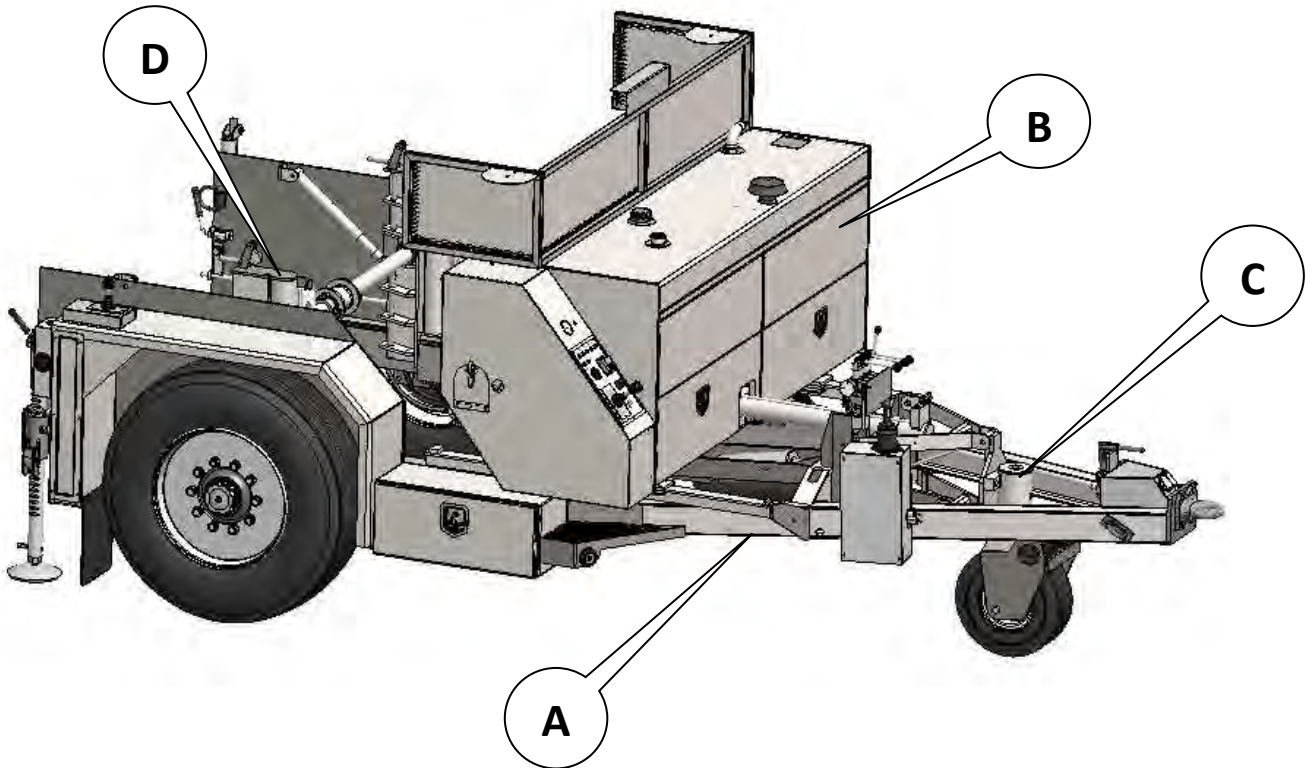



# HYDRA 985

## CONTROLS

The control panel has a variety of gauges and switches that control certain functions during the operation of the HYDRA 985. Here is a description of these controls. (Figure 2)

- A. Hydrastatic Pressure Gauge: This gauge alerts the operator to the system pressure at all times during operation. IT IS NOT A GAUGE TO ILLUSTRATE line pull.
- B. Front / Rear Control: This switch isolates the front and rear controls of the unit during operation.
- C. Ignition Switch
- D. Switch Panel: This panel contains various switches to control functions of the unit. Depending on options installed the location of the switches may vary. They Include: Two speed on the fly shift to Hi or Low speed, marker beacons, level wind, auxiliary air compressor, work lights, auxiliary hydraulic tool circuit, etc.
- E. Joystick: Spring return to Neutral control joystick for operating the Pay out or Take up feature of the puller. Proportional control allows for infinite speeds and pulling force during operation. An "OPERATOR PRESENT" switch may be installed on certain units. This provides security against payout under power. Unit will not pay out until the switch has been pressed and the joystick moved out of the neutral position

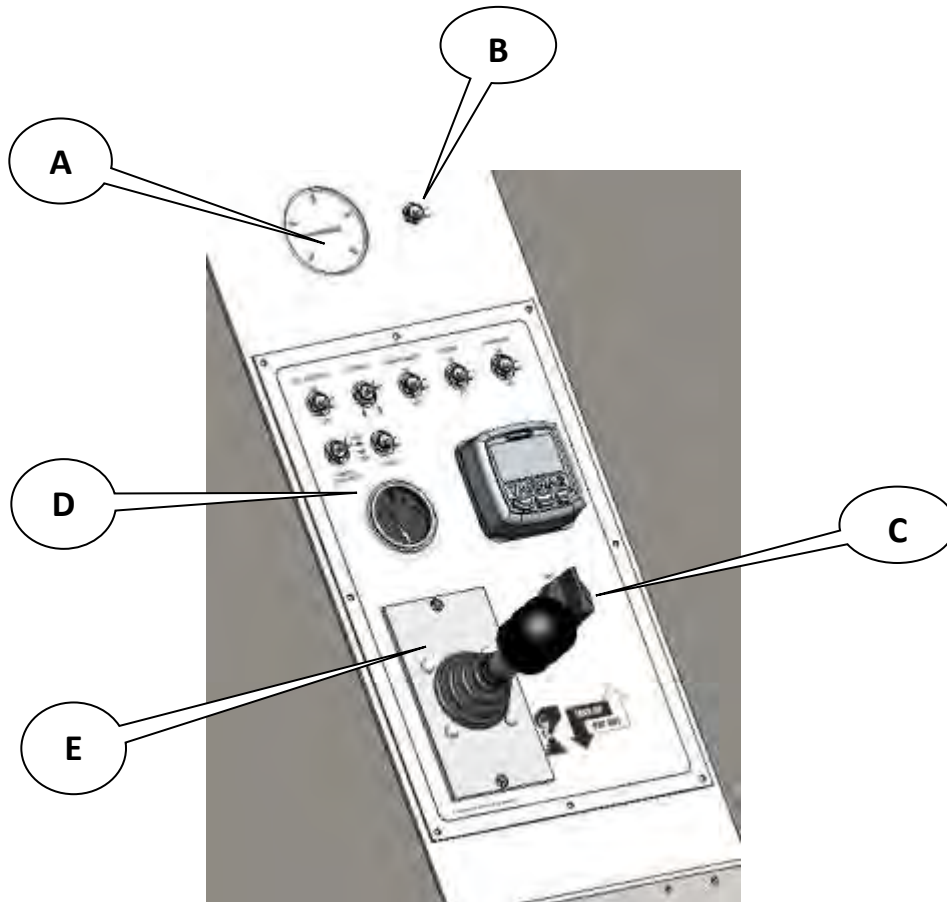

**LOADING INSTRUCTIONS**

# LOADING INSTRUCTIONS

**IMPORTANT:** This unit is designed to load a reel that is setting on the ground. **DO NOT LOAD WITH FORKLIFT** or other device as this causes cable damage and can effect the safe carrying procedures of this unit. **FOLLOW DIRECTIONS.**

## LOADING PROCEDURE

**NOTE:** This dolly will accept reels of 50" to 108" in diameter and 26" minimum to 56" maximum in width.

1. To load, make sure power driving unit is forward as far as possible.
2. Lower mandrel lifts to bottom
3. Pull out mandrel lock rods, remove mandrel and install in reel.
4. If reel bore is over 2-1/2" in diameter, use tapered cones for centering.
5. Always center mandrel in reel so that reel will be centered in dolly.
6. Install lock collar on each side of reel.
7. Place bearing on ends of mandrel.
8. Roll reel into unit or back unit astraddle reel into lifting racks. (Insert mandrel into lowest rack possible.)
9. Put bearing block in place on each end of mandrel to hold bearing.
10. Insert mandrel rack rods through rack and bearing block.
11. Set cylinder locks - one on each side. These are located at rear of fenders. Push handle down to engage.
12. Raise reel until locks snap in place.
13. Lower reel with both valves and hold for 30 seconds to take load off lifting cylinders. Racks should be setting on locks.
14. Adjust each set of drive wheels to center on reel flanges.
15. See instructions for adjusting rollers for proper reel diameter.
16. Move power unit against reel flange before towing this dolly.



## BEFORE TOWING VEHICLE

**NOTE:** With reels that have a single spoke (note drawing following), have spoke in vertical position before moving power unit against flanges.

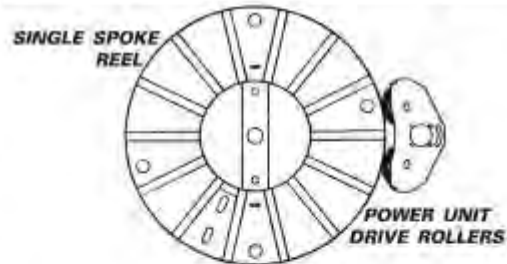

# HYDRA 985

## HYDRAULIC CONTROLS

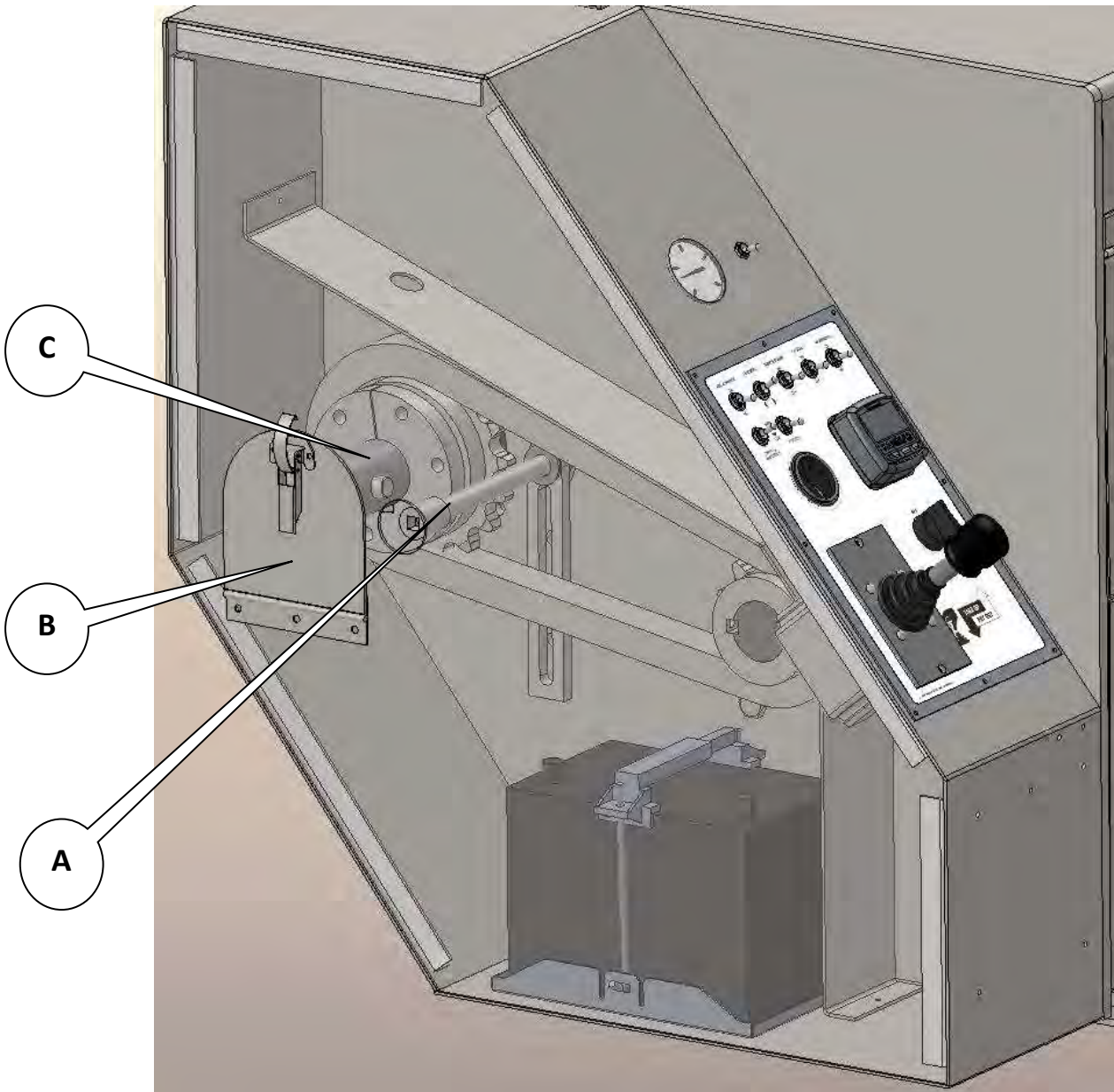

### Power Unit Features

- A- ACME ADJUSTING SCRW
- B - EXTENDED SHAFT GUARD COVER
- C- POWER UNIT DRIVE SHAFT 2 7/16"

## **HYDRA 985**

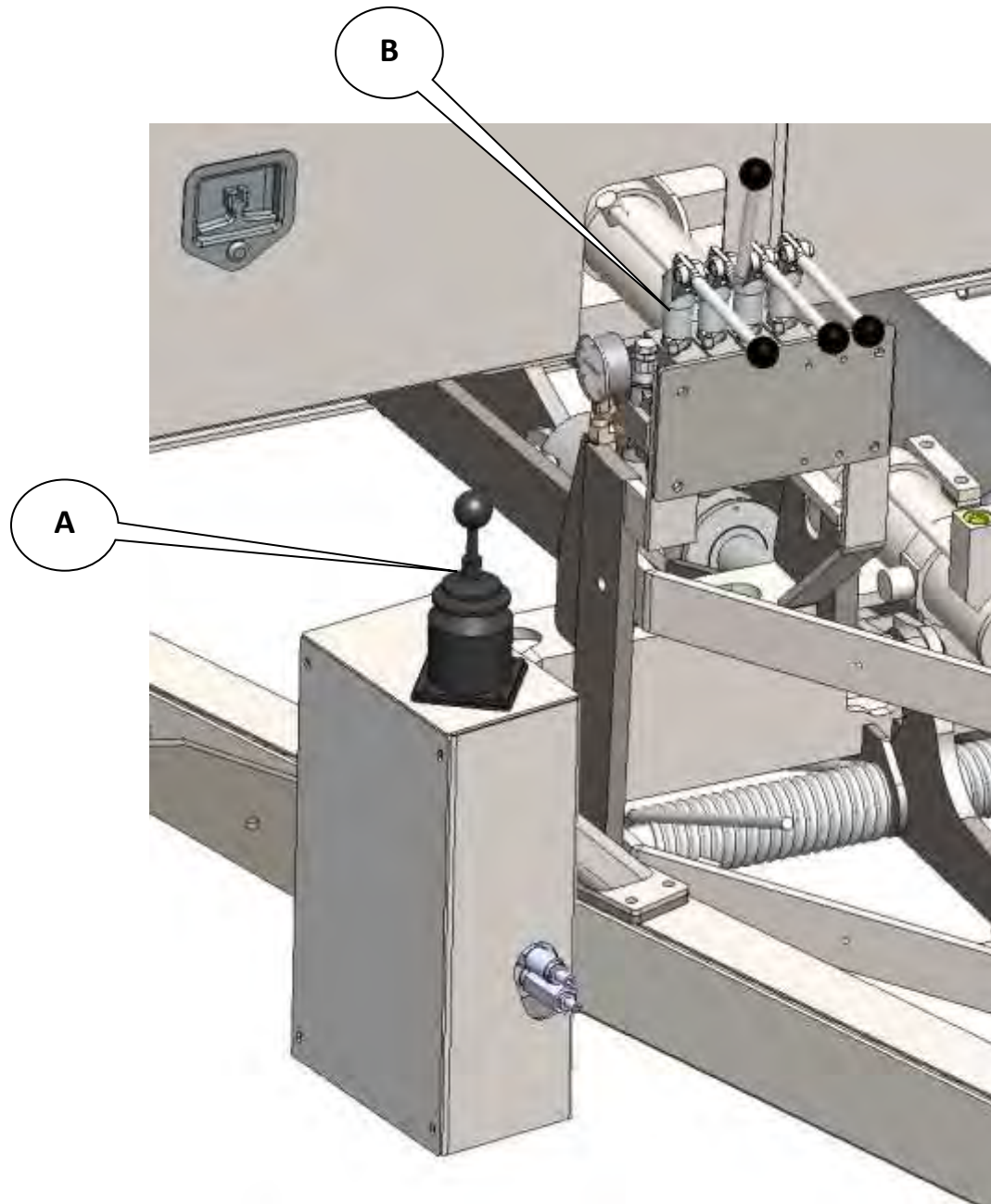

### **FRONT HYDRAULIC CONTROLS**

- A - STEER GO SYSTEM
- B - FRONT HYDRAULIC CONTROLS (DRAWBAR, POWER UNIT, LEFT AND RIGHT MANDREL RACKS)

## HYDRA 985

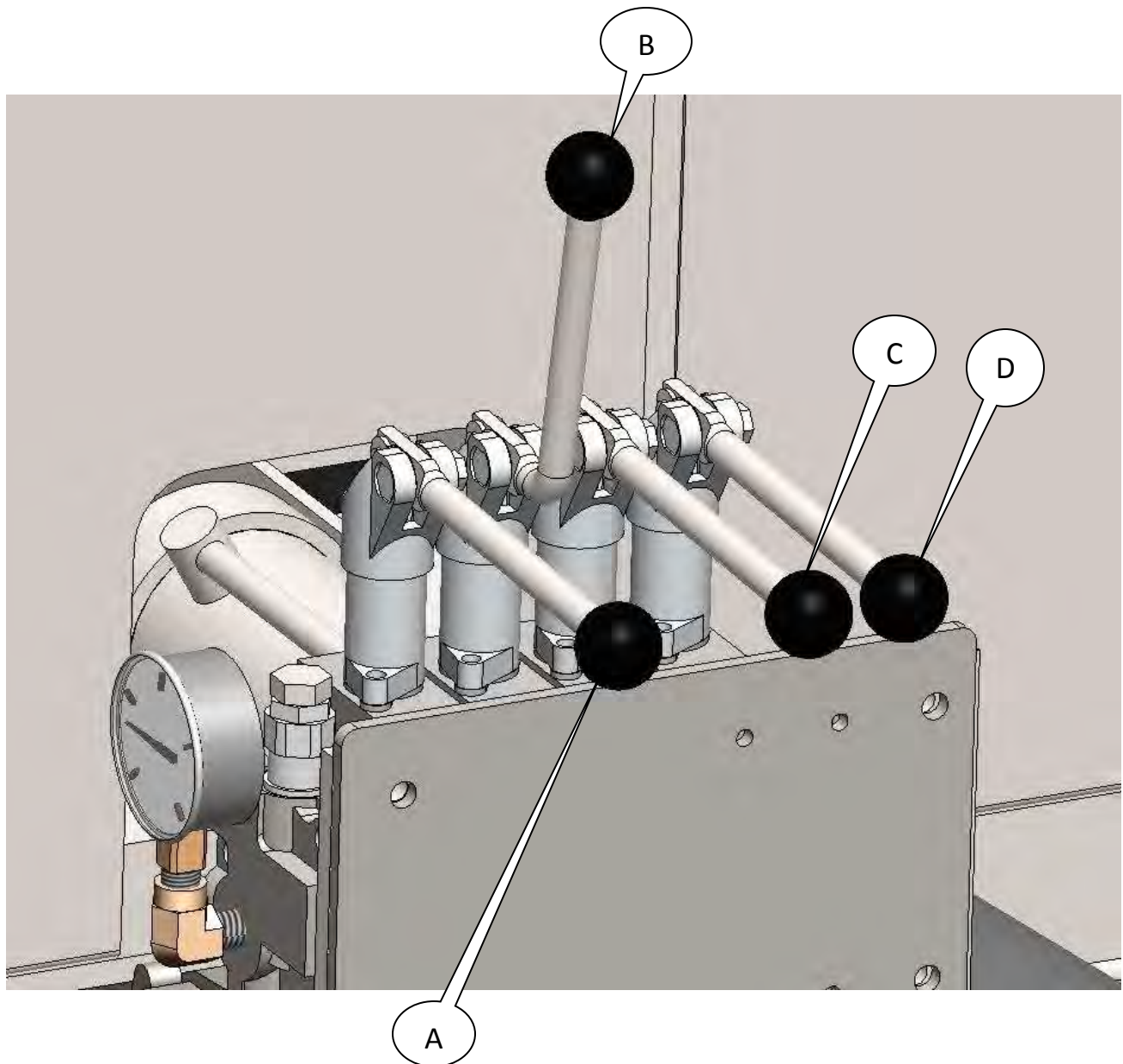

### FRONT CONTROL BANK

- A - DRAWBAR RAISE AND LOWER
- B - POWER UNIT FORWARD AND BACK
- C,D - RIGHT AND LEFT AND RIGHT MANDREL RACK RAISE AND LOWER

# **HYDRA 985**

## **POWER UNIT**

The Power Unit consists of the engine, Hydrostatic Transmission Drive Unit, Drive Rollers, Engine Controls, hydraulic reservoir and auxiliary power shaft. The power unit supplies power for all hydraulic functions and turns the reels to provide cable pulling. Pulling controls are located at the power unit, the rear curb side of the trailer. Electronic controls at the rear of the trailer control the direction of pull for cable take-up or pay-out and control the throttle, level wind, hydraulic tool circuit, and hi and low shift. All primary engine controls are located at the front of the power unit.

## **AUXILIARY POWER SHAFT**

This shaft is located on the side of the power unit and is used for light duty winding operations. Attachments can be added to the shaft. The rotation of the shaft is controlled with the Joystick that controls the take up and pay out functions. When not in use, the shaft should be covered with the cover provided.

## **POWERED IDLER WHEELS AND HYDRAULIC CONTROLS**

The powered idler wheel is located towards the front of the trailer. This wheel is hydraulically raised or lowered and hydraulically powered to provide maneuverability of the trailer when disconnected from the towing vehicle. The wheel is steered by means of a power steering control unit (figure 3). The joystick controls forward and reverses movement as well as left and right direction of the trailer. Refer to the Steer-Go Power Steering section. The hydraulic controls are located between the power unit and the idler wheel at the main drawbar cross member.

The four valves control the following functions:

- Drawbar Height: raise and lower
- Power Unit direction: fore and aft
- Right Mandrel Rack: raise and lower
- Left Mandrel Rack: raise and lower

## **REEL CARRYING RACKS (MANDREL RACKS)**

The reel carrying racks (mandrel racks) are located in the reel carrying area at the rear of the trailer (fig 5A and 5B). These racks have several pockets to allow a variety of reel diameters to be picked from the ground. Follow the LOADING INSTRUCTIONS when loading the reel. The mandrel rack locks are indicated in Fig 5C. Also, Fig 5D shows the rear controls for the power unit and the Jack stands (Fig 5E and 5F)

## **HYDRA 985**

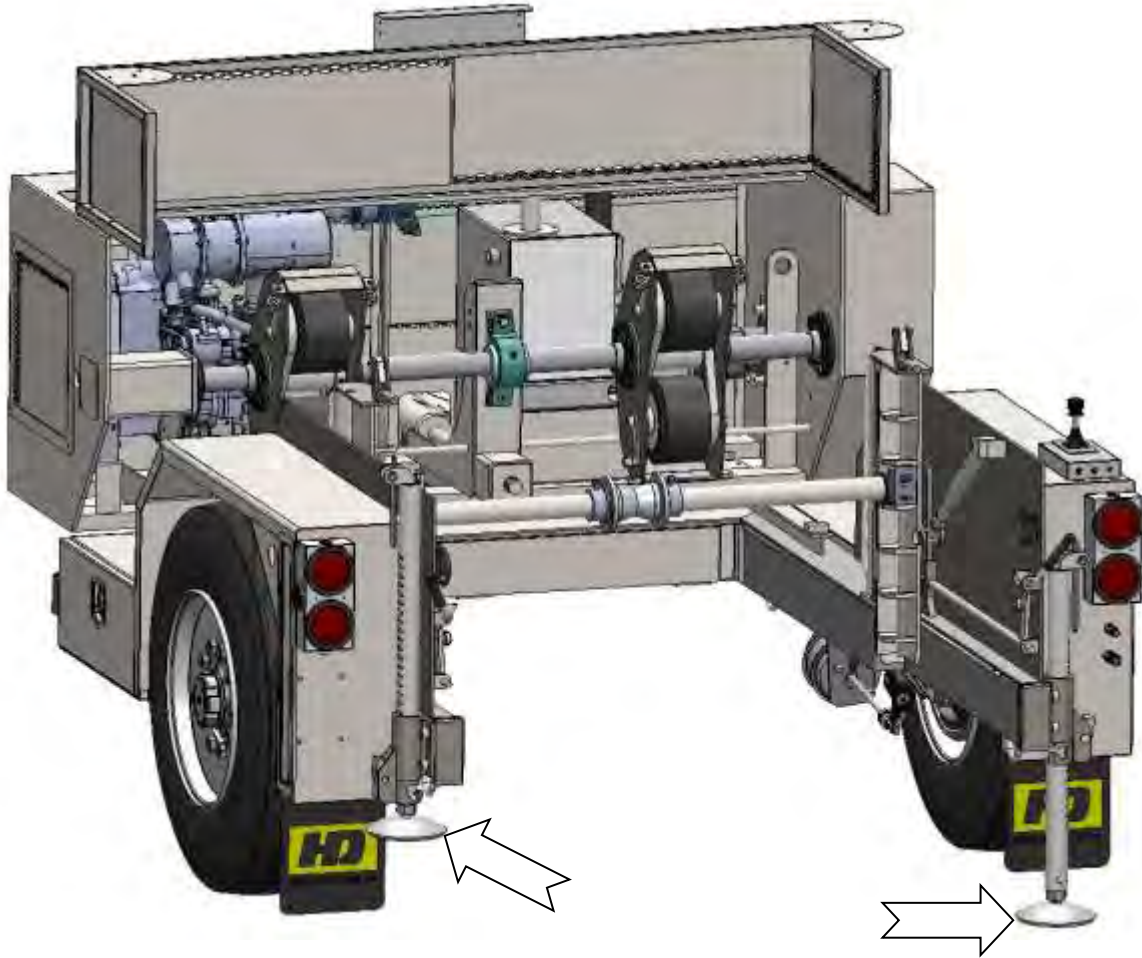

### **JACKSTANDS**

***JACKSTANDS ARE STABILIZING LEGS LOCATED AT THE REAR OF THE TRAILER. THE JACKSTANDS SHOULD BE USED DURING ALL PULLING OPERATIONS***

In Fig 5, the jack stand at the left is shown in the stowed or carried position. The jack stand at the right is shown in the down or pulling position. Each jack stand is positioned by the use of a ratchet locking in the notches. To release the jack stands from the carrying position, lift and rotate out of the carrier. To raise, rotate stand one quarter turn to release the ratchet from the notch and raise the stand to lock into the carrier.

## HYDRA 985

**NOTE: Visual inspection of the drive chain and sprockets is required prior to every use, check chain for wear, slack and damage.**

### MANUEVERING INSTRUCTIONS

One of the main features of the HYDRA 985 is its ability to maneuver under its own power by use of the Powered Idler Wheel and the Steer Go System.

The main intent of the Idler wheel system is to provide for easy maneuverability of the unit around the jobsite, to load and unload the reels, and to aid in the attachment and removal from the tow vehicle. It is NOT designed to move the trailer long distances (example – vault to vault) without the aid of the tow vehicle. It is NOT designed to be used for movement or transportation up or down an incline greater than 2%. Using the Steer Go system in this manner can create extreme stress on the system and could possibly create a failure that could lead to a trailer that can NOT be steered, controlled or stopped.

Any operator MUST be familiar with the control of the trailer when it is being moved with the Idler Wheel System. Familiarize the use of the joystick, engine speed, and the brake controls prior to operating the trailer.

#### USE OF THE STICK WHICH CONTROLS THE IDELR WHEEL MOTOR AS A BRAKE SHOULD BE AVOIDED

### STEER-GO OPERATION

There are two (2) main components in the system.

- A. The Steer-Go Control Box mounted to the right hand (curb) side of the trailer drawbar.
- B. The Rotary Actuator Assembly attached to the Idler Wheel Fork Assembly

Working together, these components allow the operator to easily steer and maneuver the trailer by merely moving the joystick control as desired. The actuator can move the wheel through a 180 degree arc, 90 degrees either side of center.

In the instructions that follow we will often refer to "steering" and "motion" For our purposes, "Steering" will always refer to the action of turning right or left. The word "motion" will always refer to forward or reverse direction of the idler wheel

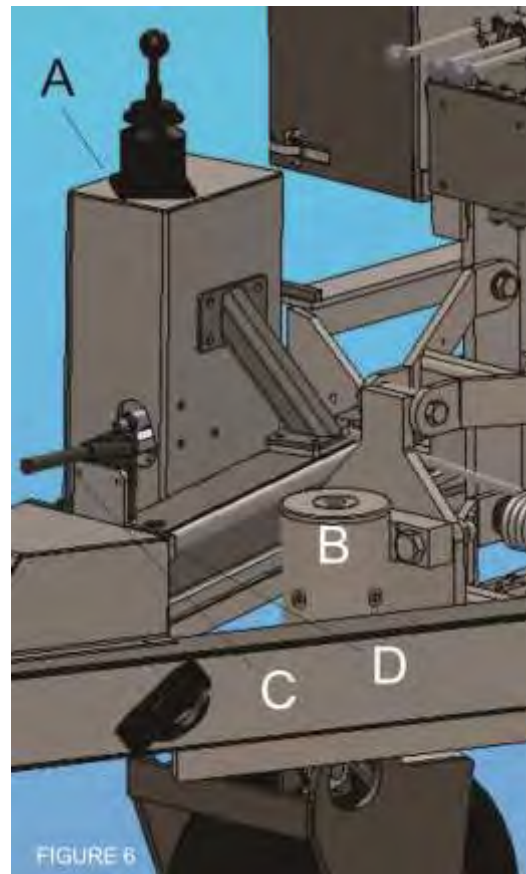



**THE JOYSTICK**

The joystick is a two-axis control that controls both steering and motion of the idler wheel functions. The joystick is either mechanically linked or electronically controlled (depending on options) to hydraulic control valves. Mechanical valves are spring return to neutral. Electronic joysticks are also spring return to neutral. Releasing the joystick will cause all movement to stop.

The linkage system, in the mechanical system, provides quick positive response to the operators action. Because the response is quick, steering right or left is usually accomplished by a series of short, momentary movements of the joystick in the desired left or right direction.

NOTE: Refer to the directional decal (Fig. 7) on the top of the control box prior to operating. Become familiar with the feel of the joystick with the engine running. Note the short movement required to move through the full range of direction

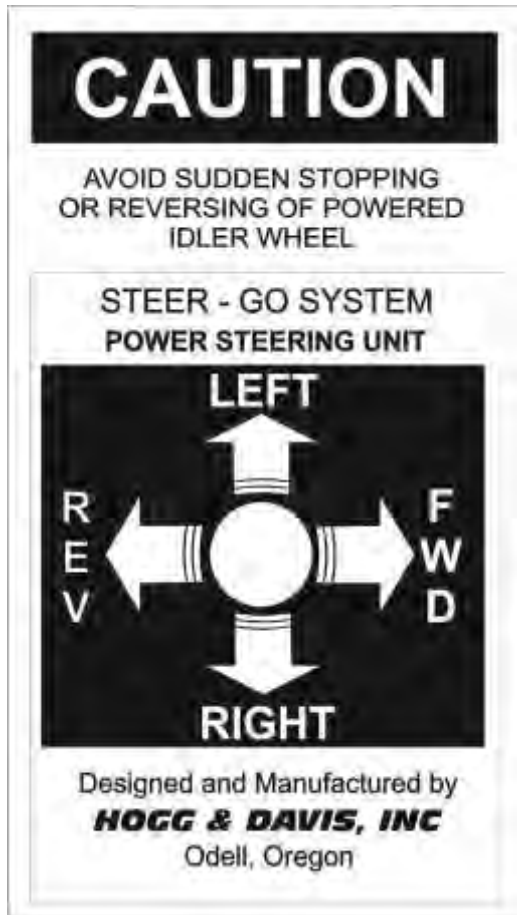

Figure 7

**TO STEER AND MOVE**

CAUTION: Note the direction the idler wheel is pointing before actuating the joystick. The trailer will move in the direction the wheel is pointing

Start the Engine. With the engine running at **IDLE SPEED**, move the joystick to the right or left. (NOTE: *Steering speed is NOT affected by engine RPM*)

Move the joystick to the FWD position. The trailer now travels forward. By holding the joystick in the forward position and moving it to the RIGHT, the trailer will turn RIGHT. Release the turning motion when the wheel has reached the angle of turn you desire. Trailer will continue to turn until you steer LEFT to straighten out the wheel.

To back the trailer, move the joystick to the REV position. When you turn to face the rear of the trailer as you are backing, the steering directions are reversed.

NOTE: *Idler wheel speed is a function of engine RPM. Idle is enough to provide easy, smooth operation. The higher the RPM the faster the unit will move*

# **HYDRA 985**

## **BRAKE CONTROLLERS**

Brake controllers on the HYDRA 985 are what is commonly used in an air brake trailer. Figure 6 shows us the location of the following:

- C: The hand control located on the apex of the trailer
- D: The Push-Pull Switch located at the apex of the trailer

## **ON BOARD AIR COMPRESSOR**

Each air brake unit that is equipped with an engine has an air compressor installed to charge the system while away from a tow vehicle. This compressor is located in the power unit and can be controlled by a switch on the main control panel. It is recommended that the unit engine be started with the switch in the OFF position to allow for maximum battery power for starting. After the engine is running, turn the compressor on to charge the system. Although the compressor has an automatic shut off when it reaches the pre determined pressure in the system, for extended life and better starting power, it is recommended that the compressor be switched OFF after the system pressure has been reached.

## **HYDRA 985**

### **TOOL CIRCUIT (OPTIONAL)**

Some trailers may be equipped with an optional hydraulic tool circuit. The circuit is designed for tools which are used intermittently or for short duration such as a pump or hydraulic cutters. It is NOT designed for uses of long or continuous duration such as hydraulic blowers or generators.

The tool circuit outlets are located in the rear curbside (Fig. 8) fender panels. Two quick disconnect fittings are provided. The tool circuit is actuated by an electric switch located on the main control panel, and the rear fender panel. This system is designed to provide 10 GPM at 2000 psi.

***WARNING: WHEN NOT IN USE, THE SWITCH MUST BE IN THE OFF POSITION. IF THE SWITCH IS LEFT ON, WHEN TOOLS ARE DISCONNECTED, SEVERE BACKPRESSURE WILL OCCUR THAT COULD DAMAGE THE HYDRAULIC SYSTEM.***

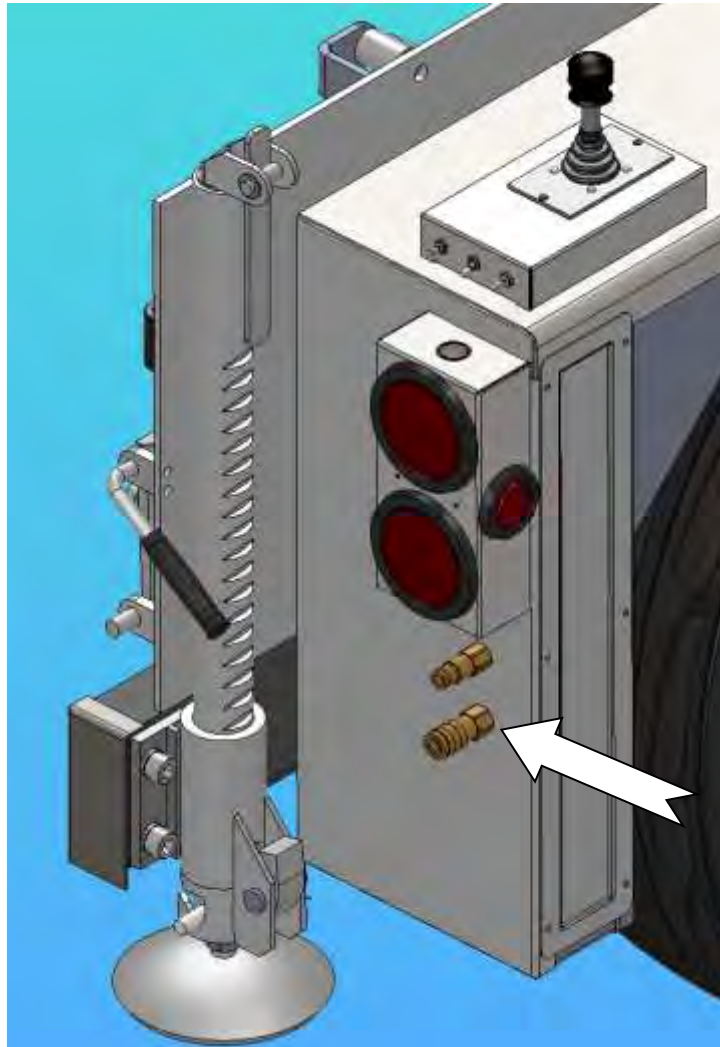

## LEVELWIND OPERATIONS

Some units are equipped with a Level wind System. This system is hydraulically actuated boom style level wind located at the rear of the trailer (Fig. 9)

There are two switch locations to operate the level wind. They are at the main control panel and the rear control panel located at the curbside fender. Each switch is directional in relation with the travel of the level wind boom. That is, if you push the switch to the right, the boom travels right as you view the level wind. If you push the switch left, the boom travels left. The switches are momentary and as you release them, it comes to a neutral position and the boom stops.

The level wind does not operate automatically. The operator must activate the switch each time the rope or wire is to be moved on the reel. The top roller of the boom carriage is made with a swing away mounting to allow for insertion or removal of the line. By removing the pin located in the boom, the upper boom section can be extended or retracted as needed. **DO NOT OPERATE THE LEVELWIND WITHOUT THE PIN INSTALLED IN THE BOOM SECTIONS. THIS MAY CAUSE THE BOOM TO COME OUT OF THE LOWER SECTION DURING OPERATION.**

The level wind is most suitable for overhead pulls. Its use for underground is greatly restricted due to manhole size and amount of pull required. Do not use the level wind as a "breaker bar" for underground pulls.

To load with the level wind installed, pull the left hinge pin and swing the assembly out of the hinge and to the right. After the reel is loaded, swing assembly back into hinge and insert the lock pin.

The lower turnbuckle support is provided to allow for easy movement of the level wind arm during loading and unloading of reels. It may be necessary to adjust this turnbuckle if the unit becomes difficult to swing in and out of the hinge.

The unit can be easily removed from the trailer by disconnecting the hoses and pulling the hinge pins.

**BE SURE TO USE A FORKLIFT OR OVERHEAD CRANE WHEN REMOVING AND INSTALLING THE LEVELWIND ASSEMBLY.**

## HYDRA 985

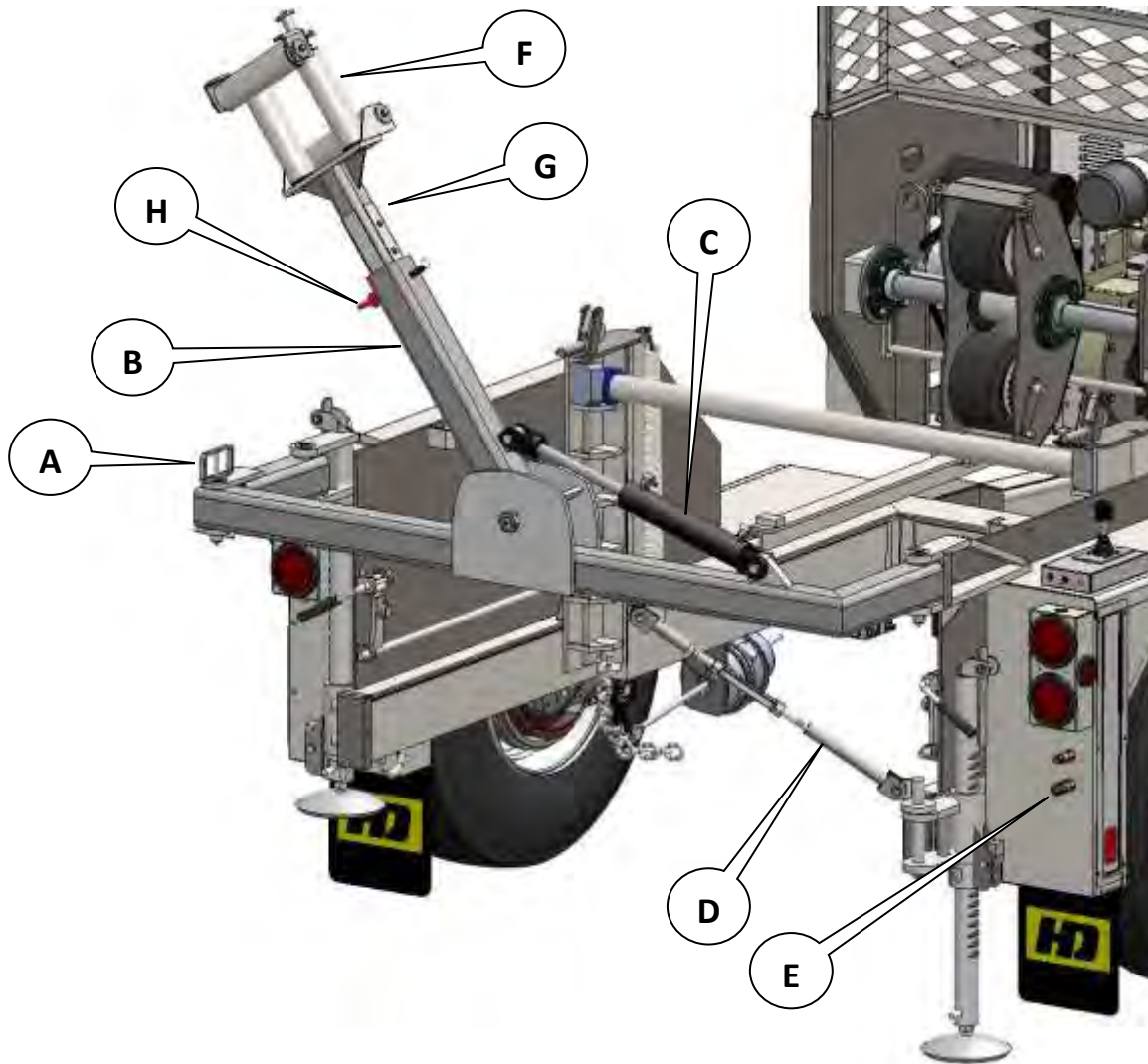

### LEVELWIND COMPONENTS

The following are the main components in the LW Assembly

- A. Hinge Pin
- B. Lower Boom Assembly
- C. Level wind cylinder
- D. Turnbuckle
- E. Hydraulic QD fittings
- F. Carriage Assembly
- G. Upper Boom Assembly
- H. Lock pin for Boom Assemblies



# **HYDRA 985**

## **PULLING PROCEDURES**

Although all jobs will vary, below is a basic description of how to operate the HYDRA 985. Please consult your Employers rules and regulations and always consult and follow guidelines set for by the IEEE.

### **OVERHEAD WIRE**

The following is a basic description of how to set up and pull overhead wire.

1. Set up the dolly with the longest lead possible with the axis of the trailer in line with the pull.
2. Lower the drawbar - set the jack stands - raise the drawbar to put pressure on the legs
3. Chock the wheels
4. Move the drive rollers against the flange of the reel until visible indentations are visible on the drive roller friction material. Apply more pressure to reel flange if drive wheels slip.
5. Select the desired Hi-Lo speed setting
6. Increase engine RPM to 2000
7. Move control lever to take-up position and start pulling.
8. To stop the pull, return the control lever to neutral.

## **DANGER**

**NEVER allow the Power Unit to become disengaged from the reel during an overhead pull. This will cause the reel to spin freely and may drop the rope or conductor. Doing so may cause the pulling line and or wire to drop onto other energized conductors causing serious injury or death**

# **HYDRA 985**

## **UNDERGROUND PULLING**

1. Position the trailer over the manhole (vault opening, etc). The best position for maximum pulling power is to position the reel **DIRECTLY** over the pull.
2. Lower trailer drawbar
3. Set Jack stands
4. Raise trailer drawbar to set pressure on the jack stands. It is not advised to remove the tires from the ground when setting the jack stands. They are there to help stabilize the trailer and spread the load over the entire frame, stub axles and front idler wheel.
5. Chock the tires
6. Set the brakes - Air ABS systems **ONLY**
7. Move the drive rollers against the flange of the reel until visible indentations are visible on the drive roller friction material. Apply more pressure to reel flange if drive wheels slip.
8. Select the desired Hi-Lo speed setting
9. Set the engine RPM to IDLE. Increase engine RPM as needed.

NOTE: Most wreck out jobs can be broken loose with the RPM at idle. If slipping occurs during the pull, gently increase the pressure of the Power Unit against the reel flange.

Level wind on the reel.

After the pull has begun, it may be necessary to keep the pulling rope or wire level on the reel. To do so, stop the pull, lower the drawbar to release pressure on the jack stands, turn the Idler wheel perpendicular to the axis of the trailer and slight change the rear angle of the unit. This slight change will allow the rope to wind itself back towards the other flange. Set the pressure back to the jack stands and continue take-up operation.

# SERVICE





## **HYDRA 985**

### **HYDRA 985 Lubrication**

The following lubrication instructions are offered as "rule of thumb". Precise lubrication instructions will vary with each usage of each unit. **CHECK ALL LUBRICATIONS BEFORE EACH USE**

**ENGINE:** Consult Engine Manual for precise instructions. Unit is delivered by Hogg & Davis, Inc. with 10W40 oil.

**HYDRASTATIC DRIVE SYSTEM:** This Drive System is practically maintenance-free, however the oil should be changed every six months with ISO 46 wt. or its equivalent. There are three oil filters that should be changed also at this time. (Refer to schematic) One of these filters is a high pressure filter and has a restriction gauge on it, this gauge should be checked daily, if it reaches the red line, this filter should be changed immediately.

**WHEEL BEARINGS:** Wheel bearings are of the oil bath style and should be inspected as part of the Drivers Pre-Trip Inspection.

**IDLER WHEEL:** Lubricate every 30 days. Zerk fittings are provided for proper application of lube. Lube all parts, including spindle housing, "A" frame supports, and hydraulic cylinder linkage.

**LIFTING RACKS:** Lubricate every 30 days.. Lube all parts, including rack and attached stabilizer bars. NOTE: If racks do not lower properly, it may be necessary to lift rack entirely off cylinder, and with solvent clean away caked grease and dirt build-up. Wipe thin coat of lube all around cylinder before replacing rack. The holes on the racks are NOT designed for Zerk fittings. They allow air to escape during the lowering process. It may be helpful to spray some light oil into the holes to aid with raising and lowering.

**DRIVER ROLLERS:** Sealed bearings.

**SPROCKET ASSEMBLIES:** Lubricate once each week. Zerk fittings are provided for proper lube application.

**ROLLER CHAIN:** Lubricate once each week. Use regular lube oil to oil all chain, including driver roller chain, main drive chain (oil cup provided), and power idler wheel chain.

**DRIVE SHAFT BEARINGS:** **Lubricate as required.** It is recommended that the track be kept clean of grease and dirt build up, and fresh lube be applied after each cleaning.

**TOOL BOX DOORS:** Lubricate as required. Hinges and locks should be lubricated with oil as needed for easy operation.

NOTE: All lubrication should be performed consistently to insure proper operation and extended life of equipment.

**CAUTION: OILS SHOULD NOT BE MIXED. IF BRAND OR TYPE IS CHANGED, OLD OIL MUST BE DRAINED, ALL FILTERS CHANGED, AND NEW OIL USED THROUGHOUT THE SYSTEM.**

# HYDRA 985

## JACKSTAND INSTALLATION

When installing any model Hogg and Davis Jack stand, the following procedure should be used.

1. Determine if stand is left or right. Hole in side of stand should line up with holding lug on trailer when teeth of stand engage with spring loaded ratchet pawl.
2. Insert stand into sleeve.
3. Install pad with pad bolt. Screw bolt all the way in, leaving just loose enough for pad to swivel.
4. Screw stud into stand until it wedges against the pad bolt. Tighten stud HARD AGAINST pad bolt. This LOCK bolt and eliminates loss of pad from bolt vibrating loose.

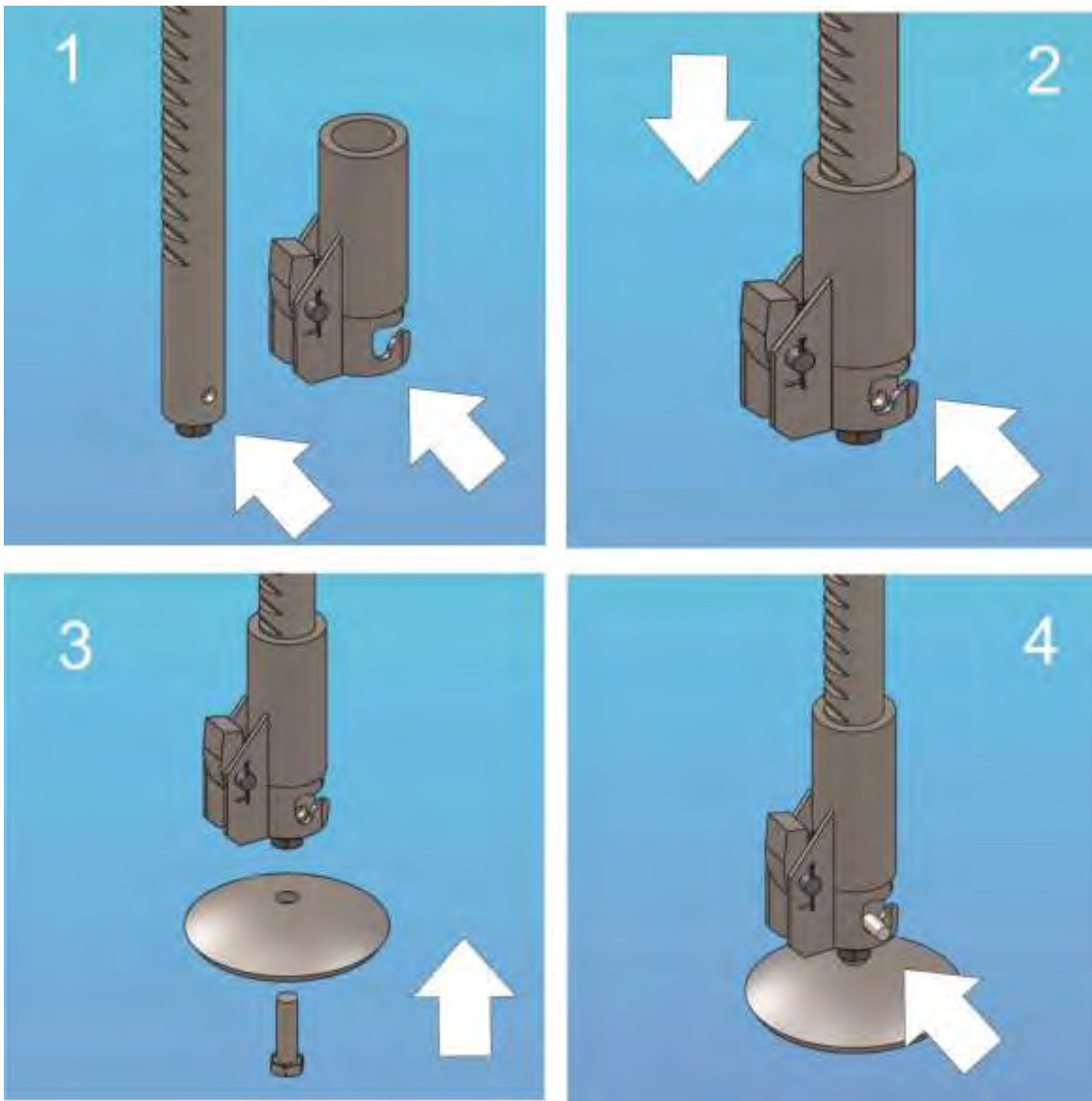

## **HYDRA 985**

### **DRIVE ROLLER MAINTENANCE**

The "heart" of any friction drive cable pulling machine is the rollers that transfers the power to the reel. This is also usually the highest mortality item on these units because they take the full brunt of all the pulling torque. The current production drive roller consists of two (2) pieces; a core and a ring.

The ring consists of a special composition neoprene rubber compound (or optional urethane) molded to a steel ring. The core is made of steel, has bearing seats and a 24-tooth #60 sprocket welded on one end. The core and the ring are machined for press fit tolerance. When repairing roller due to "dead" or torn rubber, the core is pressed out of the old ring and new rings are pressed on.

When replacing rollers, it is advised that they be replaced in horizontal pairs, i.e. both top rollers or both bottom rollers. This is so equal thickness of rubber is applied to each flange of the reel. If replaced in vertical pairs with new, thick rollers in one housing and old compressed rollers in the other housing, the power unit will have the tendency to cock under pressure. This tendency forces the rollers to be cut by the reel flange edges and can greatly reduce the expected life of the roller.

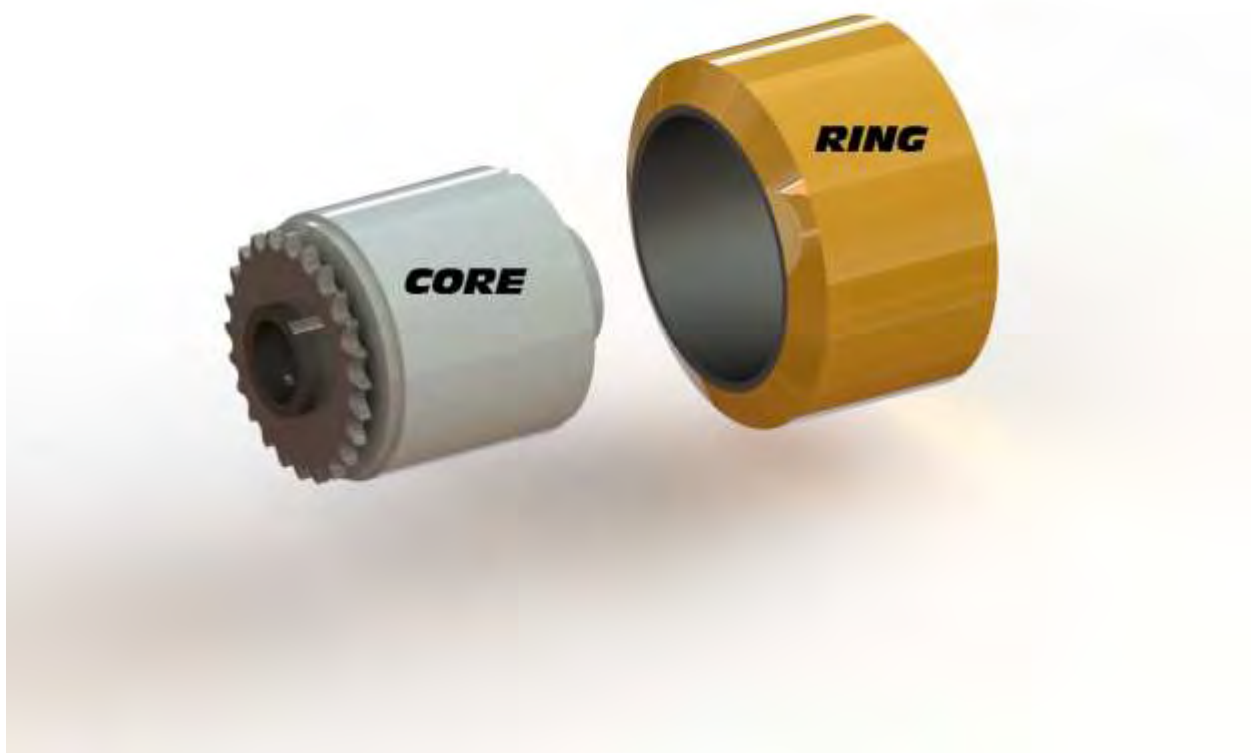

## **HYDRA 985**

### **ACME ADJUSTING SCREW**

Ninety to ninety-five percent of all damage to the acme adjusting screws on the above machine is in the form of bending. Since it is nearly impossible to straighten them to work properly, it is necessary to replace them.

This damage can be prevented by employing one or more of the following simple precautions.

1. Instruct all operators, that after they have adjusted the drive roller housing to its proper position, by use of the screw, to back-off one-half turn. This relieves that binding pressure between the acme nut and the drive roller housing, allowing the housing to "dolly" freely with the shape of the reel flange.
2. Keep the acme screws and drive shaft well greased. This not only allows the drive roller housing to move laterally and "dolly" properly, but will also protect the parts from corrosion and rust.
3. Wipe grease on housing where acme nut makes contact. This will also allow housing to "dolly" easier without binding.
4. Be sure acme screw brackets are adjusted to maintain a level setting throughout the drive roller housings

### **DRAWDAR INSPECTION**

1. Regularly inspect the drawbar for wear and damage. If wear exceeds 1/8", replace the drawbar.
2. Check all drawbar mounting fasteners for proper torque.
3. Do not modify or add to the product.
4. Do not weld on this product without written permission from the factory.
5. Be sure the drawbar size is compatible with the coupling device on the tow vehicle.
6. Do not damage the coupling components. Be particularly careful during coupling and uncoupling.
7. Inspect the coupling device on the tow vehicle for proper locking prior to use.
8. Consult OSHA and DOT regulations and AMERICAN TRUCKING ASSOCIATION GUIDELINES FOR COMPLETE OPERATING PROCEDURES.

# HYDRA 985

## MANDREL RACK STABILIZER INSTALLATION

The mandrel rack stabilizers are very critical to the proper operation of your trailer. One stabilizer is attached to each mandrel rack. This stabilizer keeps the racks rigid and takes all the strain put against the racks when pressure is applied by the power unit against the reel. Without the stabilizers, the power unit could apply enough pressure to bend or break the lifting cylinders upon which the mandrel racks ride. Therefore, it is important that the stabilizers be properly installed and maintained.

When it becomes necessary to replace a stabilizer due to damage or loss, the new stabilizer will be sent with the stop nut loose on the male rod portion of the stabilizer (Fig. 1).

The stabilizer should be bolted in position between the mandrel rack and the anchor bracket on the fender panel. The rack should then be raised to its locked position and settled on the lock. The stabilizer should now be at a right angle to the rack and parallel to the top of the fender panel. The stop nut should be screwed on the male shaft until it sits against the female portion of the stabilizer. (Fig.2).

Loctite® can be used to properly set the stop nut. Proper installation will assure protection against damage to lifting cylinders and stability for rack and reel mandrel.

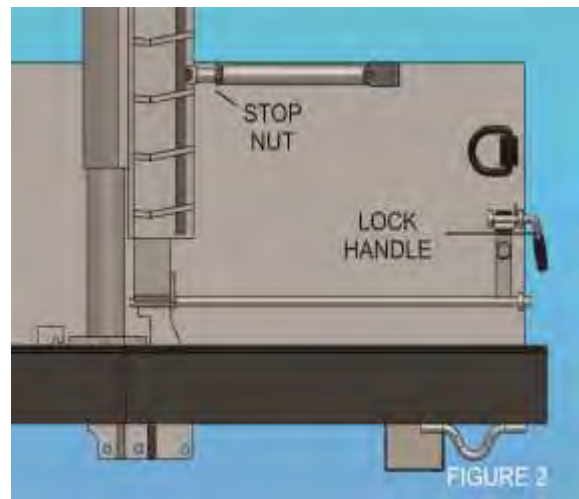
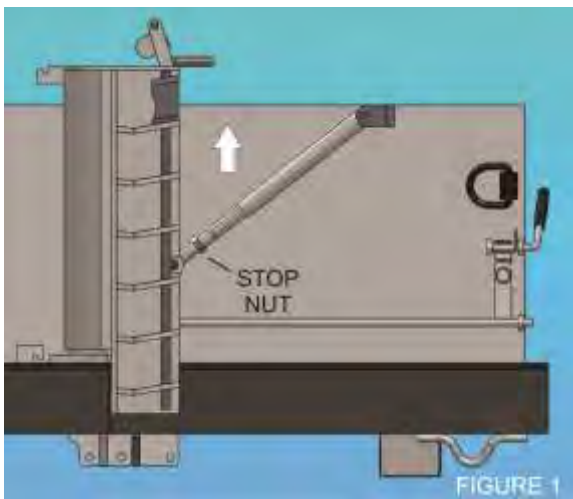

## Section 2

# YANMAR WARRANTIES

---

	Page
YANMAR Limited Warranty .....	2-3
What is Covered by this Warranty? .....	2-3
How Long is the Warranty Period? .....	2-3
What the Engine Owner must Do: .....	2-3
To Locate an Authorized YANMAR Industrial Engine Dealer or Distributor: .....	2-4
What YANMAR will Do: .....	2-4
What is not Covered by this Warranty? .....	2-4
Warranty Limitations: .....	2-5
Warranty Modifications: .....	2-5
Questions: .....	2-5
Emission System Warranty .....	2-6
YANMAR Co., Ltd. Limited Emission Control System Warranty - USA Only .....	2-6
Your Warranty Rights and Obligations: .....	2-6
Manufacturer's Warranty Period:.....	2-6
Warranty Coverage: .....	2-7
Warranted Parts: .....	2-7
Exclusions: .....	2-8
Owner's Warranty Responsibilities:.....	2-8

## YANMAR LIMITED WARRANTY

### What is Covered by this Warranty?

YANMAR warrants to the original retail purchaser that a new YANMAR TNV series industrial engine will be free from defects in material and/or workmanship for the duration of the warranty period.

*Note: YANMAR engines may be equipped with external components including, but not limited to: wiring harnesses, electrical devices, control panels, radiators, air filters, fuel filters, and/or exhaust systems that are supplied and/or installed by manufacturers other than YANMAR. For warranty information on such external components, please contact the machine or component manufacturer directly or see your authorized YANMAR dealer or distributor.*

This warranty is provided in lieu of all other warranties, express or implied. YANMAR specifically disclaims any implied warranties of merchantability or fitness for a particular purpose, except where such disclaimer is prohibited by law. If such disclaimer is prohibited by law, then implied warranties shall be limited in duration to the life of the express warranty.

### How Long is the Warranty Period?

The YANMAR standard limited warranty period runs for a period of **twenty-four (24) months or two-thousand (2000) engine operation hours**, whichever occurs first. An extended limited warranty of thirty-six (36) months or three thousand (3000) engine operating hours, whichever occurs first, is provided for these specific parts only: the cylinder block, cylinder head, crankshaft forging, connecting rods, flywheel, flywheel housing, camshaft, timing gear, and gear case. The warranty period for both the standard limited warranty and the extended limited warranty (by duration or operation hours) begins on the date of delivery to the original retail purchaser and is valid only until the applicable warranted duration has passed or the operation hours are exceeded, whichever comes first.

### What the Engine Owner must Do:

If you believe your YANMAR engine has experienced a failure due to a defect in material and/or workmanship, you must contact an authorized YANMAR industrial engine dealer or distributor within thirty (30) days of discovering the failure. You must provide proof of ownership of the engine, proof of the date of the engine purchase and delivery, and documentation of the engine operation hours. Acceptable forms of proof of delivery date include, but are not limited to: the original warranty registration or sales receipts or other documents maintained in the ordinary course of business by YANMAR dealers and/or distributors, indicating the date of delivery of the YANMAR product to the original retail purchaser. This information is necessary to establish whether the YANMAR product is still within the warranty period. Thus, YANMAR strongly recommends you register your engine as soon as possible after purchase in order to facilitate any future warranty matters.

You are responsible for the transportation of the engine to and from the repair location as designated by YANMAR.

***YANMAR limited warranty - continued*****To Locate an Authorized YANMAR Industrial Engine Dealer or Distributor:**

You can locate your nearest authorized YANMAR industrial engine dealer or distributor by visiting the YANMAR Co., Ltd. website at:

<http://www.yanmar.co.jp> (The Japanese language page will be displayed.) For English language “click” on “English Page.”)

- “Click” on “Network” in the website heading to view the “Yanmar Worldwide Network.”
- Choose and “Click” on the desired product group.
- “Click” on the Icon closest to your region.
- “Click” on the desired country or associate company to locate your nearest authorized YANMAR industrial engine dealer or distributor.
- You may also contact YANMAR by clicking on “Inquiry” in the website heading and typing in your question or comment.

**What YANMAR will Do:**

YANMAR warrants to the original retail purchaser of a new YANMAR engine that YANMAR will make such repairs and/or replacements at YANMAR’s option, of any part(s) of the YANMAR product covered by this warranty found to be defective in material and/or workmanship. Such repairs and/or replacements will be made at a location designated by YANMAR at no cost to the purchaser for parts or labor.

**What is not Covered by this Warranty?**

This warranty does not cover parts affected by or damaged by any reason other than defective materials or workmanship including, but not limited to, accident, misuse, abuse, “Acts of God,” neglect, improper installation, improper maintenance, improper storage, the use of unsuitable attachments or parts, the use of contaminated fuels, the use of fuels, oils, lubricants, or fluids other than those recommended in your YANMAR Operation Manual, unauthorized alterations or modifications, ordinary wear and tear, and rust or corrosion. This warranty does not cover the cost of parts and/or labor required to perform normal/scheduled maintenance on your YANMAR engine. This warranty does not cover consumable parts such as, but not limited to, filters, belts, hoses, fuel injector nozzles, lubricants and cleaning fluids. This warranty does not cover the cost of shipping the product to or from the warranty repair facility.



*YANMAR limited warranty - continued***Warranty Limitations:**

The foregoing is YANMAR's only obligation to you and your exclusive remedy for breach of warranty. Failure to follow the requirements for submitting a claim under this warranty may result in a waiver of all claims for damages and other relief. **In no event shall YANMAR or any authorized industrial engine dealer or distributor be liable for incidental, special or consequential damages.** Such consequential damages may include, but not be limited to, loss of revenue, loan payments, cost of rental of substitute equipment, insurance coverage, storage, lodging, transportation, fuel, mileage, and telephone costs. The limitations in this warranty apply regardless of whether your claims are based on breach of contract, tort (including negligence and strict liability) or any other theory. Any action arising hereunder must be brought within one (1) year after the cause of action accrues or it shall be barred. Some states and countries do not allow certain limitations on warranties or for breach of warranties. **This warranty gives you specific legal rights, and you may also have other rights which vary from state to state and country to country.** Limitations set forth in this paragraph shall not apply to the extent that they are prohibited by law.

**Warranty Modifications:**

Except as modified in writing and signed by the parties, this warranty is and shall remain the complete and exclusive agreement between the parties with respect to warranties, superseding all prior agreements, written and oral, and all other communications between the parties relating to warranties. **No person or entity is authorized to give any other warranty or to assume any other obligation on behalf of YANMAR, either orally or in writing.**

**Questions:**

If you have any questions or concerns regarding this warranty, please call or write to the nearest authorized YANMAR industrial engine dealer or distributor or other authorized facility.

**EMISSION SYSTEM WARRANTY**

**YANMAR CO., LTD. LIMITED EMISSION CONTROL SYSTEM WARRANTY - USA ONLY**

**Your Warranty Rights and Obligations:**

■ **California**

The California Air Resources Board (CARB), the Environmental Protection Agency (EPA) and YANMAR Co., Ltd. hereafter referred to as YANMAR, are pleased to explain the **emission control system warranty** on your industrial compression-ignition engine. In California, model year 2000 or later off-road compression-ignition engines must be designed, built and equipped to meet the state’s stringent anti-smog standards. In all states, 1998 and later non-road compression-ignition engines must be designed, built and equipped to meet the United States EPA emissions standards. YANMAR warrants the emission control system on your engine for the periods of time listed below provided there has been no abuse, neglect or improper maintenance of your engine.

Your emission control system may include parts such as the fuel injection system, Electronic Control Unit, Exhaust Gas Recirculation (EGR) system, after treatment system (DPF) and the air induction system. Also included may be hoses, belts, connectors and other emission-related assemblies.

Where a warrantable condition exists, YANMAR will repair your non-road compression-ignition engine at no charge to you including diagnosis, parts and labor.

**Manufacturer’s Warranty Period:**

The model year 1998 or later certified and labeled non-road compression-ignition engines are warranted for the periods listed below. If any emission-related part on your engine is found to be defective during the applicable warranty period, the part will be replaced by YANMAR.

If your engine is certified as	And its maximum power is	And its rated speed is	Then its warranty period is
Variable speed or constant speed	kW < 19	Any speed	1,500 hours or two (2) years whichever comes first. In the absence of a device to measure the hours of use, the engine has a warranty period of two (2) years.
Constant speed	19 ≤ kW < 37	3,000 rpm or higher	1,500 hours or two (2) years whichever comes first. In the absence of a device to measure the hours of use, the engine has a warranty period of two (2) years.
Constant speed	19 ≤ kW < 37	Less than 3,000 rpm	3,000 hours or five (5) years whichever comes first. In the absence of a device to measure the hours of use, the engine has a warranty period of five (5) years.
Variable speed	19 ≤ kW < 37	Any speed	3,000 hours or five (5) years whichever comes first. In the absence of a device to measure the hours of use, the engine has a warranty period of five (5) years.
Variable speed or constant speed	kW ≥ 37	Any speed	3,000 hours or five (5) years whichever comes first. In the absence of a device to measure the hours of use, the engine has a warranty period of five (5) years.

**Limited emission control system warranty - USA only - continued****Warranty Coverage:**

This warranty is transferable to each subsequent purchaser for the duration of the warranty period. Repair or replacement of any warranted part will be performed at an authorized YANMAR industrial engine dealer or distributor.

Warranted parts not scheduled for replacement as required maintenance in the operation manual shall be warranted for the warranty period. Warranted parts scheduled for replacement as required maintenance in the operation manual are warranted for the period of time prior to the first scheduled replacement. Any part repaired or replaced under warranty shall be warranted for the remaining warranty period.

During the warranty period, YANMAR is liable for damages to other engine components caused by the failure of any warranted part during the warranty period.

Any replacement part which is functionally identical to the original equipment part in all respects may be used in the maintenance or repair of your engine, and shall not reduce YANMAR's warranty obligations. Add-on or modified parts that are not exempted may not be used. The use of any non-exempted add-on or modified parts shall be grounds for disallowing a warranty.

**Warranted Parts:**

This warranty covers engine components that are a part of the emission control system of the engine as delivered by YANMAR to the original retail purchaser. Such components may include the following:

- Fuel injection system
- Electronic control system
- Cold start enrichment system
- Intake manifold
- Turbocharger systems
- Exhaust manifold
- EGR system
- Positive crankcase ventilation system
- After treatment system (Diesel Particulate Filter)
- Hoses, belts, connectors and assemblies associated with emission control systems

Since emissions-related parts may vary slightly between models, certain models may not contain all of these parts and other models may contain the functional equivalents.

***Limited emission control system warranty - USA only - continued*****Exclusions:**

Failures other than those arising from defects in material and/or workmanship are not covered by this warranty. The warranty does not extend to the following: malfunctions caused by abuse, misuse, improper adjustment, modification, alteration, tampering, disconnection, improper or inadequate maintenance or use of non-recommended fuels and lubricating oils; accident-caused damage, and replacement of expendable items made in connection with scheduled maintenance. YANMAR disclaims any responsibility for incidental or consequential damages such as loss of time, inconvenience, loss of use of equipment/engine or commercial loss.

**Owner's Warranty Responsibilities:**

**As the engine owner, you are responsible for the performance of the required maintenance listed in your owner's manual.** YANMAR recommends that you retain all documentation, including receipts, covering maintenance on your non-road compression-ignition engine, but YANMAR cannot deny warranty solely for the lack of receipts, or for your failure to ensure the performance of all scheduled maintenance.

YANMAR may deny your warranty coverage of your non-road compression-ignition engine if a part has failed due to abuse, neglect, improper maintenance or unapproved modifications.

Your engine is designed to operate on diesel fuel only. Use of any other fuel may result in your engine no longer operating in compliance with applicable emissions requirements.

You are responsible for initiating the warranty process. You must present your engine to a YANMAR dealer as soon as a problem exists. The warranty repairs should be completed by the dealer as expeditiously as possible. If you have any questions regarding your warranty rights and responsibilities, or would like information on the nearest YANMAR dealer or authorized service center, you should contact YANMAR America Corporation.

Website: [www.yanmar.com](http://www.yanmar.com)

E-mail: [CS\\_support@yanmar.com](mailto:CS_support@yanmar.com)

Toll free telephone number: 1-800-872-2867, 1-855-416-7091

SPN	FMI	TEXT TRANSLATION
28	3	% Accelerator Position #3 (Throttle 2) Voltage Above Normal or Shorted to High Source H
28	4	Percent Accelerator Position #3 (Throttle 2) Voltage Below Normal or Shorted to Low Source
29	3	Percent Accelerator Position #2 (Throttle 1) Voltage Above Normal or Shorted to High Source
29	4	Percent Accelerator Position #2 (Throttle 1) Voltage Below Normal or Shorted to Low Source
91	3	Accelerator Pedal Position (Multi-State Throttle) Voltage Above Normal, or Shorted to High Source
91	4	Accelerator Pedal Position (Multi-State Throttle) Voltage Below Normal or Shorted to Low Source
91	9	Accelerator Pedal Position A valid throttle message is not being received or is late
91	14	Accelerator Pedal Position Throttle signal voltage is or has been out of range
94	1	Fuel Delivery Pressure Pressure Very low
94	3	Fuel Delivery Pressure Fuel Rail Pressure Voltage out of range high
94	4	Fuel Delivery Pressure Fuel Rail Pressure Voltage out of range low
94	10	Fuel Delivery Pressure Pressure dropping too fast
94	13	Fuel Delivery Pressure Out of calibration
94	16	Fuel Delivery Pressure High fuel pressure
94	17	Fuel Delivery Pressure No rail fuel pressure
94	18	Fuel Delivery Pressure Low fuel pressure
97	0	Water In Fuel Indicator Water In Fuel Detected
97	3	Water In Fuel Indicator Water In Fuel Voltage out of range high
97	4	Water In Fuel Indicator Water In Fuel Voltage out of range low
97	16	Water In Fuel Indicator Water In Fuel Detected
97	31	Water In Fuel Indicator Water In Fuel Detected
100	1	Engine Oil Pressure Low oil pressure
100	3	Engine Oil Pressure Voltage Above Normal or Shorted to High Source
100	4	Engine Oil Pressure Voltage Below Normal or Shorted to Low Source
100	16	Engine Oil Pressure Oil pressure reading incorrect
100	18	Engine Oil Pressure Low oil pressure
105	0	Intake Manifold 1 Temperature High manifold air temperature
105	3	Intake Manifold 1 Temperature Voltage Above Normal or Shorted to High Source
105	4	Intake Manifold 1 Temperature Voltage Below Normal or Shorted to Low Source
105	16	Intake Manifold 1 Temperature High manifold air temperature
107	0	Air Filter Differential Pressure Plugged air filter condition detected
107	31	Air Filter Differential Pressure Plugged air filter condition detected
110	0	Engine Coolant Temperature High coolant temperature
110	3	Engine Coolant Temperature Voltage Above Normal or Shorted to High Source
110	4	Engine Coolant Temperature Voltage Below Normal or Shorted to Low Source
110	15	Engine Coolant Temperature High coolant temperature
110	16	Engine Coolant Temperature High coolant temperature
111	1	Coolant Level Low coolant level
158	2	Keyswitch Intermittent
158	17	Keyswitch Circuit problem
174	0	Fuel Temperature High fuel temperature
174	3	Fuel Temperature Voltage Above Normal or Shorted to High Source
174	4	Fuel Temperature Voltage Below Normal or Shorted to Low Source
174	15	Fuel Temperature High fuel temperature
174	16	Fuel Temperature High fuel temperature
174	31	Fuel Temperature Voltage out of range
189	31	Rated Engine Speed Speed Derate Condition Exists due to fault
190	0	Engine Speed Engine overspeed
190	2	Engine Speed Data Erratic, Intermittent or Incorrect
190	3	Engine Speed Voltage Above Normal or Shorted to High Source
190	4	Engine Speed Voltage Below Normal or Shorted to Low Source
190	5	Engine Speed Circuit is open
190	16	Engine Speed Engine overspeed

SPN	FMI	TEXT TRANSLATION
611	3	Injector Wiring Shorted to battery
611	4	Injector Wiring Shorted to ground
620	3	Sensor Supply Voltage 1 (+5V DC) Voltage Above Normal or Shorted to High Source
620	4	Sensor Supply Voltage 1 (+5V DC) Voltage Below Normal or Shorted to Low Source
627	1	Power Supply Low voltage to injectors
627	4	Power Supply Power interruption
629	13	Reprogram Controller ECU problem
629	19	ECU to Pump Communications Error ECU not receiving messages from Pump
632	2	Fuel Shutoff Valve Fuel Shutoff Error Detected
632	5	Fuel Shutoff Valve Fuel Shutoff Non-Functional
632	11	Fuel Shutoff Valve Fuel Shutoff Solenoid circuit is open or shorted
636	2	Engine Position Sensor Timing signal error
636	8	Engine Position Sensor Timing signal error
636	10	Engine Position Sensor Timing signal error
637	2	Timing (Crank) Sensor Timing signal error
637	7	Timing (Crank) Sensor Timing signal error
637	8	Timing (Crank) Sensor Timing signal error
637	10	Timing (Crank) Sensor Timing signal error
639	13	CAN Bus The CAN bus failure
651	5	Injector Cylinder #1 The current to the injector is less than expected
651	6	Injector Cylinder #1 The current to the injector increases too rapidly
651	7	Injector Cylinder #1 The injector fuel flow is lower than expected
652	5	Injector Cylinder #2 The current to the injector is less than expected
652	6	Injector Cylinder #2 The current to the injector increases too rapidly
652	7	Injector Cylinder #2 The injector fuel flow is lower than expected
653	5	Injector Cylinder #3 The current to the injector is less than expected
653	6	Injector Cylinder #3 The current to the injector increases too rapidly
653	7	Injector Cylinder #3 The injector fuel flow is lower than expected
654	5	Injector Cylinder #4 The current to the injector is less than expected
654	6	Injector Cylinder #4 The current to the injector increases too rapidly
654	7	Injector Cylinder #4 The injector fuel flow is lower than expected
655	5	Injector Cylinder #5 The current to the injector is less than expected
655	6	Injector Cylinder #5 The current to the injector increases too rapidly
655	7	Injector Cylinder #5 The injector fuel flow is lower than expected
656	5	Injector Cylinder #6 The current to the injector is less than expected
656	6	Injector Cylinder #6 The current to the injector increases too rapidly
656	7	Injector Cylinder #6 The injector fuel flow is lower than expected
729	3	Inlet Air Heater Driver #1 Inlet air heater stuck on
729	5	Inlet Air Heater Driver #1 Inlet air heater will not turn on
833	2	Rack Position Sensor Error
833	3	Rack Position Sensor Rack Position Voltage above normal
833	4	Rack Position Sensor Rack Position Voltage below normal
834	2	Rack Actuator Rack Error
834	3	Rack Actuator Rack Actuator Circuit voltage above normal
834	5	Rack Actuator Rack Actuator Circuit open
834	6	Rack Actuator Rack Actuator Circuit grounded
834	7	Rack Actuator Rack Position Error
970	2	Auxiliary Engine Shutdown Switch External Engine Shutdown Switch intermittent
970	11	External Engine Protection Shutdown External Engine Protection Shutdown active
970	31	Auxiliary Engine Shutdown Switch External Engine Protection Shutdown active
971	31	Engine Derate Switch External Derate input has been activated
1041	2	Start Signal Indicator Start Signal Missing
1041	3	Start Signal Indicator Start Signal Always Active

SPN	FMI	TEXT TRANSLATION
1076	0	Fuel Injection Pump Fuel Control Valve Error
1076	1	Fuel Injection Pump Fuel Control Valve Error
1076	2	Fuel Injection Pump Fuel Control Valve Error
1076	3	Fuel Injection Pump Fuel Control Valve Error
1076	5	Fuel Injection Pump Fuel Control Valve Error
1076	6	Fuel Injection Pump Fuel Control Valve Error
1076	7	Fuel Injection Pump Fuel Control Valve Error
1076	10	Fuel Injection Pump Fuel Control Valve Error
1076	13	Fuel Injection Pump Fuel Control Valve Error
1077	7	Fuel Injection Pump Controller
1077	11	Fuel Injection Pump Controller
1077	12	Fuel Injection Pump Controller
1077	19	Fuel Injection Pump Controller
1077	31	Fuel Injection Pump Controller Power derated
1078	7	Fuel Injection Pump Speed/Position Sensor Error
1078	11	Fuel Injection Pump Speed/Position Sensor Error
1078	31	Fuel Injection Pump Speed/Position Sensor VP44 Unable to Achieve Desired Timing
1079	3	Sensor Supply Voltage 1 (+5V DC) Voltage Above Normal or Shorted to High Source
1079	4	Sensor Supply Voltage 1 (+5V DC) Voltage Below Normal or Shorted to Low Source
1080	3	Sensor Supply Voltage 2 (+5V DC) Voltage Above Normal or Shorted to High Source
1080	4	Sensor Supply Voltage 2 (+5V DC) Voltage Below Normal or Shorted to Low Source
1109	31	Engine Protection System Approaching Shutdown Approaching Shutdown
1110	31	Engine Protection System Engine has been shutdown
1347	5	Fuel Pump Assembly #1 The circuit is open, shorted to ground, or overloaded
1347	7	Fuel Pump Assembly #1 Rail pressure control mismatch
1347	10	Fuel Pump Assembly #1 Low fuel flow
1348	5	Fuel Pump Assembly #2 The circuit is open, shorted to ground, or overloaded
1348	10	Fuel Pump Assembly #2 Low fuel flow
1485	2	ECU Main Relay Pump power relay fault
1569	31	Engine Protection Torque Derate Fuel derate limit condition exists
2000	6	Fuel Injection Pump Fuel Control Valve Error
2000	13	Security Violation The proper controller has not been installed

## 2G-ECO Governor Controller DTC Table

Remark	DTC			Description	J1939 Lamp Status			
	J1939 Format				MIL	RSL	AWL	PL
	SPN (Hex)	SPN (DEC)	FMI					
	4BA	1210	4	Engine Fuel Rack Position Sensor : Shorted to low source			X	
			3	Engine Fuel Rack Position Sensor : Shorted to high source		X (Engine drive)	X (E-ECU start)	
	5B	91	4	Accelerator Pedal Position Sensor "A" : Shorted to low source			X	
			3	Accelerator Pedal Position Sensor "A" : Shorted to high source			X	
			2	Accelerator Pedal Position Sensor "A" : Intermittent fault				
			1	Accelerator Pedal Position Sensor "A" : Below normal operational range (SAE J1843)				X
			0	Accelerator Pedal Position Sensor "A" : Above normal operational range (SAE J1843)				X
	1D	29	15	Accelerator Pedal Position Sensor "A" : Not available (SAE J1843)			X	
			4	Accelerator Pedal Position Sensor "B" : Shorted to low source			X	
			3	Accelerator Pedal Position Sensor "B" : Shorted to high source			X	
			2	Accelerator Pedal Position Sensor "B" : Intermittent fault				
			1	Accelerator Pedal Position Sensor "B" : Below normal operational range (SAE J1843)				X
	6C	108	0	Accelerator Pedal Position Sensor "B" : Above normal operational range (SAE J1843)			X	
			8	Accelerator Pedal Position Sensor "B" : Communication fault			X	
			15	Accelerator Pedal Position Sensor "B" : Not available (SAE J1843)			X	
	470	1136	4	Barometric Pressure Sensor : Shorted to low source	X			
			3	Barometric Pressure Sensor : Shorted to high source	X			
			2	Barometric Pressure Sensor : Intermittent fault				
			0	Barometric Pressure Sensor : Intermittent fault				
	6E	110	4	E-ECU Internal Temperature Sensor : Shorted to low source			X	
			3	E-ECU Internal Temperature Sensor : Shorted to high source			X	
			2	E-ECU Internal Temperature Sensor : Intermittent fault				
			0	E-ECU Internal Temperature : Too High				X
	437	1079	4	Engine Coolant Temperature Sensor : Shorted to low source			X	
			3	Engine Coolant Temperature Sensor : Shorted to high source (FUEL INJ PUMP SPEED SENSOR)				X
			2	Engine Coolant Temperature Sensor : Intermittent fault				
	9E	158	0	Engine Coolant Temperature : Too High				X
			1	System Voltage : Too Low				X
	436	1078	4	System Voltage : Too High				X
	436	1078	4	Engine Fuel Injection Pump Speed Sensor : Shorted to low source		X (Both)	X (Ether)	
*	7F8A2	522402	4	Auxiliary Speed Sensor : Shorted to low source		X		
*	7F801	522241	4	Engine Fuel Rack Actuator Relay : Circuit fault A		X		
			3	Engine Fuel Rack Actuator Relay : Circuit fault B		X		
			7	(Reserved)				
			2	Engine Fuel Rack Actuator Relay : Intermittent fault				
*	7F803	522243	4	Air Heater Relay : Circuit fault A	X			
			3	Air Heater Relay : Circuit fault B	X			
			2	Air Heater Relay : Intermittent fault				
*	7F802	522242	4	Cold Start Device : Circuit fault A	X			
			3	Cold Start Device : Circuit fault B	X			
			2	Cold Start Device : Intermittent fault				
*	7F80B	522251	4	EGR Stepping Motor "A" : Circuit fault A	X			
			3	EGR Stepping Motor "A" : Circuit fault B	X			
*	7F80C	522252	4	EGR Stepping Motor "B" : Circuit fault A	X			
			3	EGR Stepping Motor "B" : Circuit fault B	X			
*	7F80D	522253	4	EGR Stepping Motor "C" : Circuit fault A	X			
			3	EGR Stepping Motor "C" : Circuit fault B	X			
*	7F80E	522254	4	EGR Stepping Motor "D" : Circuit fault A	X			
			3	EGR Stepping Motor "D" : Circuit fault B	X			
	64	100	4	Oil Pressure Switch : Shorted to low source			X	
			1	Oil Pressure : Too Low				X
	A7	167	4	Battery Charge Switch : Shorted to low source			X	
			1	Charge warning				X
*	7F84A	522314	0	Engine Coolant Temperature : Abnormal temperature				X
*	7F853	522323	0	Air Cleaner : Mechanical Malfunction				X
*	7F859	522329	0	Oily Water Separator : Mechanical Malfunction				X
	BE	190	0	Engine speed : Over speed Condition		X		
	27E	638	4	Engine Fuel Rack Actuator : Shorted to low source		X		
			3	Engine Fuel Rack Actuator : Shorted to high source		X		
			7	Engine Fuel Rack Actuator : Mechanical Malfunction		X		
			2	Engine : Malfunction		X		
	27F	639	12	High Speed CAN Communication : Communication fault			X	
	276	630	2	E-ECU internal fault : EEPROM Check Sum Error (Data Set 2)		X		
			12	E-ECU internal fault : EEPROM ReadWrite fault			X	
	274	628	12	E-ECU internal fault : FlashROM Check Sum Error (Main Software)		X		
			2	E-ECU internal fault : FlashROM Check Sum Error (Data Set 1)		X		
			2	E-ECU internal fault : FlashROM Check Sum Error (Data Set 2)		X		
	5CD	1485	4	E-ECU Main Relay : Shorted to low source			X	
*	7F9E7	522727	12	E-ECU internal fault : Sub-CPU Error A			X	
			12	E-ECU internal fault : Sub-CPU Error B			X	
			12	E-ECU internal fault : Sub-CPU Error C			X	
*	7F9E8	522728	12	E-ECU internal fault : Engine Map Data Version Error		X		
*	7F9EA	522730	12	Immobilizer : CAN Communication fault			X	
			8	Immobilizer : Pulse Communication fault			X	
	4B2	1202	2	Immobilizer : System fault			X	

Remark : Yanmar original DTC



# **HYDRA 985**

## **Parts Manual**



The information, specifications, and illustrations in this manual are on the basis of information available at the time it was written. The specifications, torque values, pressures of operation, measurements, adjustments, illustrations, and other items can change at any time. These changes can affect the service of the given product.

For the complete and most current information, contact:

Hogg & Davis, Inc  
P.O. Box 405 / 3800 Eagle Loop  
Odell, OR 97044-0405  
541-354-1001  
541-354-1080 Fax  
[www.hoggdavis.com](http://www.hoggdavis.com)



*"Rugged Dependability."*

© COPYRIGHT 2016 HOGG & DAVIS, INC



**ver. 2.0**

## **TABLE OF CONTENTS**

1. Isometric View
  2. Unit Dimensions
  3. Power Unit with brake (Front view)
  4. Power Unit with brake (Rear view)
  5. Power Unit brake
  6. Brake Manifold
  7. Power Unit with brake drive assembly
  8. Power Unit without brake (Front view)
  9. Power Unit without brake (Rear view)
  10. Power Unit without brake Tier 4 (Front View)
  11. Power Unit without brake Tier 4 (Rear View)
  12. Power Unit without brake drive assembly
  13. Drive Roller Assembly (for all power units)
  14. Drive Rollers
  15. Engine/ Pump Assembly
  16. Engine/ Pump Assembly Tier 4
  17. Control Panel 1
  18. Control Panel 2
  19. Control Panel 3 Tier 4
  20. Rear Controls
  21. HYPS1 Steer-Go/ Idler Wheel
  22. HYPS1 Steer-Go/ Idler Wheel Bill of Materials
  23. HYPS2 Steer-Go/ Idler Wheel Controls
  24. HYBAC Air Compressor
  25. HYBA Air Brakes
  26. HYBA Air Brakes Bill of Materials
  27. Mandrel Racks
  28. HYLW Post Levelwind
  29. HYLW Post Levelwind Bill of Materials
  30. HYLW2 Screw Levelwind
  31. HYLW2 Screw Levelwind Bill of Materials
  32. HYLW3 Screw Levelwind
  33. HYLW3 Screw Levelwind Bill of Materials
- Cont.....

# **HYDRA 985**

- 34. HYLW3 Screw Levelwind
- 35. HYLW3 Screw Levelwind
- 36. Manual Jackstands
- 37. Hydraulic Outriggers
- 38. Hydraulic Outriggers Bill of Materials
- 39. Tank Assembly for Power Unit Without Brake
- 40.** Tank Assembly for Power Unit With Brake
- 41.** Hi-Vis Screen for power Unit Without Brake
- 42.** Hi-Vis Screen for power Unit With Brake
- 43.** HYHC Hydraulic Capstan
- 44.** Trailer Electrical Connections
- 45.** Incandescent Trailer Lights
- 46.** LED Trailer Lights
- 47.** Valve Banks
- 48.** Trailer Specs.
- 51.** Electrical Schematics
- 64.** Wheel Torque Specs.
- 66.** Decals/ Decal Locations

***If items look different from the parts breakdown please call for assistance. (541)354-1001***



*"Rugged Dependability."*

© COPYRIGHT 2016 HOGG & DAVIS, INC



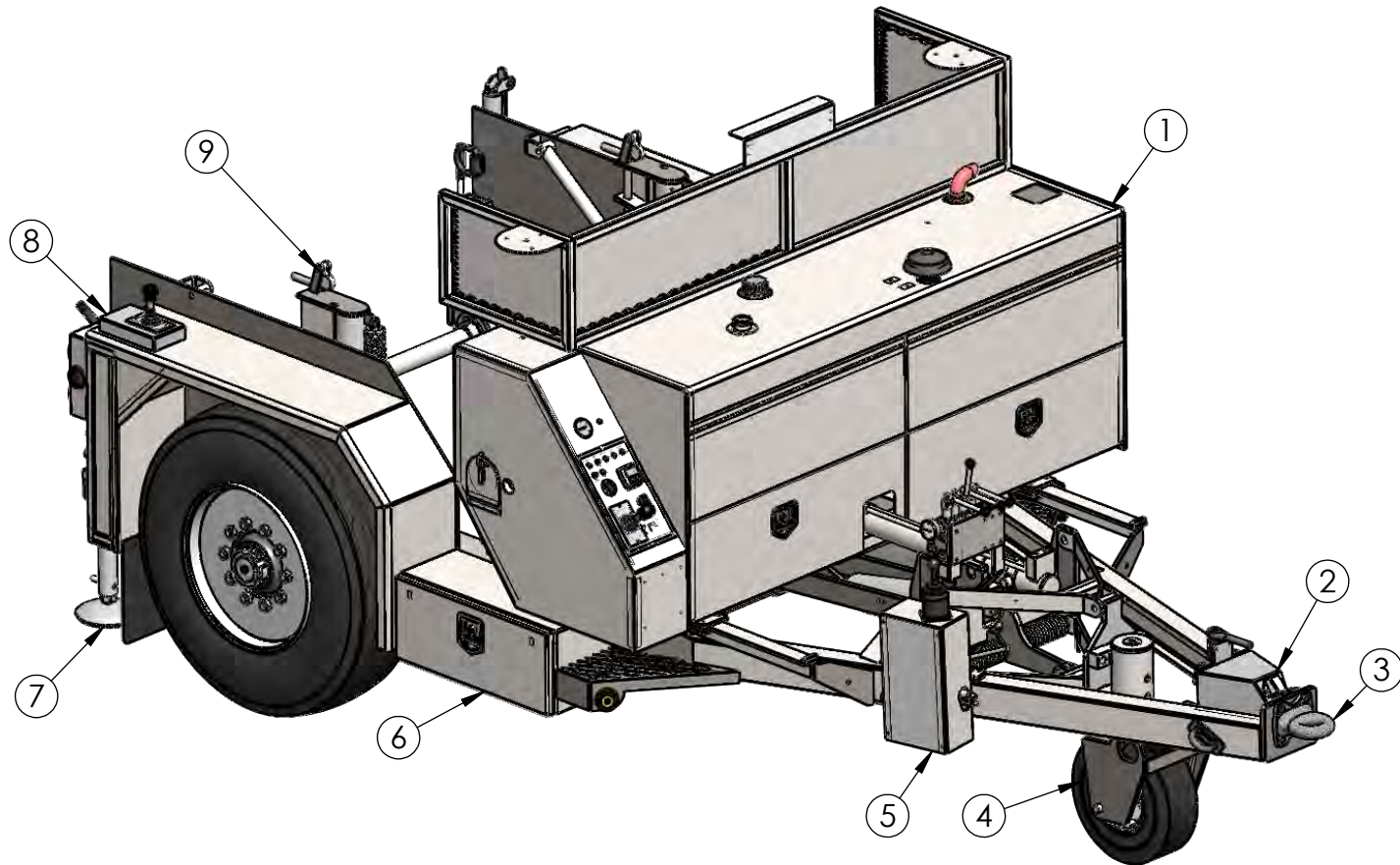

ITEM NO.	PART NUMBER	DESCRIPTION	QTY.
1	Hydra 985 Power Unit T4f	See Power unit sheet	1
2	HYEC7	7 wire electrical hood	1
3	E04017	Eye, Pintle	1
4	HYP51	Power Steering, Drive Assembly	1
5	HYP52	Power Steering, Control Assembly	1
6	D05150	Toolbox Door	2
7	Manual Jackstands	See Jackstand sheet	1
8	Rear controls	Standard Rear Control Package	1
9	Mandrel Racks	See Mandrel rack sheet	1

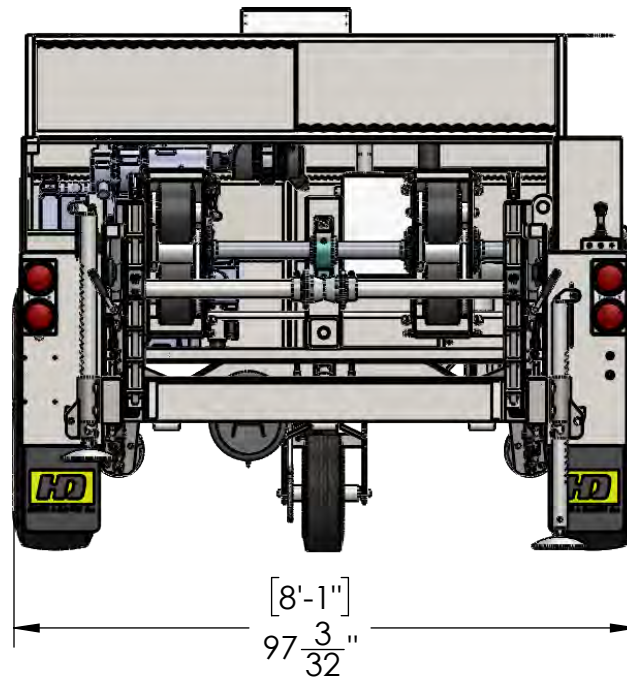
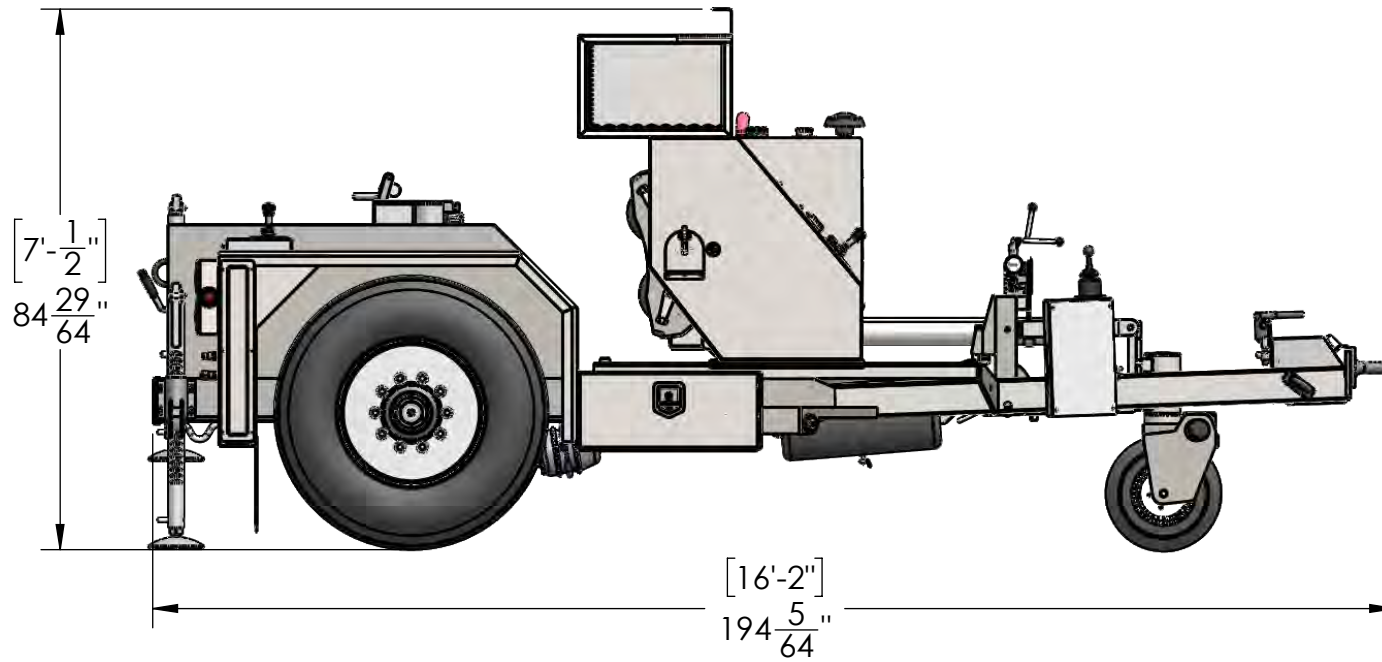

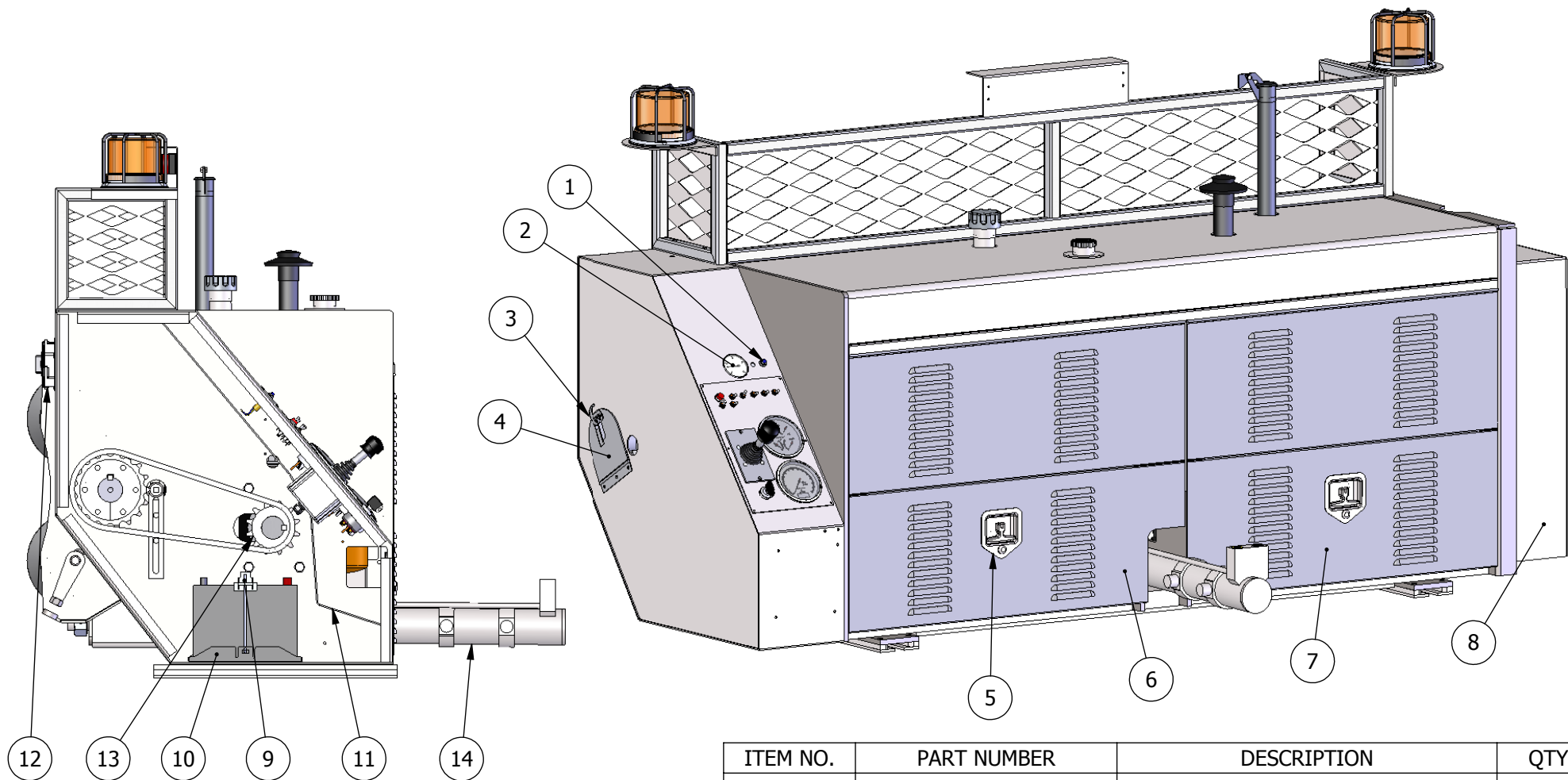

ITEM NO.	PART NUMBER	DESCRIPTION	QTY.
1	L04200	PreHeat Light	1
2	G02075	Gauge, 5000 PSI	1
3	L01020	Latch, Over center	1
4	C29083	Cover, Driveshaft Capstan	1
5	L08025	Lock, T-Handle	2
6	D05202	RH PU/B Door	1
7	D05203	LH PU/B Door	1
8	C29200	Radiator Cover	1
9	R19025	Battery hold down	1
10	H10060	Tray, battery	1
11	G09203	Guard, Chain	1
12	H10020	Registration Holder	1
13	S29933	Sprocket	1
14	C32050	Cylinder, Power Unit	1

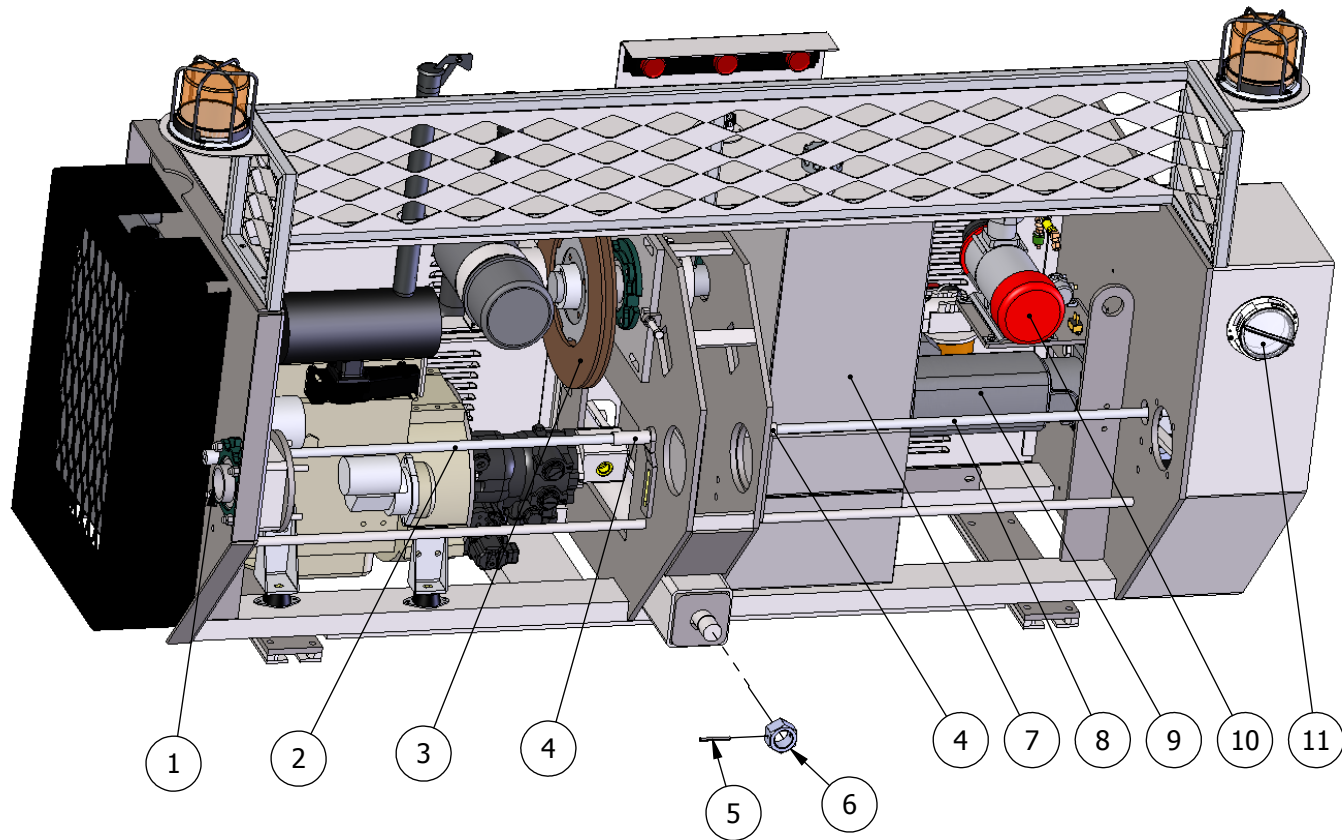

ITEM NO.	PART NUMBER	DESCRIPTION	QTY.
1	B07198	Bearing, SC Pilot Flange 2-7/16"	1
2	S04015	Screw, Acme	1
3	Brake assembly	See Brake Assy Sheet	1
4	B15043	Bracket, Acme Screw Adjust Long	2
5	P06193	Pin, Roll 1/4 x 2-1/2	1
6	N04130	Nut 1 1/2-12 Z	1
7	Tanks	Tank Assembly	1
8	S04153	Screw, Acme Long	1
9	M08010	Hydra Motor	1
10	HYBAC	Air Brake Compressor Option	1
11	H10020	Registration Holder	1

**HYDRA 985**  
**Power Unit With Brake**



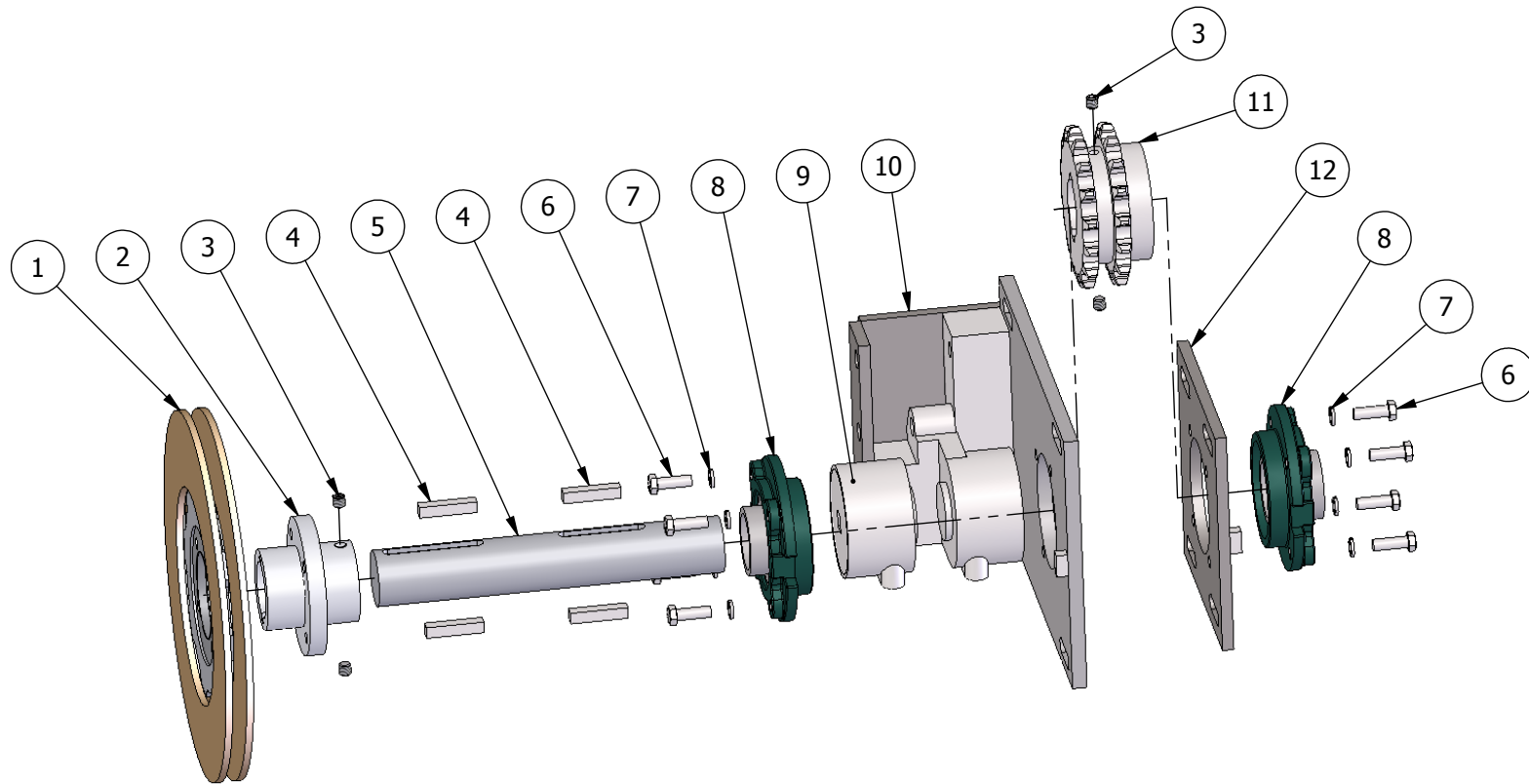

ITEM NO.	PART NUMBER	DESCRIPTION	QTY.
1	D02020	Disc, Vented Brake	1
2	H09104	Hub, Brake Disc	1
3	S04032	Screw, Set 1/2-13x1/2	4
4	K01010	Key, 1/2 x 1/2 x 2-1/2	4
5	S43012	Shaft	1
6	B11368	Bolt Hx head 1/2-13x1-1/2	8
7	W01565	Washer, Split Lock 1/2"	8
8	B07198	Bearing, SC Pilot Flange 2-7/16"	2
9	C04024	Caliper, Fail Safe	1
10	B15112	Brake Mount	1
11	S29004	Sprocket D100B16	1
12	P09200	Bearing Mount Plate	1



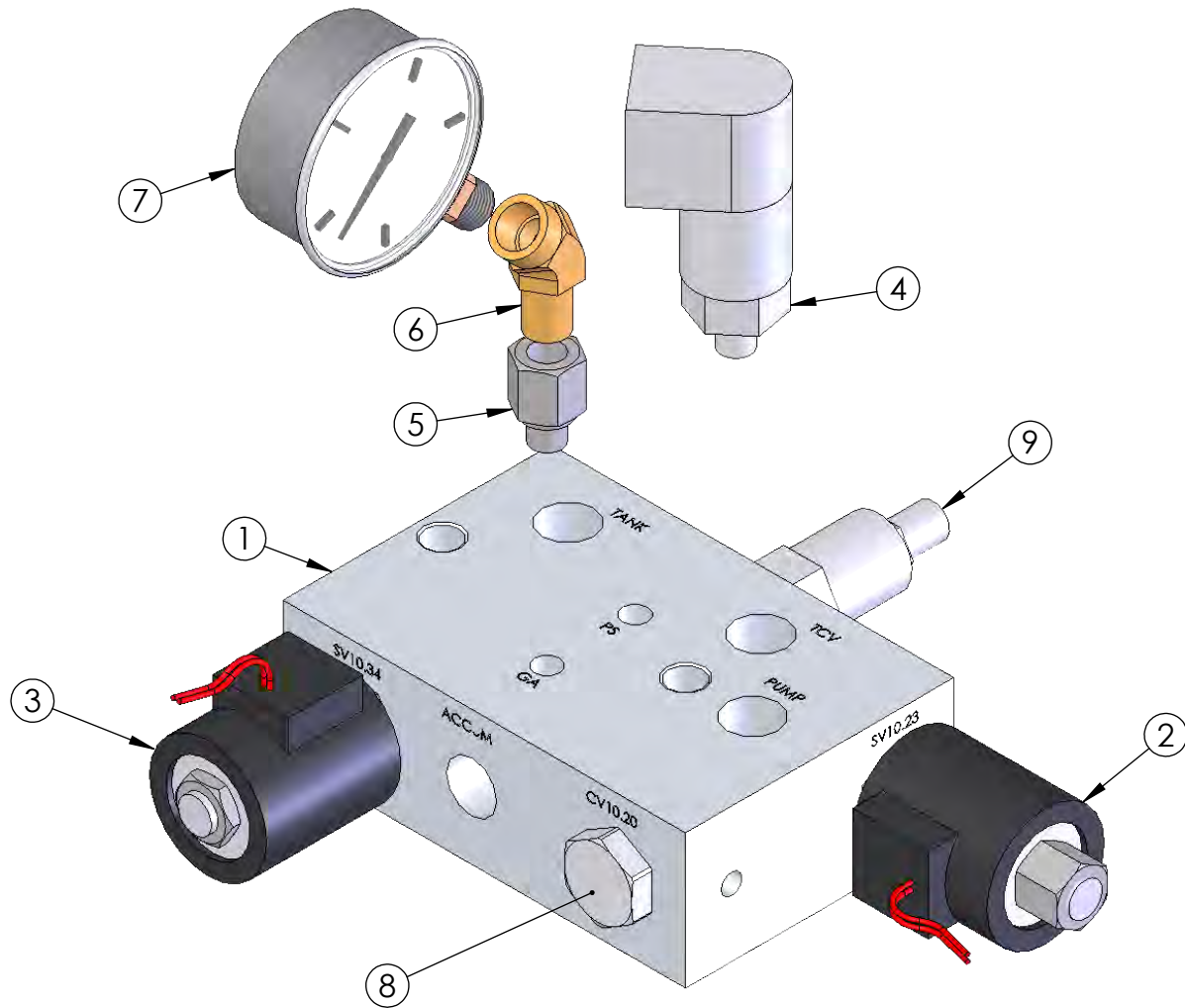

ITEM NO.	PART NUMBER	DESCRIPTION	QTY.
1	M04001	Manifold, Brake	1
2	V02066	Valve, 2Way Solenoid Cartridge	1
3	V02069	Valve, 3Way Solenoid Cartridge	1
4	S40001	PDI Switch	1
5	F05706	Fitting, 4-4 FNPT-SAE	1
6	F05018	-4 FNPT to -4 NPT 45°	1
7	G02055	3K bottom mount	1
8	V02067	Valve, check	1
9	V02068	Valve, relief	1

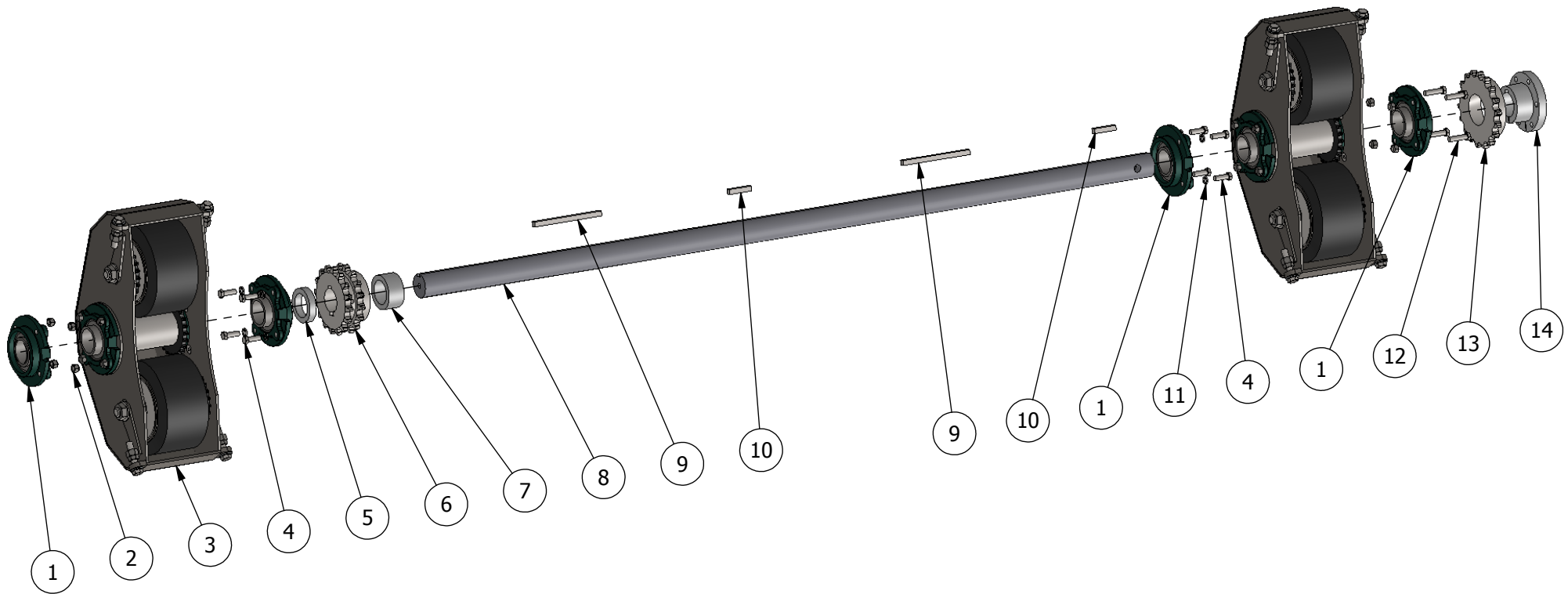

ITEM NO.	PART NUMBER	DESCRIPTION	QTY.
1	B07198	Bearing, SC Pilot Flange 2-7/16"	4
2	N04555	Nut, Hex Nylock® 1/2-13	8
3	Power Head	See Power Head Sheet	2
4	B11368	Bolt Hx head 1/2-13x1-1/2	8
5	S24105	Spacer, 3/4"	1
6	S29004	Sprocket	1
7	S24106	Spacer, 1-3/4"	1
8	S43125	Shaft, Drive	1
9	K01020	Key, 1/2 x 1/2 x 7-3/4	2
10	K01010	Key, 1/2 x 1/2 x 2-1/2	2
11	W01565	Washer, Split Lock 1/2"	8
12	B11366	Bolt Hx head 1/2-13x2	4
13	S29023	Sprocket, Drive	1
14	B21055	Shaft Collar	1

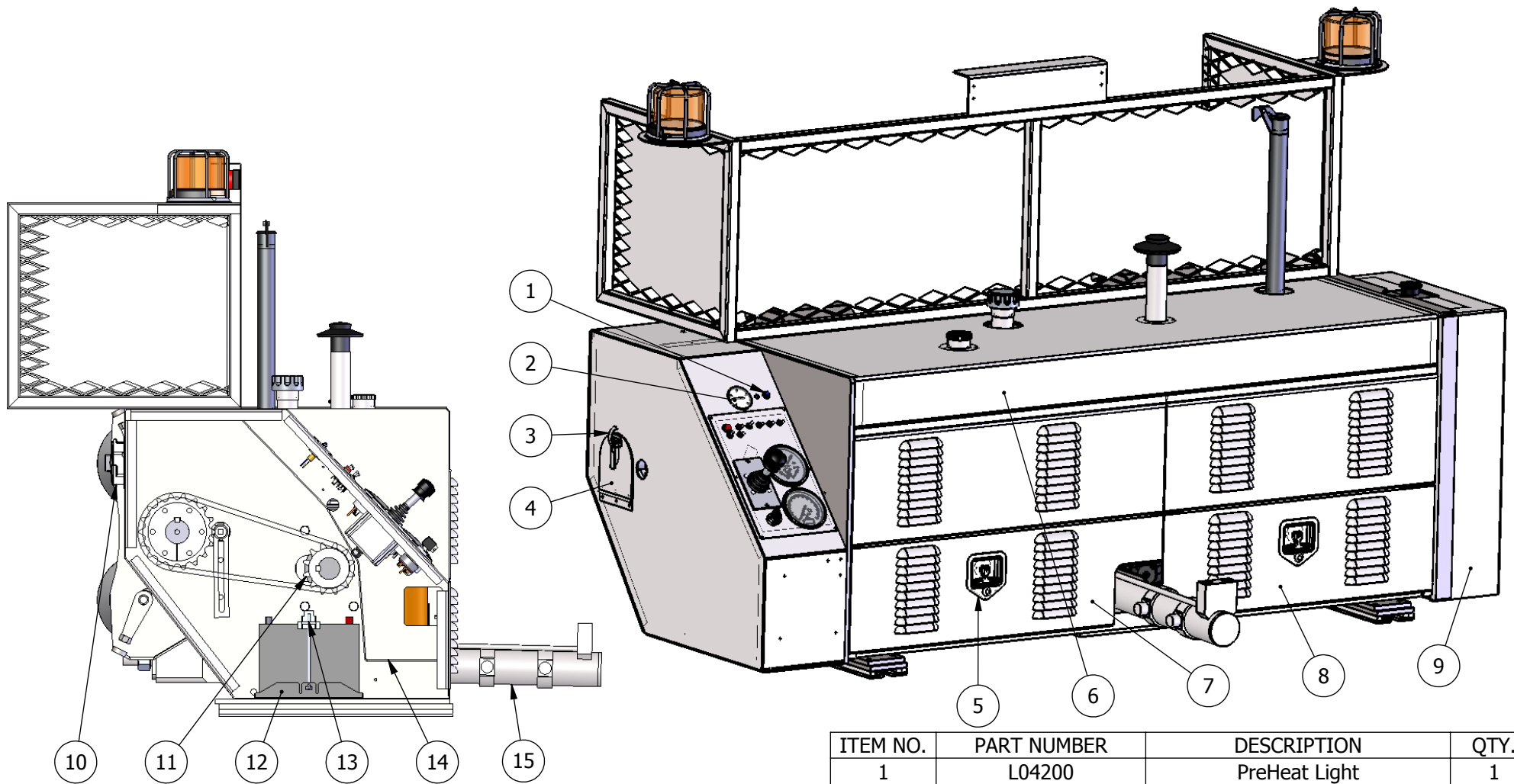

ITEM NO.	PART NUMBER	DESCRIPTION	QTY.
1	L04200	PreHeat Light	1
2	G02075	Gauge, 5000 PSI	1
3	L01020	Latch, Over center	1
4	C29083	Cover, Driveshaft Capstan	1
5	L08025	Lock, T-Handle	2
6	H05700	Hood, Power Unit	1
7	D05205	RH PU Door	1
8	D05204	LH PU Door	1
9	C29200	Radiator Cover	1
10	H10020	Registration Holder	1
11	S29933	Sprocket	1
12	H10060	Tray, battery	1
13	R19025	Battery hold down	1
14	G09200	Guard, Chain	1
15	C32050	Cylinder, Power Unit	1



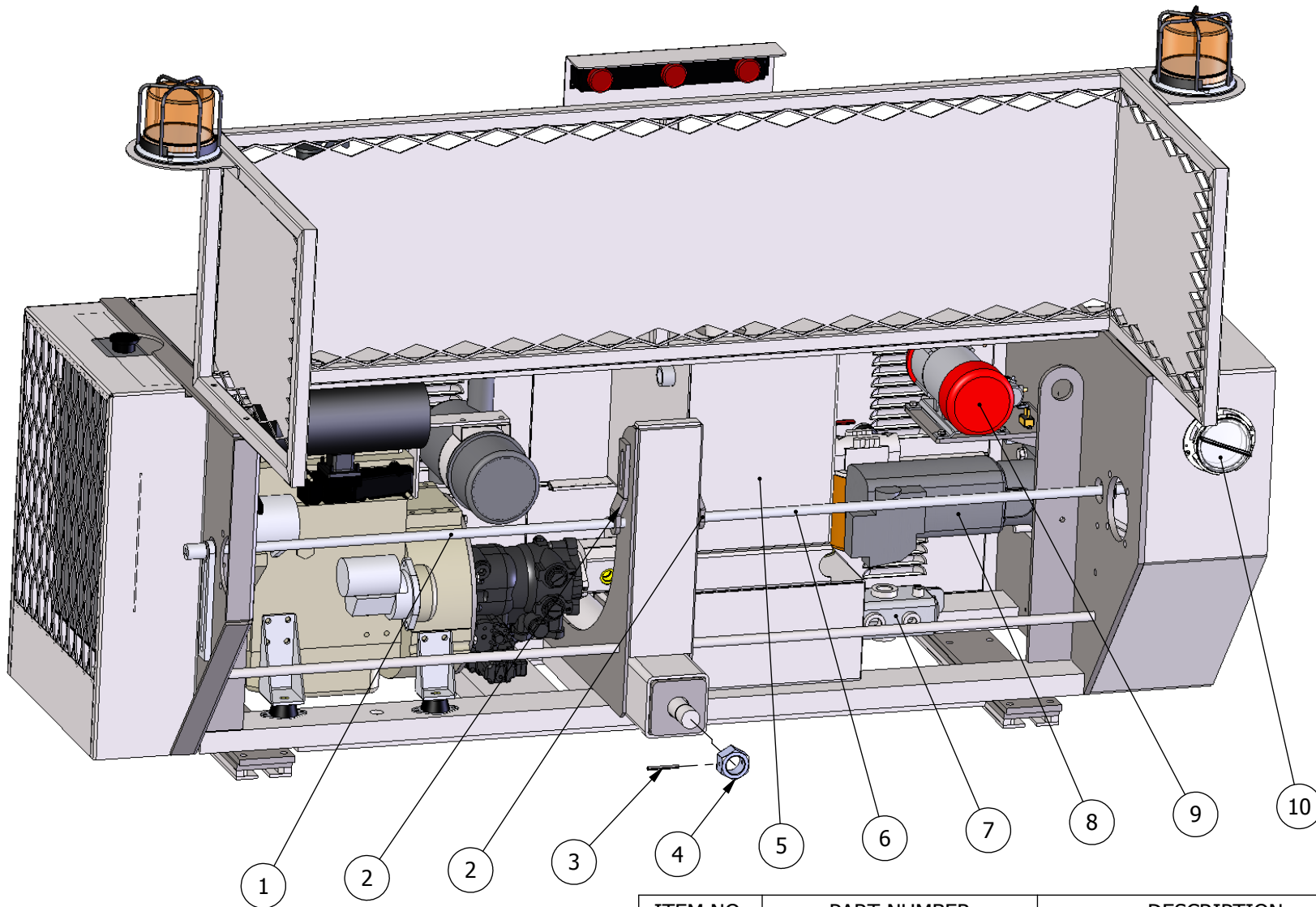

ITEM NO.	PART NUMBER	DESCRIPTION	QTY.
1	S04015	Screw, Acme	1
2	B15980	Bracket, Acme Screw Adjust	2
3	P06193	Pin, Roll 1/4 x 2-1/2	1
4	N04130	Nut 1 1/2-12 Z	1
5	Tank Assembly	See Tank Assy Sheet	1
6	S04153	Screw, Acme Long	1
7	M04043	Manifold Assembly	1
8	M08010	Hydra Motor	1
9	HYBAC	Air Brake Compressor Option	1
10	H10020	Registration Holder	1

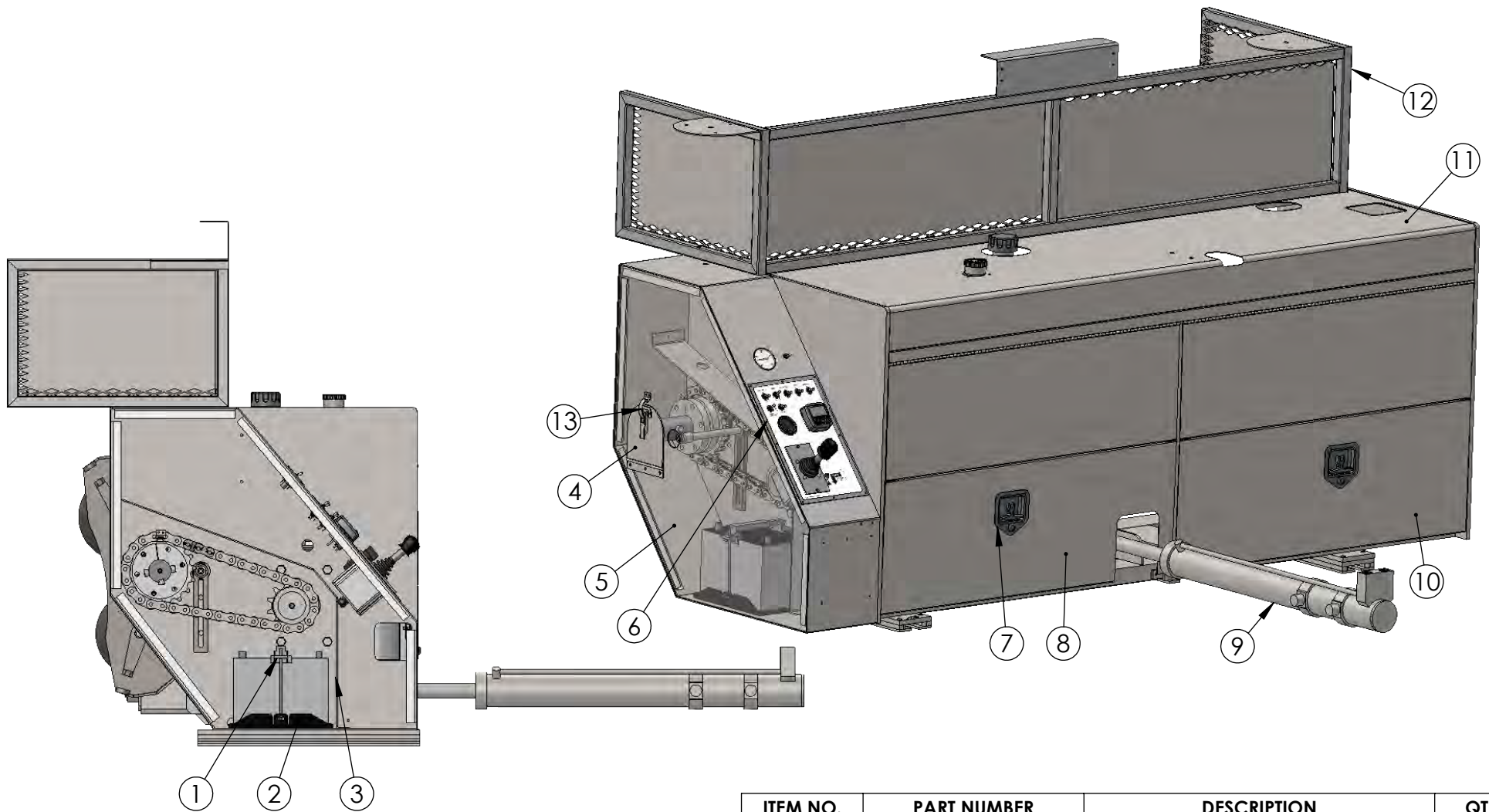

ITEM NO.	PART NUMBER	DESCRIPTION	QTY.
1	R19025	Battery hold down	1
2	H10060	Tray, battery	1
3	G09217	Guard, Chain 985 T4f	1
4	C29083	Cover, Driveshaft Capstan	1
5	C29009	Cover, Side Control Panel	1
6	985 Front Controls T4	See Controls Sheet	1
7	L08025	Lock, T-Handle	2
8	D05208	Door, Curbside	1
9	C32050	Cylinder, PowerUnit	1
10	D05209	Door, Streetside	1
11	H05007	Hood, Powerunit	1
12	S08043	Screen, Operator Safety	1
13	L01020	Latch, Over center	1

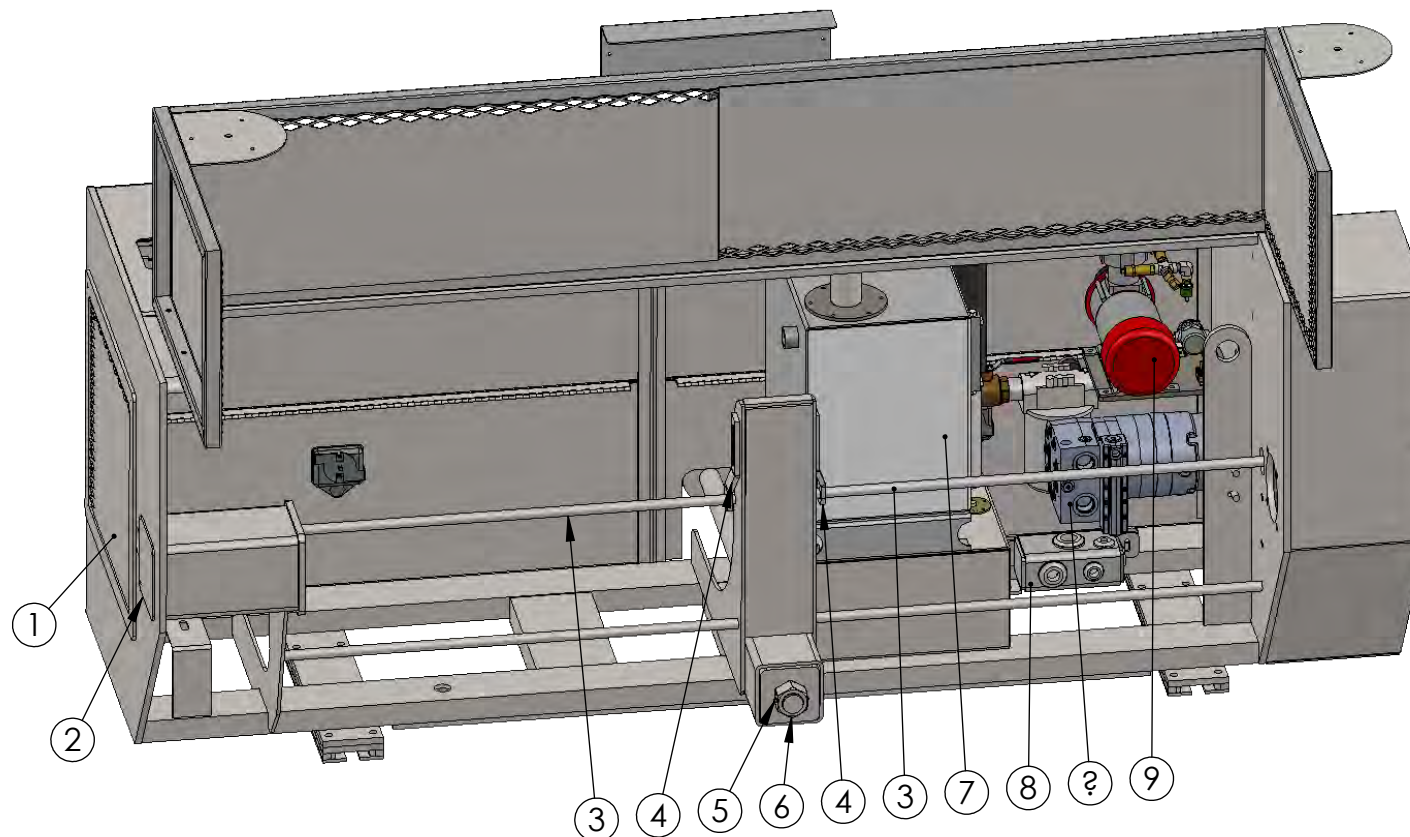

ITEM NO.	PART NUMBER	DESCRIPTION	QTY.
1	C29235	Cover, Radiator	1
2	C29207	Cover, Shaft	1
3	S04153	Screw, Acme Long	2
4	B15980	Bracket, Acme Screw Adjust	2
5	P06193	Pin, Roll 1/4" x 2-1/2"	1
6	N04130	Nut, Hx 1-1/2"-12 Z	1
7	985 Std Tanks T4f	See Tanks Sheet	1
8	M04043	Manifold	1
9	HYBAC	Air Brake Compressor Option	1

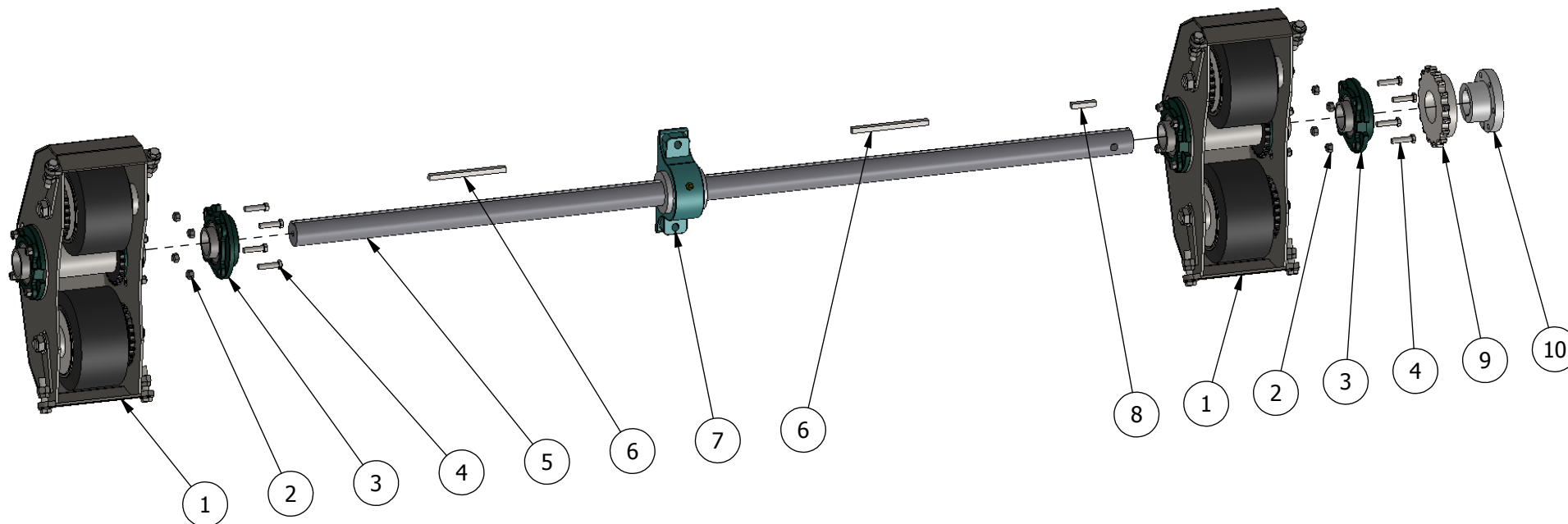

**Drive Chain Slack Range: 1/4"-3/4"**

ITEM NO.	PART NUMBER	DESCRIPTION	QTY.
1	Power Head	See Power Head Sheet	2
2	N04555	Nut, Hex Nylock® 1/2-13	8
3	B07198	Bearing, SC Pilot Flange 2-7/16"	2
4	B11366	Bolt Hx head 1/2-13x2	8
5	S43125	Shaft, Drive	1
6	K01020	Key, 1/2 x 1/2 x 7-3/4	2
7	B07275	Bearing, 2-7/16 Pillow Block	1
8	K01010	Key, 1/2 x 1/2 x 2-1/2	1
9	S29023	Sprocket, Drive	1
10	B21055	Shaft Collar	1

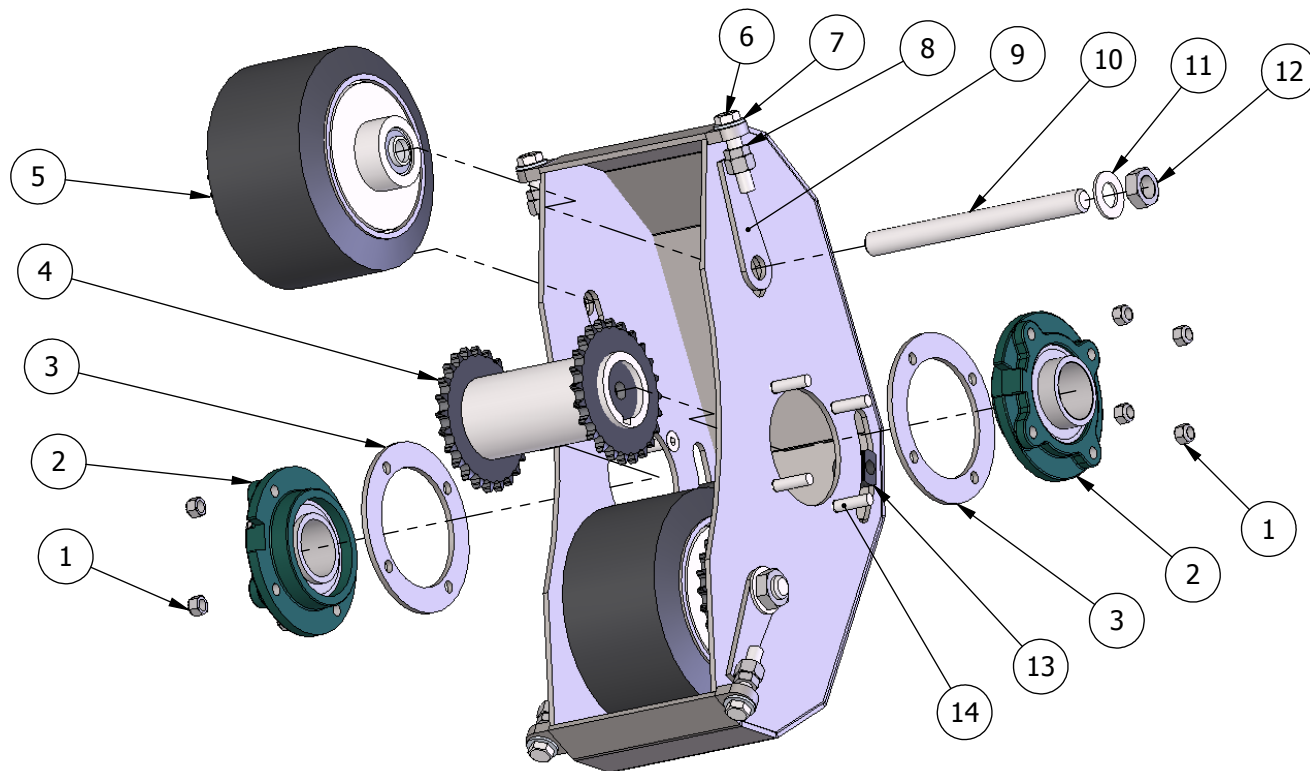

**Drive Roller Chain Slack Range: 1/4"-1/4"**

ITEM NO.	PART NUMBER	DESCRIPTION	QTY.
1	N04555	Nut, Hex Nylock® 1/2-13	8
2	B07198	Bearing, SC Pilot Flange 2-7/16"	2
3	S24104	Plate, 1/4" A36	2
4	S29940	Sprocket, Double	1
5	Drive Roller	See Drive Roller Sheet	2
6	B11083	Bolt Hx head 5/8-11x3	4
7	W01053	Washer, Flat 5/8	4
8	N04562	Nut Hex Jam 5/8-11	4
9	B15968	Bracket, Drive Roller Adjusting	4
10	A07055	Rod, Chrome 1"	2
11	W01294	Washer Flat SAE 1	4
12	N04095	Nut Hex Jam 1-14	4
13	N04098	Nut, Acme Screw	2
14	S04560	Screw FSHCS 1/2-13x2	8
15	H08045	Roller Housing	1



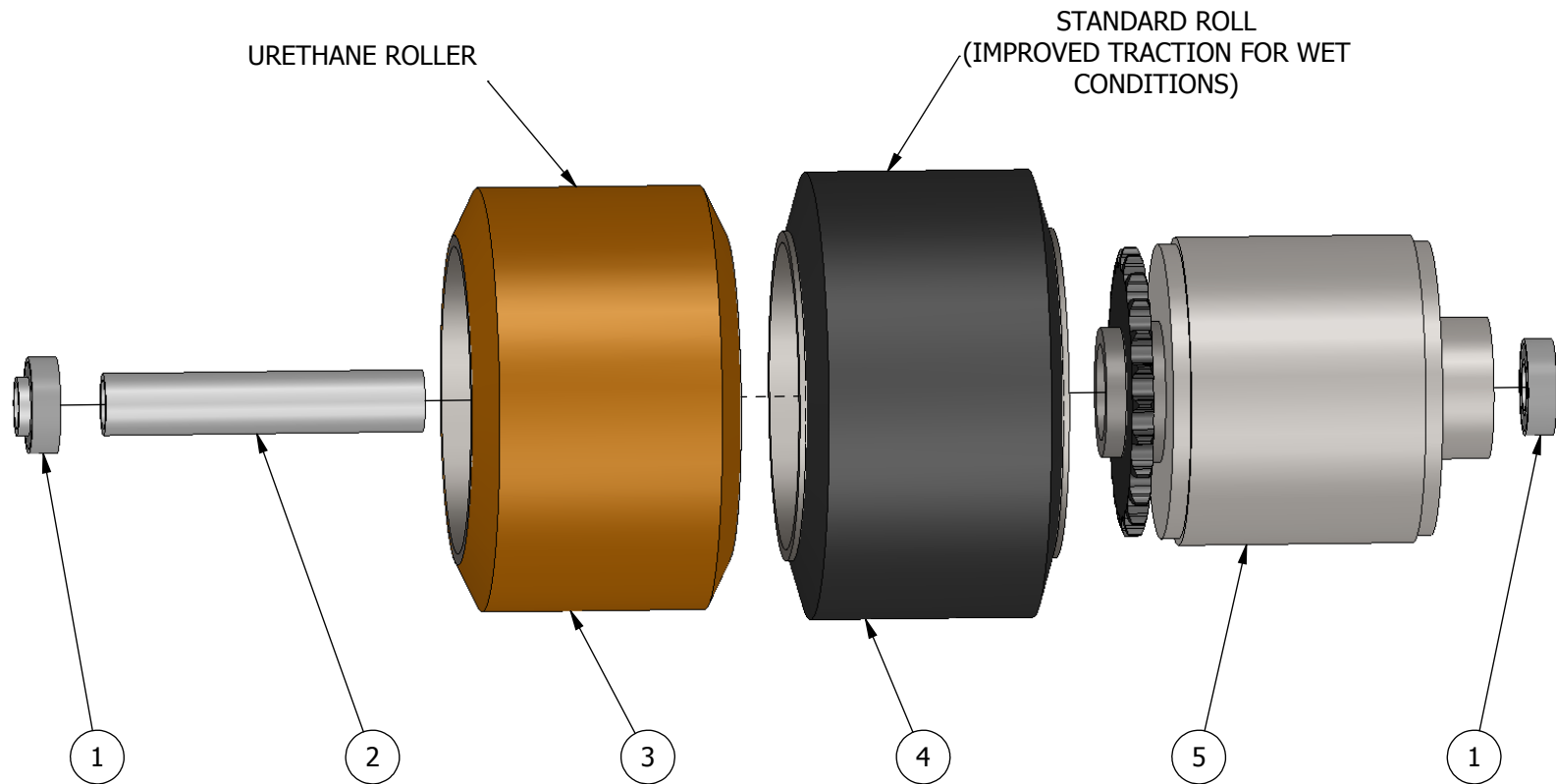

ITEM NO.	PART NUMBER	DESCRIPTION	QTY.
1	B07135	Bearing, 1" I.D.	2
2	S24010	Spacer, Drive Roller	1
3	R18024	Roller, Drive Urethane	1
4	R18025	Roller, Drive Rubber	1
5	C27005	Core, Drive Roller Standard	1

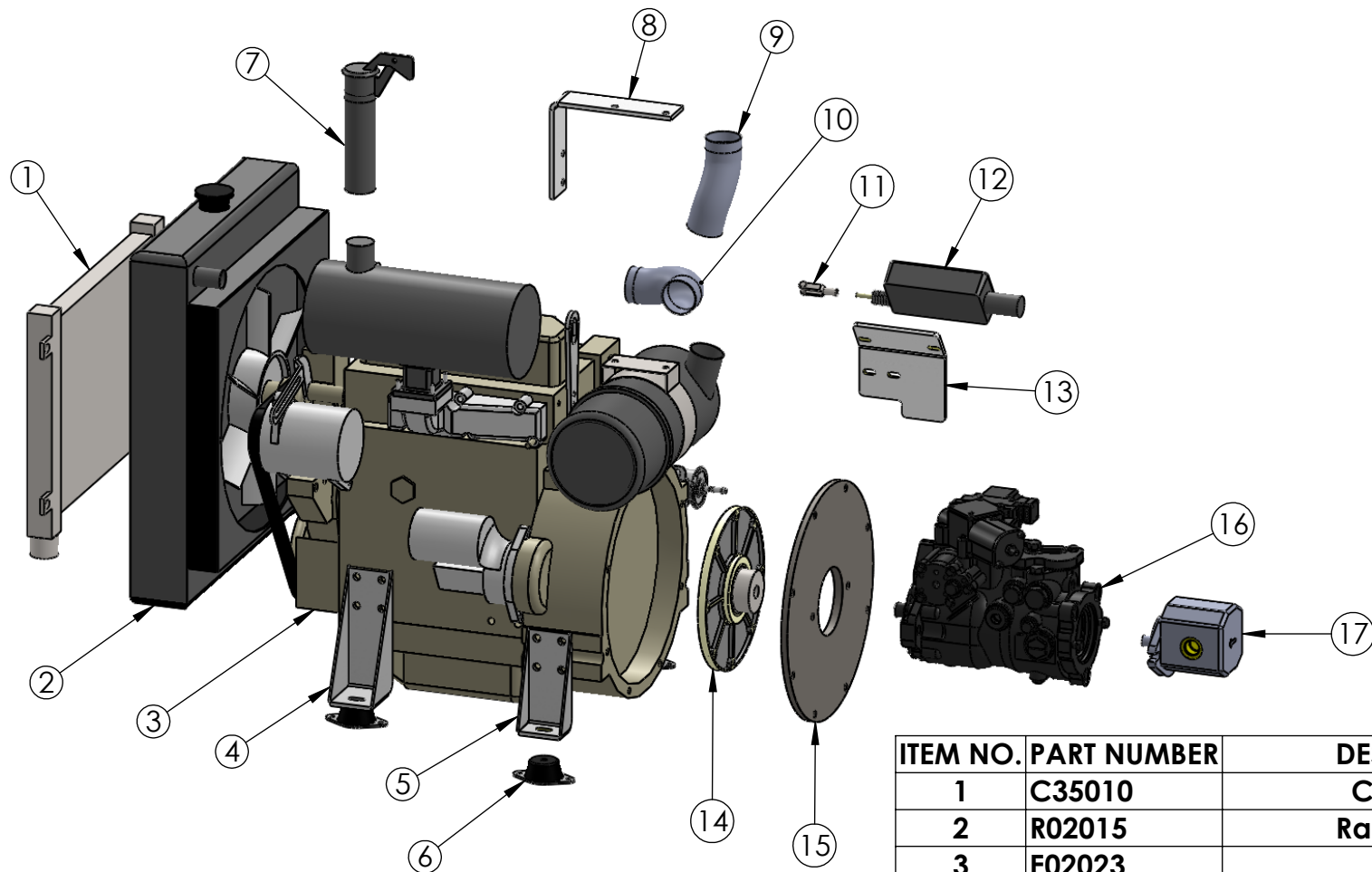

ITEM NO.	PART NUMBER	DESCRIPTION	QTY.
1	C35010	Cooler, Oil	1
2	R02015	Radiator JDD	1
3	E02023	3TNV88	1
4	M09008	Mount, Front Engine 3TNV88	2
5	M09009	Mount, Rear Engine 3TNV88	2
6	I04003	Insulator, Small	4
7	P07400	Pipe, Exhaust 3TNV88	1
8	B15988	Bracket, Air Cleaner	1
9	H07712-9-1	2"ID x 9" long	1
10	H07712-9-2	2"ID x 9" long	1
11	Y01055	Yoke, 1/4" clevis	1
12	C34010	Controller, Electronic Throttle	1
13	M09003	Mount, Throttle	1
14	C28026	Pump Coupler/ Flywheel	1
15	P09097	Pump Adapter Plate	1
16	P20070	Pump, Hydraulic	1
17	P20103	Pump, 10gpm	1

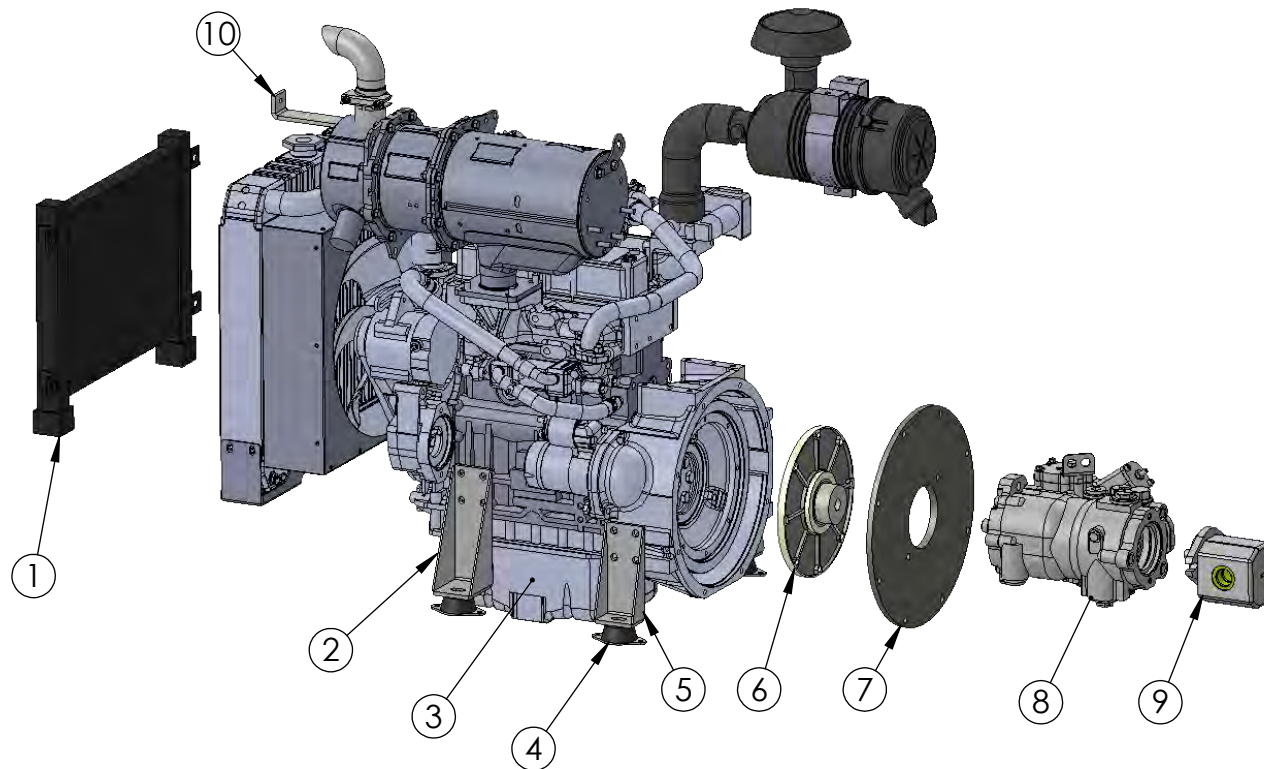

ITEM NO.	PART NUMBER	DESCRIPTION	QTY.
1	C35010	Cooler, Oil	1
2	M09041	Mount engine front	2
3	E02033	Engine	1
4	I04003	Insulator, Small	4
5	M09042	Mount engine rear	2
6	C28026	Pump Coupler/ Flywheel	1
7	P09097	Pump Adapter Plate	1
8	P20070	Pump, Hydraulic	1
9	P20103	Pump, 10gpm	1
10	B15171	Bracket, Radiator 985 T4f	1

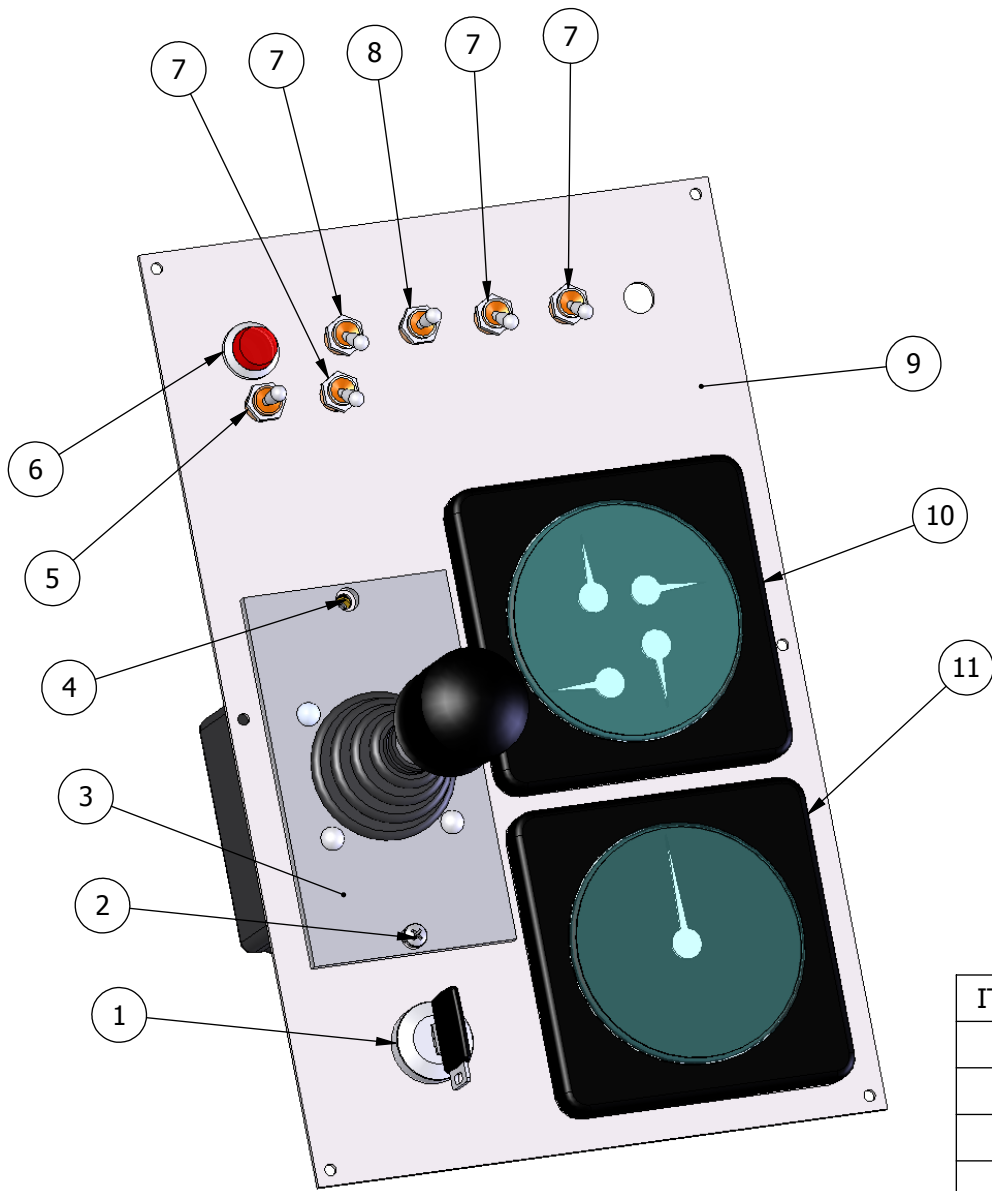

ITEM NO.	PART NUMBER	DESCRIPTION	QTY.
1	S41100	Switch Ignition JDD	1
2	S04601	10-32 X 3/4" PAN HEAD	1
3	C34030	Controller, Joystick MCH	1
4	S41001	JD Pre-Heat Timer	1
5	S40150	Switch, DP/DT Momentary	1
6	L04025	Light, Pilot	1
7	S40008	Switch, SP/DT Maintained	4
8	S40153	Switch, SP/DT Maintained w/center	1
9	P03020	Control Panel	1
10	G02003	Gauge, 4 Gauge Cluster	1
11	G02002	Gauge, Tachometer VDO	1

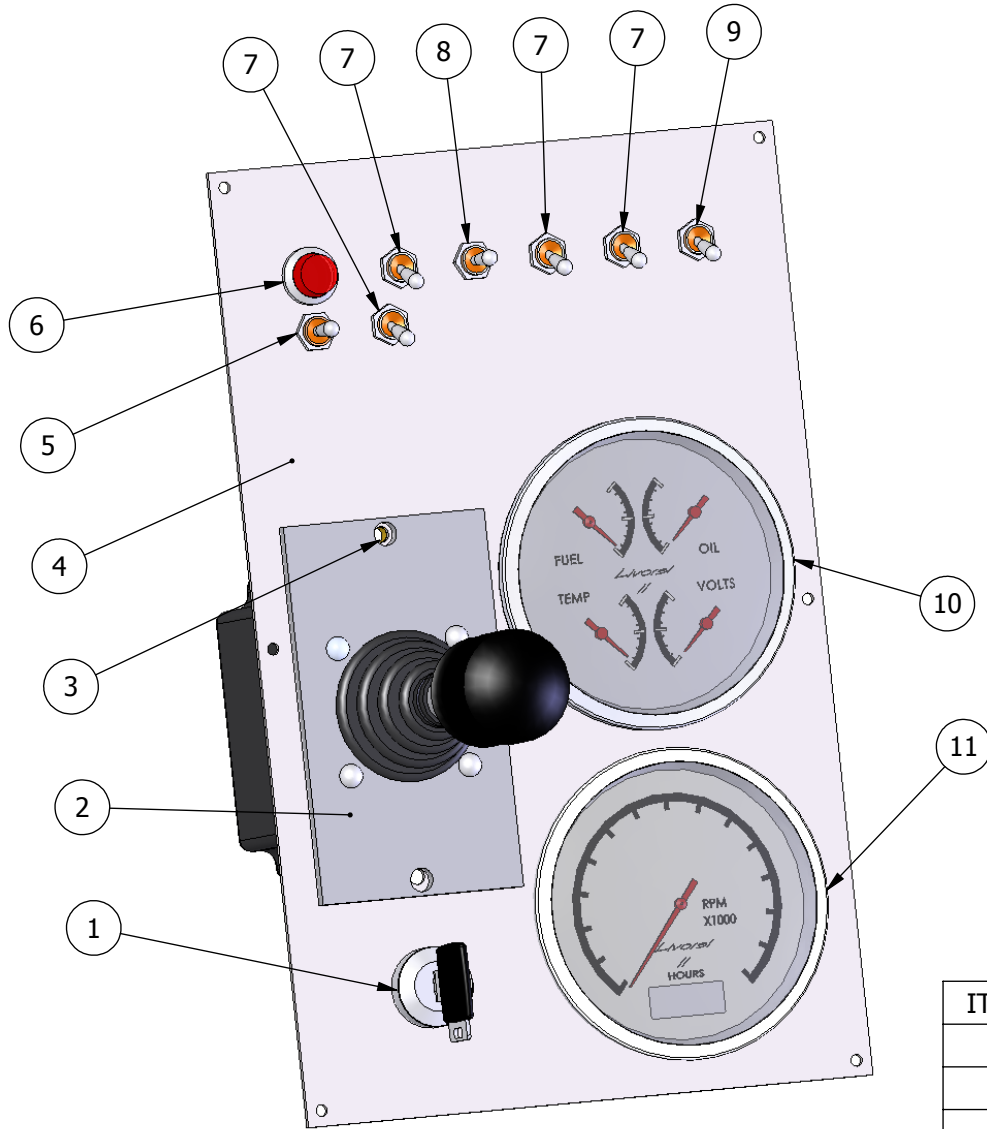

ITEM NO.	PART NUMBER	DESCRIPTION	QTY.
1	S41100	Switch Ignition JDD	1
2	C34030	Controller, Joystick MCH	1
3	S41001	JD Pre-Heat Timer	1
4	P03020	Control Panel	1
5	S40150	Switch, DP/DT Momentary	1
6	L04025	Light, Pilot	1
7	S40008	Switch, SP/DT Maintained	4
8	S40153	Switch, SP/DT Maintained w/center	1
9	S40035	Switch, SP/ST Toggle	1
10	G02033	Gauge, Livorsi 4 in 1	1
11	G02022	Livorsi Tachometer	1

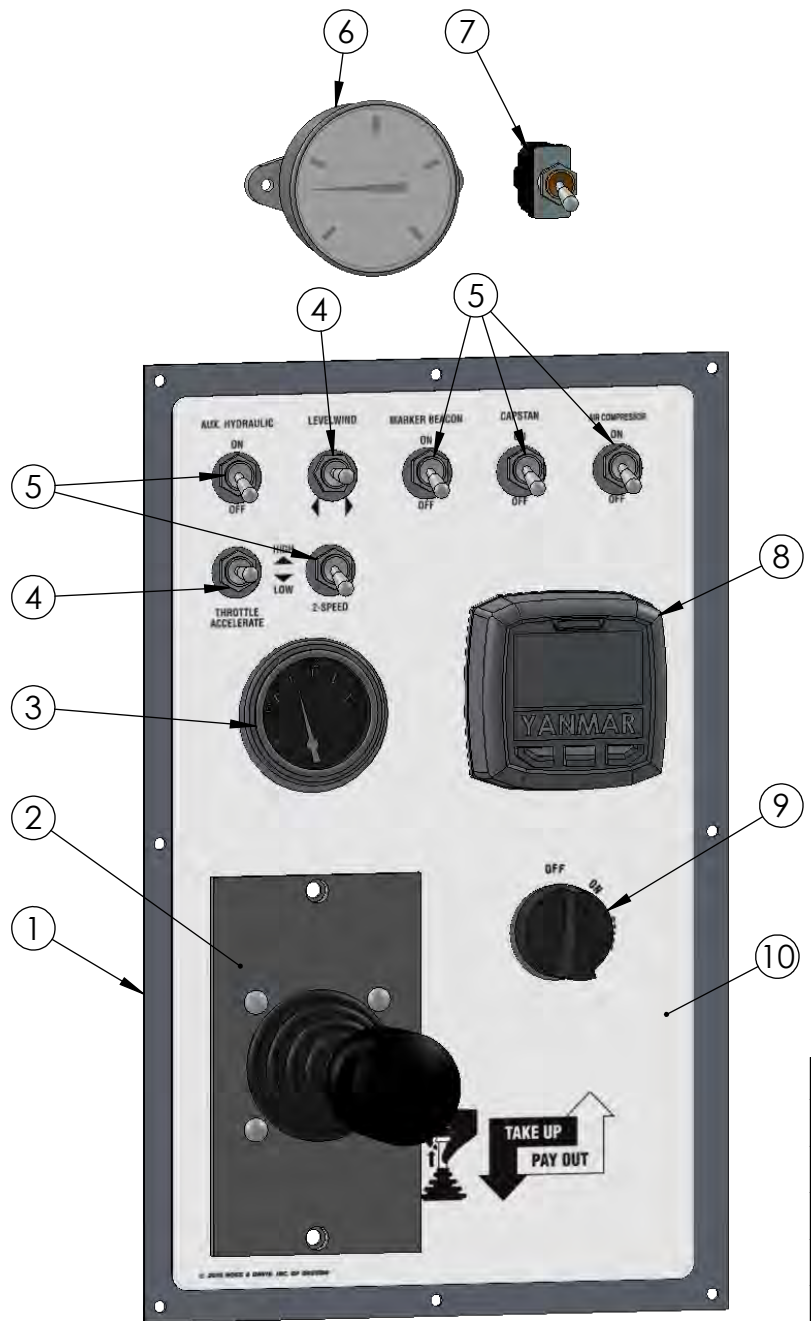

ITEM NO.	PART NUMBER	DESCRIPTION	QTY.
1	P03023	Panel, Control	1
2	C34030	Controller, Joystick MCH	1
3	G02005	Gauge, Fuel Level	1
4	S40100	Switch, SP/DT Momentary	2
5	S40035	Switch, SP/ST Toggle	5
6	G02075	5000 PSI GAUGE back mount	1
7	S40008	Switch, SP/DT Maintained	1
8	K02707	Display, Yanmar T4 w/ Keyswitch	1
9	S40070	Switch, Key Cole Hersee	1
10	D30150	Decal, Control Panel T4f	1

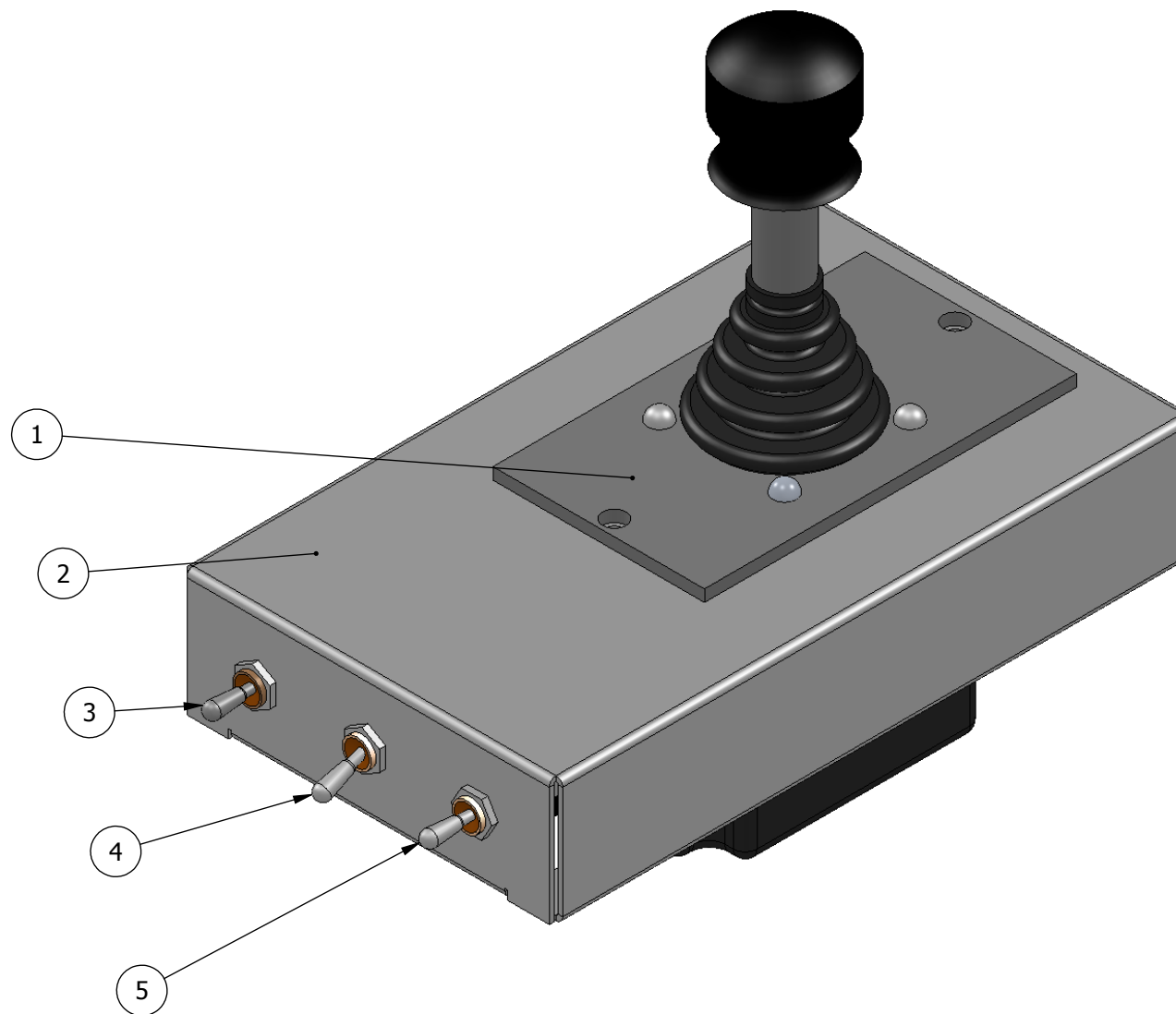

ITEM NO.	PART NUMBER	DESCRIPTION	QTY.
1	C34030	Controller, Joystick MCH	1
2	B13960	Rear Control Panel	1
3	S40150	Switch, DP/DT Momentary	1
4	S40035	Switch, SP/ST Toggle	1
5	S40100	Switch, SP/DT Momentary	1

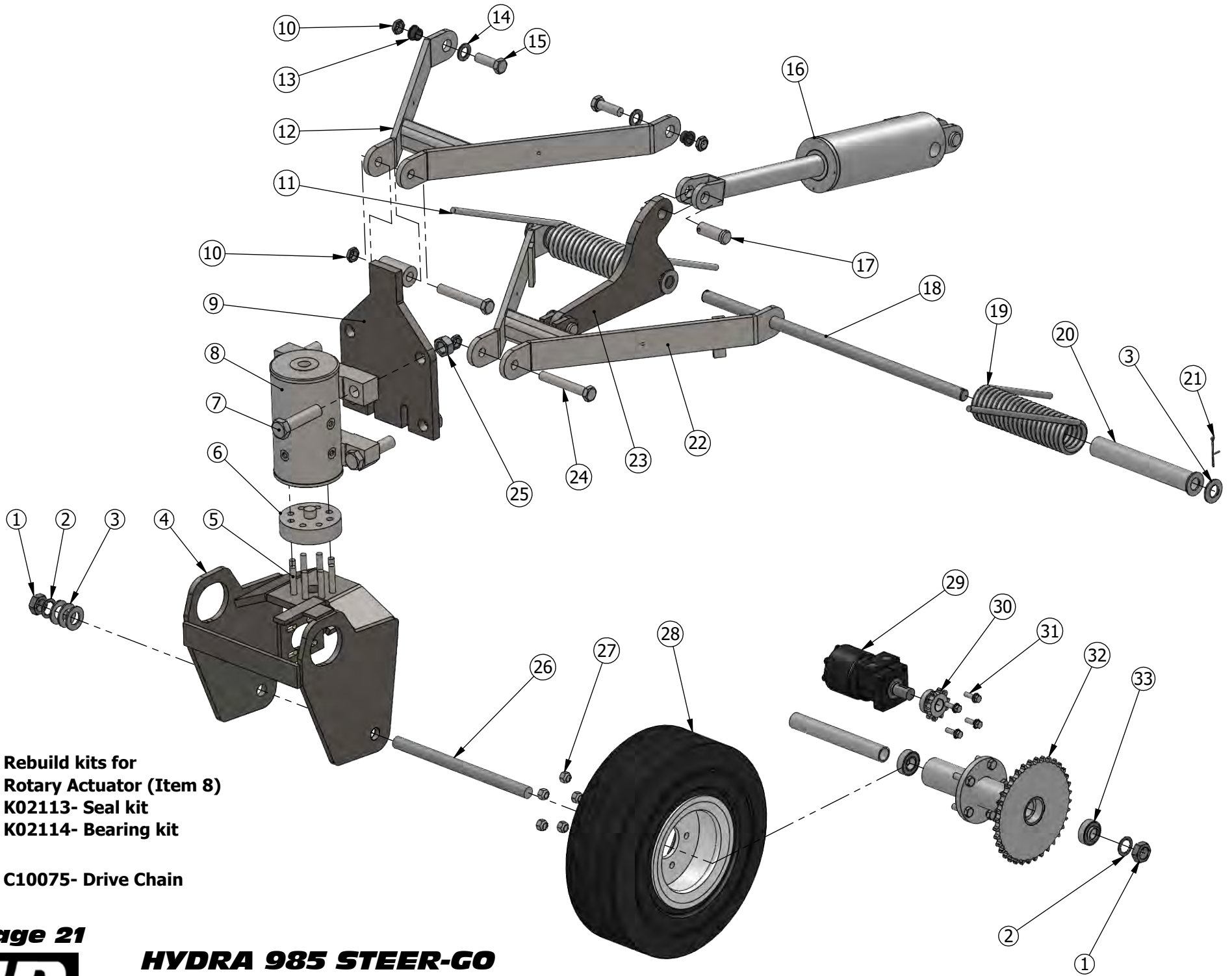

Rebuild kits for  
Rotary Actuator (Item 8)  
K02113- Seal kit  
K02114- Bearing kit  
  
C10075- Drive Chain





ITEM NO.	PART NUMBER	DESCRIPTION	QTY.
1	N04095	Nut, Hx Jam 1"-14	2
2	W01090	Washer, Internal Lock 1"	2
3	W01294	Washer, Flat SAE 1"zinc	7
4	F08912A	Fork, Hydra Idler Wheel	1
5	B11605-S	Bolt, Hx Head 1/2"-13 x 3" special	8
6	S24009	Spacer, Actuator	1
7	B11482	Bolt, Hx Head 1"-8 x 4" Z8	4
8	A01050	Actuator, Rotary	1
9	M09010	Mount, Actuator plate	1
10	N04587	Nut, Hx Jam Nylock® 3/4"-16	4
11	S28102	Spring, 985 Torsion, RH	1
12	F09005	Frame, Upper A-arm	1
13	B07365	Bearing, I-Glide 3/4x1x5/8	2
14	W01285	Washer, Flat SAE 3/4"zinc	2
15	B11460	Bolt, Hx Head 3/4"-16 x 2-1/4" Z8	2
16	C32030	Cylinder, Drawbar	1
17	P06070	Pin, 1x2-1/2	2
18	S43099	Shaft, Lower A-arm Pivot	1
19	S28101	Spring, 985 torsion, LH	1
20	S24070	Spacer, Torsion Spring	2
21	P06948	Pin, 3/16x2 Cotter	5
22	F09020	Frame, Lower A-arm	1
23	A08015	Plate 3/4" A36	1
24	B11449	Bolt, Hx Head 3/4"-16 x 5" Z8	2
25	N11482	Nut, Hx Toplock 1"-8 Z8	4
26	A07015	Axle, Drive Wheel	1
27	N04040	Nut, Lug 1/2"-20 Z	5
28	W03907A	Wheel and Tire assy 18x7	1
29	M08050	Motor, Hydraulic Drive	1
30	S29005	Sprocket, Drive	1
31	B11343	Bolt, Hx Head 3/8"-16 x 1-1/4"	4
32	S29905A	Sprocket and Hub Assembly	1
33	B07135	Bearing, 1" I.D.	2



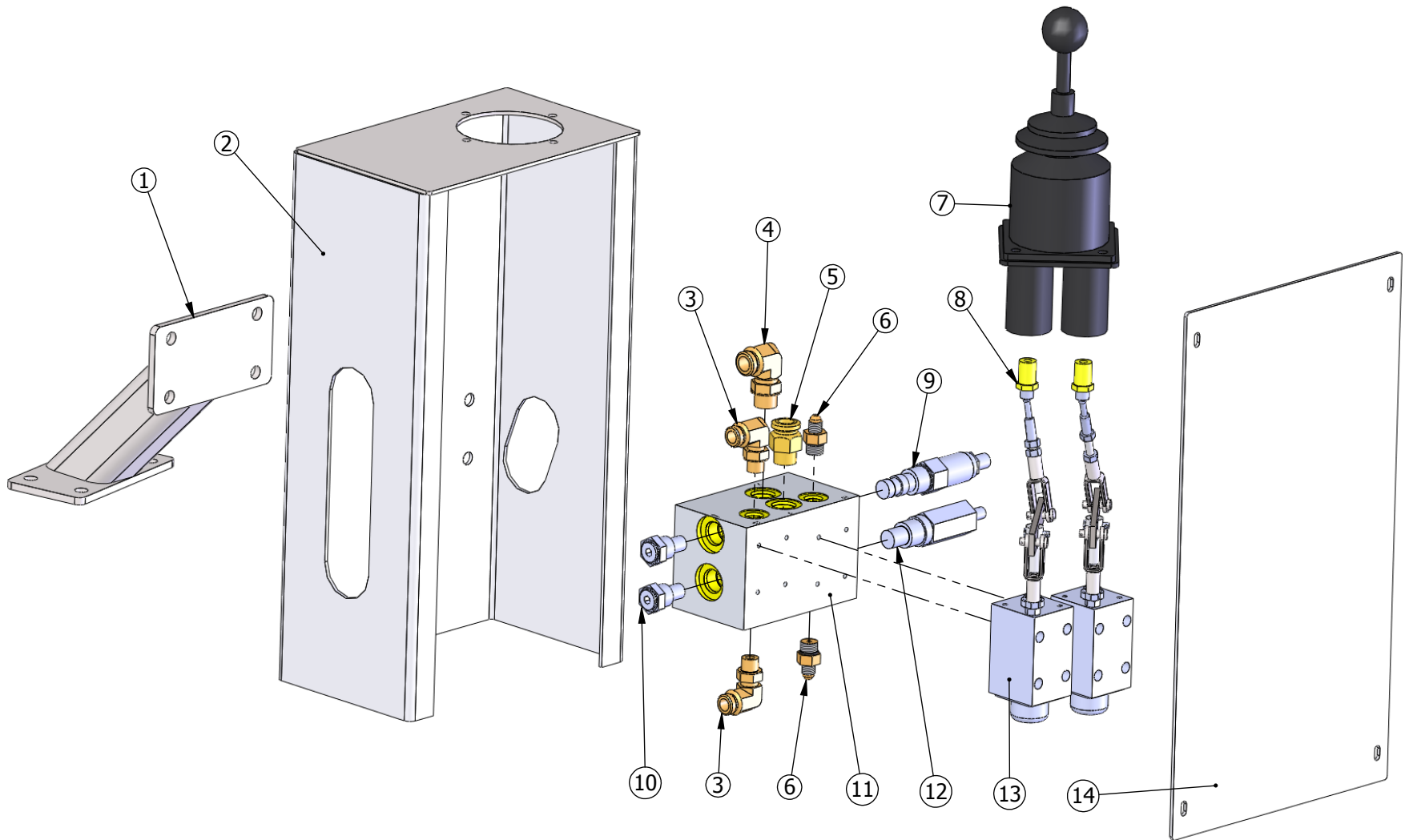

ITEM NO.	PART NUMBER	DESCRIPTION	QTY.
1	B15093	Bracket, Steer-Go Box	1
2	B13930	Box Steer-Go	1
3	F05324	Fitting, 6-6 90° STC	2
4	F05326	Fitting, 8-8 90° STC	1
5	F05322	Fitting, 8-8 STR STC	1
6	F05754	Fitting, 4-6 Str SAE	2
7	L03055	Lever, Steer-Go Joystick	1
8	K02500	Kit, Linkage	2
9	V02401	Valve, Priority Flow	1
10	V02185	Valve, Check	2
11	M04015	Manifold Steer-Go	1
12	V02186	Valve, Relief	1
13	V02021	Valve, Directional	2
14	C29120	Cover, Steer-Go	1



**If items look different from the parts breakdown please call for assistance. (541)354-1001**

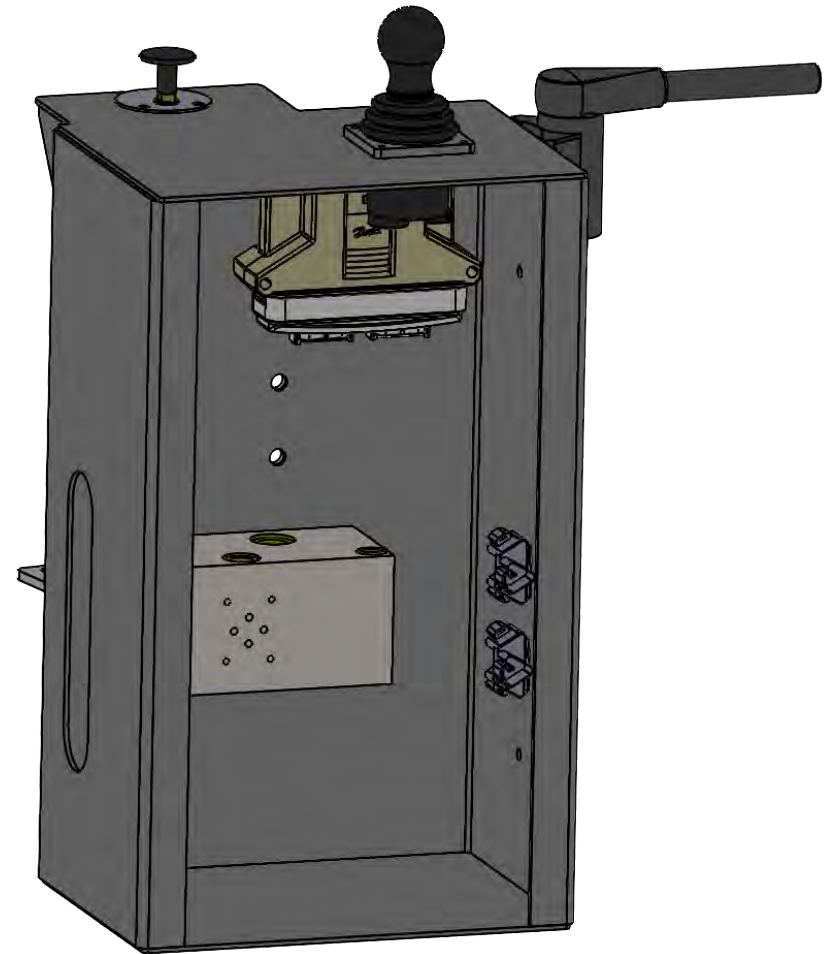
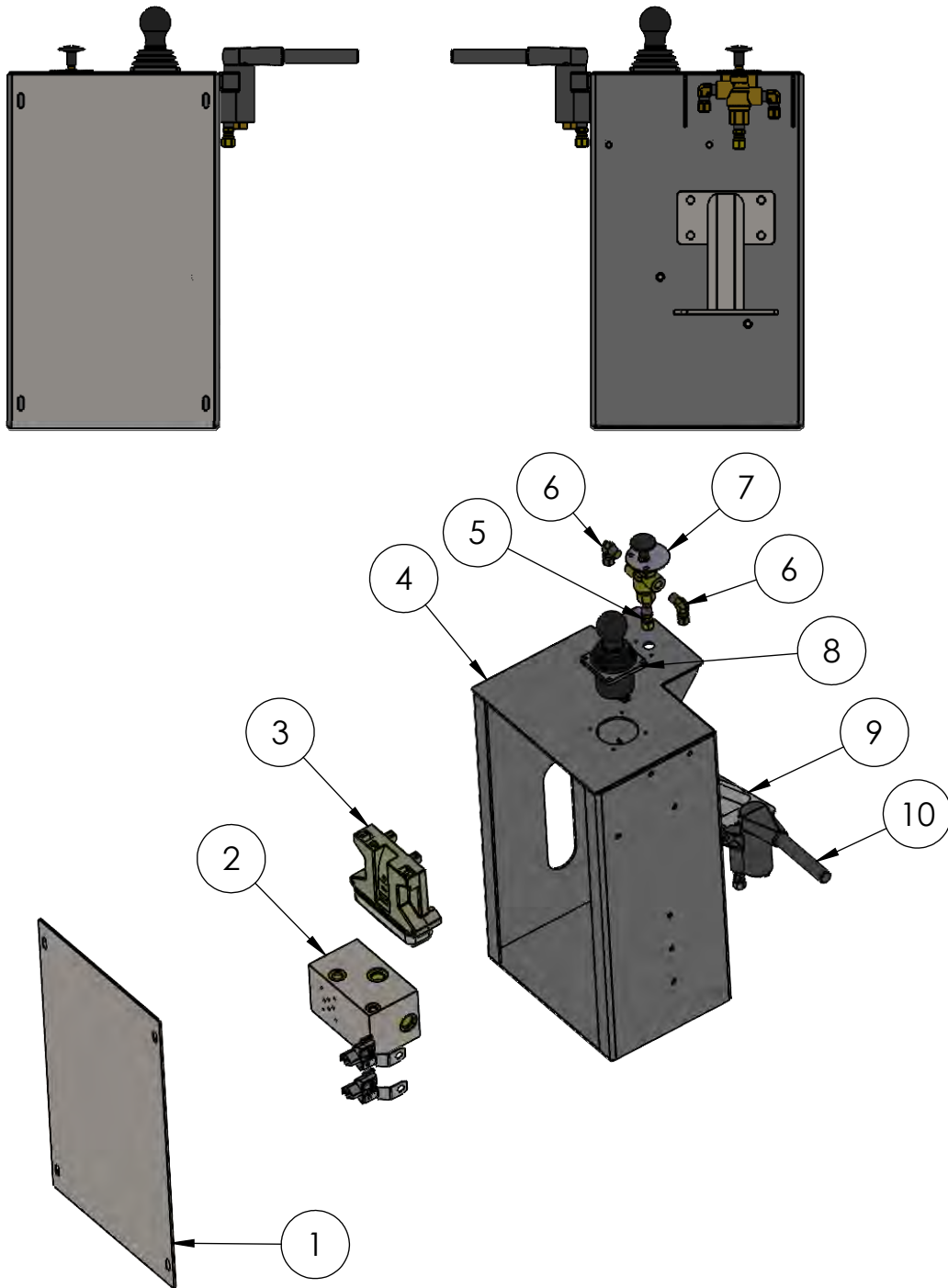

ITEM NO.	PART NUMBER	DESCRIPTION	QTY.
1	C29121	Cover, Electric Steergo	1
2	C34039	Manifold HYPSE-E	1
3	C34101	Controller, 24 Pin	1
4	B13935	Box, Steergo Electric	1
5	F05413	Fitting Brass Str 68NTA-6-4	3
6	F05438	Fitting, Air 90° 6-4	2
7	V02008	Valve, Cab control	1
8	C34037	JS1000 Joystick Steer-Go	1
9	B15093	Bracket, Steer-Go Box	1
10	V02018	Valve, Trolley Air	1

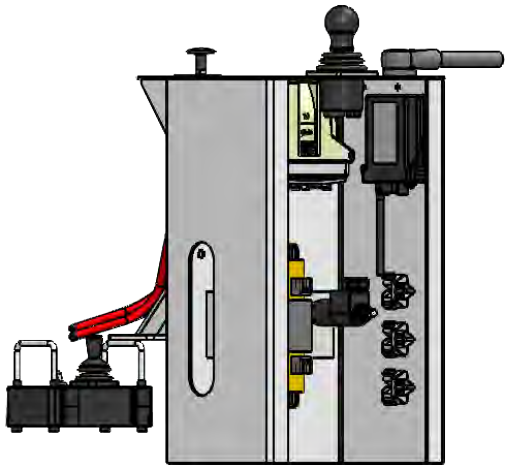
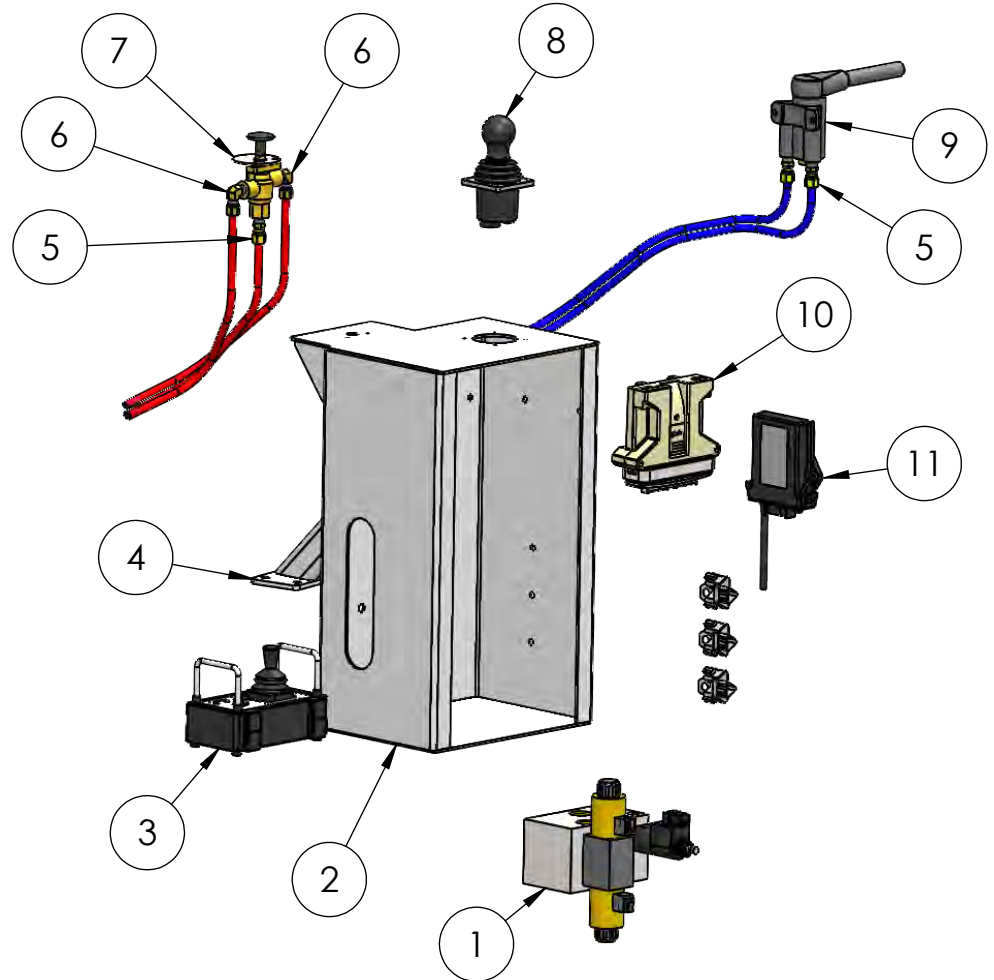
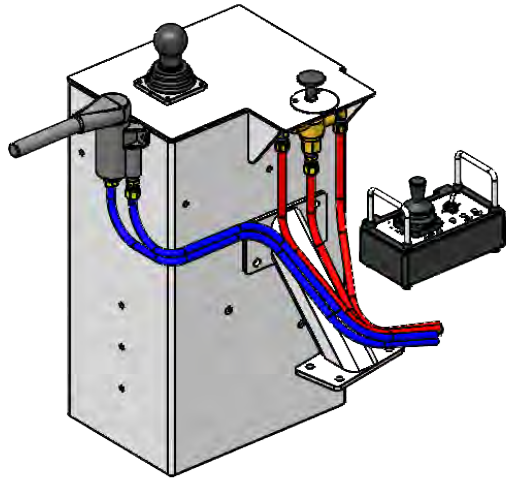

ITEM NO.	PART NUMBER	DESCRIPTION	QTY.
1	C34039	Manifold Steer-Go Electronic	1
2	B13935	Box, Steergo Electric	1
3	R13006	Remote, Control Box	1
4	B15093	Bracket, Steer-Go Box	1
5	F05413	Fitting Brass Str 68NTA-6-4	3
6	F05438	Fitting, Air 90° 6-4	2
7	V02008	Valve, Cab control	1
8	C34037	JS1000 Joystick Steer-Go	1
9	V02018	Valve, Trolley Air	1
10	C34101	Controler, 24 Pin	1
11	R13005	Remote, Reciever Kit	1

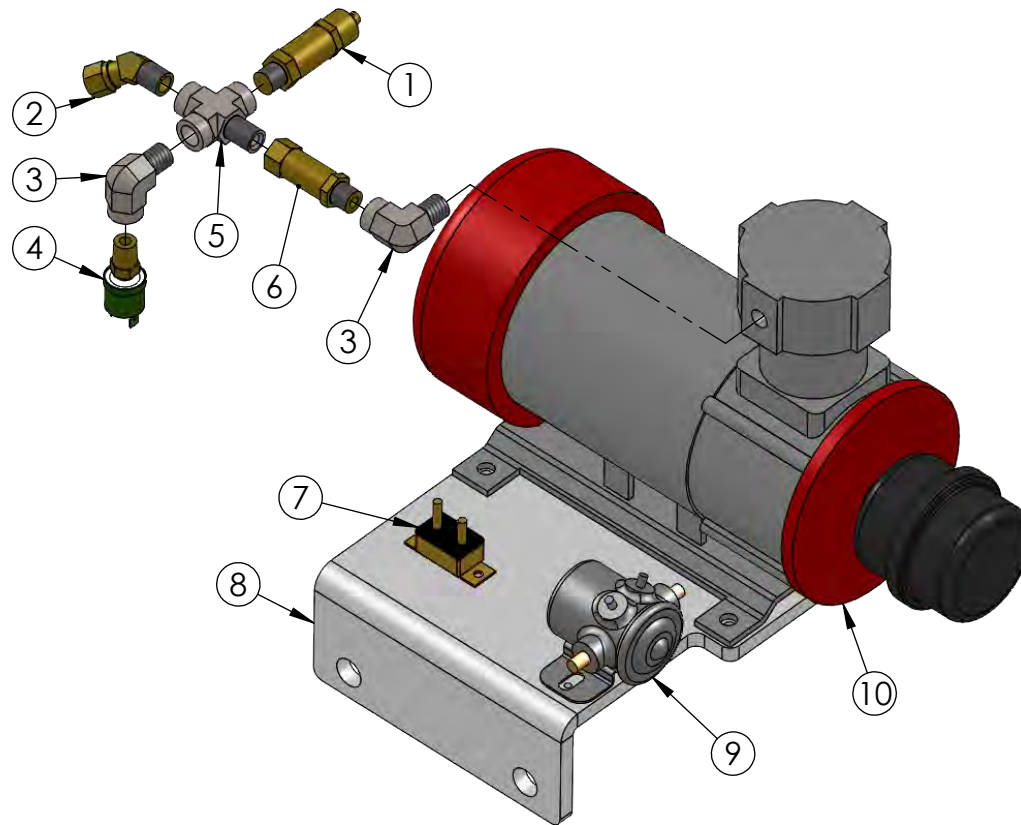

ITEM NO.	PART NUMBER	DESCRIPTION	QTY.
1	V02012	Valve, pop-off 140psi	1
2	F05778	1/4 NPT to 3/8 Air Line	1
3	F05150	Fitting, Street Elbow 4-4	2
4	S40120	Extreme Air pressure switch	1
5	F05059	Fitting, Pipe Cross 4-4-S	1
6	V02220	Valve, check one way	1
7	B36003	50amp Circuit Breaker	1
8	B15037	Bracket, Compressor	1
9	S22050	Cole Hersee HD Solenoid	1
10	C21020	Compressor, Air	1

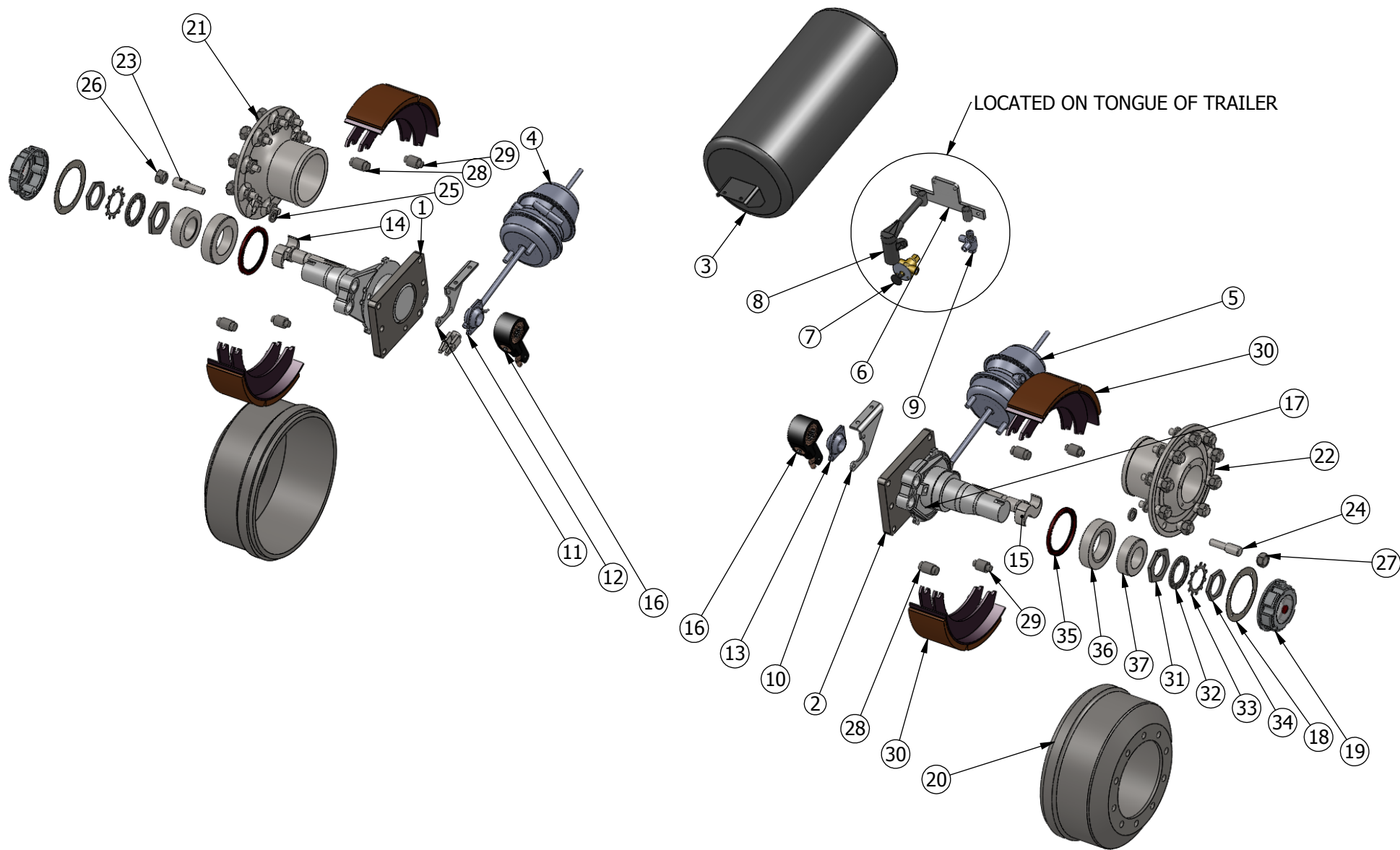

ITEM NO.	PART NUMBER	DESCRIPTION	QTY.
1	S26945	Spindle, Air LH	1
2	S26953	Spindle Air RH	1
3	T01041	Tank, Air large	1
4	C32095	Can, Air 30/30 w/Long Rod	1
5	C32095	Can, Air 30/30 w/Long Rod	1
6	B12210	Bracket, Gladhand	1
7	V02008	Valve, Cab control	1
8	V02018	Valve, hand control	1
9	V02038	Valve, check 2-way	1
10	B15096	Bracket, S-Cam Bushing RH	1
11	B15097	Bracket, S-Cam Bushing LH	1
12	B15902	Bushing,S-Cam RH	1
13	B15903	Bushing S-Cam LH	1
14	C44015	Cam, Air brake LH	1
15	C44020	Cam, Air brake RH	1
16	A11030	Adjuster, Auto Slack 10 spline	2
17	Y01043	Yoke Midland Straight	2
18	G01010	Gasket, Hub acp 16-1/2x5	2
19	C06071	Cap, Hub 16-1/2 x 5	2
20	D08000	Drum Only, Air Brake 16-1/2x5	2
21	H09974	Hub Only, Air Brake LH	1
22	H09975	Hub Only, Air Brake RH	1
23	S37083	Stud, Air Brake 1-1/8-16 LH	10
24	S37082	Stud, Air Brake 1-1/8-16 RH	10
25	W01290	Washer, Thick Drum Assembly	20
26	N04058	Nut, Lug 1-1/8-16 LH	10
27	N04059	Nut, Lug 1-1/8-16 RH	10
28	P04002-1	Pin, Air Brake Large	4
29	P04002-2	Pin, Air Brake Small	4
30	S15030	Shoe, Air Brake 16-1/2x5	4
31	N04201	Nut, Hub Inner	2
32	W01202	Washer, Locking Air Brake	2
33	W01201	Washer, Lock Spindle Tab	2
34	N04202	Nut, Hub Outer	2
35	S05130	Seal, Grease Hub	2
36	B07140	Bearing, Inner	2
37	B07085	Bearing, Outter	2



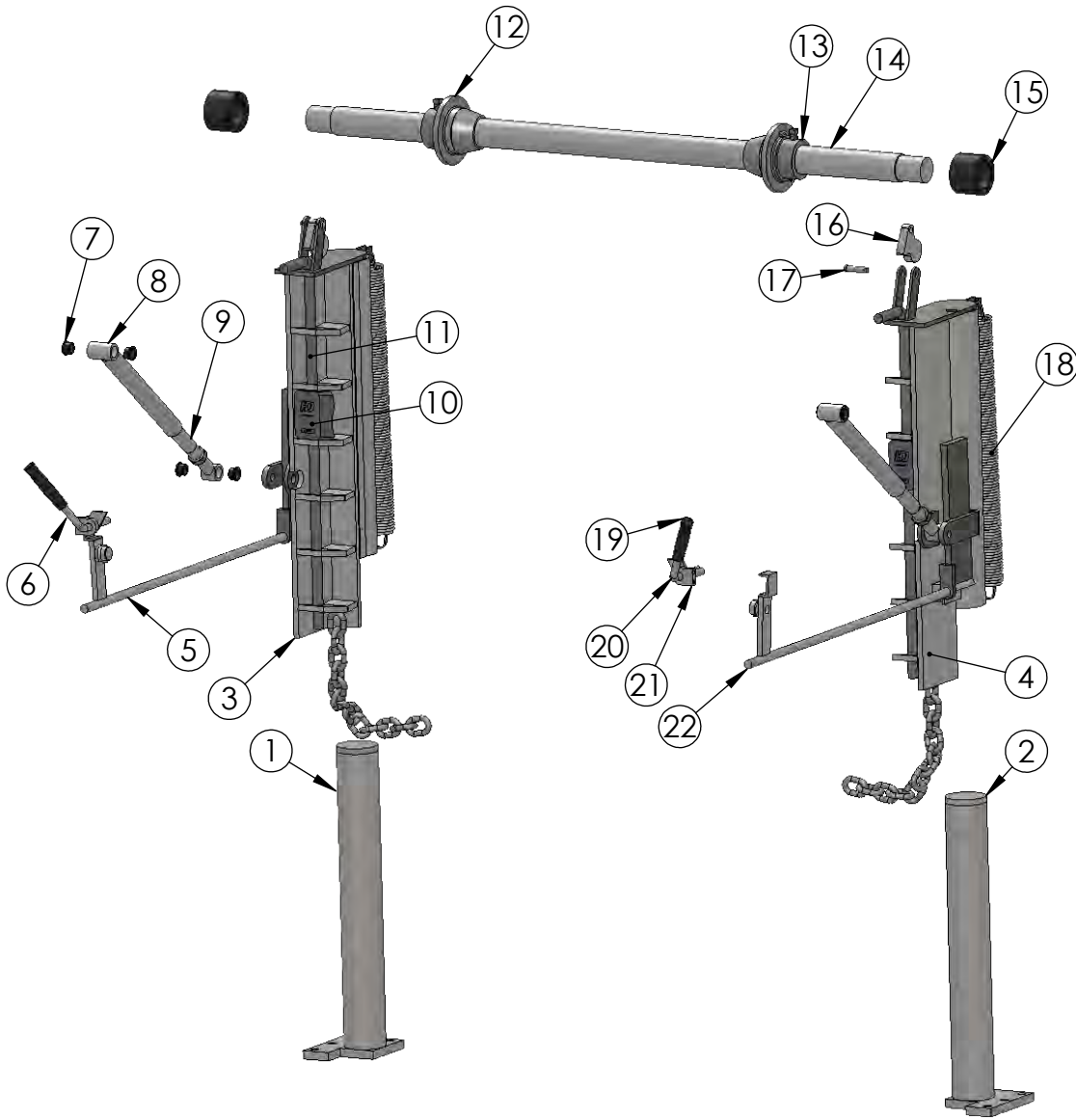

ITEM NO.	PART NUMBER	DESCRIPTION	QTY.
1	C32040	Mandrel Cylinder LH D3188	1
2	C32025	Mandrel Cylinder RH D3189	1
3	R01925	Rack, Mandrel LH	1
4	R01945	Rack, Mandrel RH	1
5	L08015A	Lock Assy, Mandrel Rack LH	1
6	H02045A	Handle, Mandrel Lock LH	1
7	B07365	Bearing, I-Glide 3/4x1x5/8	8
8	S30021	Stabilizer, Outside	2
9	S30005	Stabilizer, Inner	2
10	B22045	Block, Mandrel Bearing	2
11	P06035	Pin, Mandrel Locking	2
12	C25020	4" Aluminum Cone	2
13	C20015	Collar, 2-1/2" w/ studs	2
14	S43115	Shaft, 2-1/2" Mandrel	1
15	B07075	Bearing, Nylatron Mandrel	2
16	P04020	Pawl, Mandrel Locking Pin	2
17	P06095	Pin, 1/2 x 2	2
18	S28030	Spring, Mandrel Return	2
19	G07010	Handle, Rubber Flapper lock	2
20	H02050A	Handle, Mandrel Lock RH	1
21	B15130	Bracket, Mandrel Lock Handle	2
22	L08020A	Lock Assy, Mandrel Rack RH	1



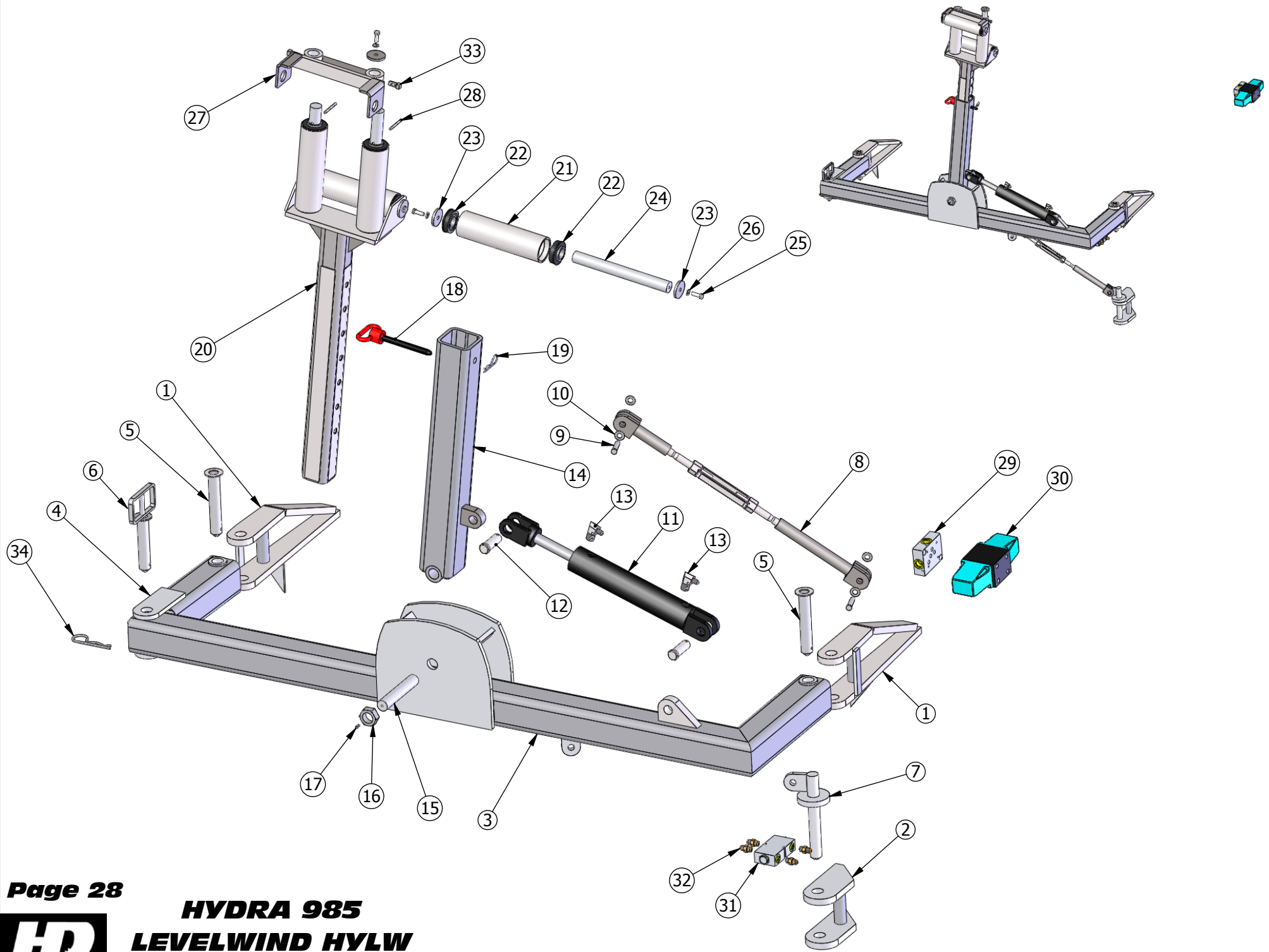

ITEM NO.	PART NUMBER	DESCRIPTION	QTY.
1	B15943	Bracket, Levelwind Std Fenders	1
2	B15230	Bracket, levelwind Lower	1
3	B15996	Levelwind Arm Standard	1
4	B15997	Levelwind Short Arm	1
5	P06029	Pin, Levelwind Pivot	2
6	P06042	Pin, Levelwind	1
7	P06830	Pin Lower Pivot	1
8	T15905A	Turnbuckle Assembly	1
9	P06095	Pin, 1/2 x 2	2
10	W01005	Washer Flat SAE 1/2	4
11	C32020	Cylinder, Levelwind	1
12	P06073	Pin, 1x2-3/4	2
13	F05360	Fitting, 6-8 90° NPT	2
14	S17000	Sleeve, Levelwind	1
15	P06156	Pin, Levelwind Pivot	1
16	N04097	Nut Hex Jam 1-1/4-12	2
17	F05630	Fitting, 1/4-28 Zerk	1
18	P06027	Pin, 5/8 x 6 w/Handle	1
19	C17020	Clip, Hitch #20	1
20	A08089	Arm, Levelwind	1
21	R20044	Roller, Painted Steel	4
22	B07110	Bearing, Roller	8
23	C06041	Cap, End	5
24	S43129	Shaft, Roller	2
25	B11342	Bolt Hx head 3/8-16x1	5
26	W01545	Washer, Split Lock 3/8"	5
27	B15897	Bracket, Swing-away Fairlead	1
28	P06193	Pin, Roll 1/4 x 2-1/2	2
29	P09170	Plate, Sub	1
30	V02145	Valve Capstan/Levelwind	1
31	V02075	Valve, Loadlock	1
32	F05755	Fitting, 6-6 Str SAE	4
33	S04475	Screw, Set Sq Head 1/2 x 1	2
34	C17015	Clip, Hitch Pin 5"	1



**If items look different from the parts breakdown please call for assistance. (541)354-1001**

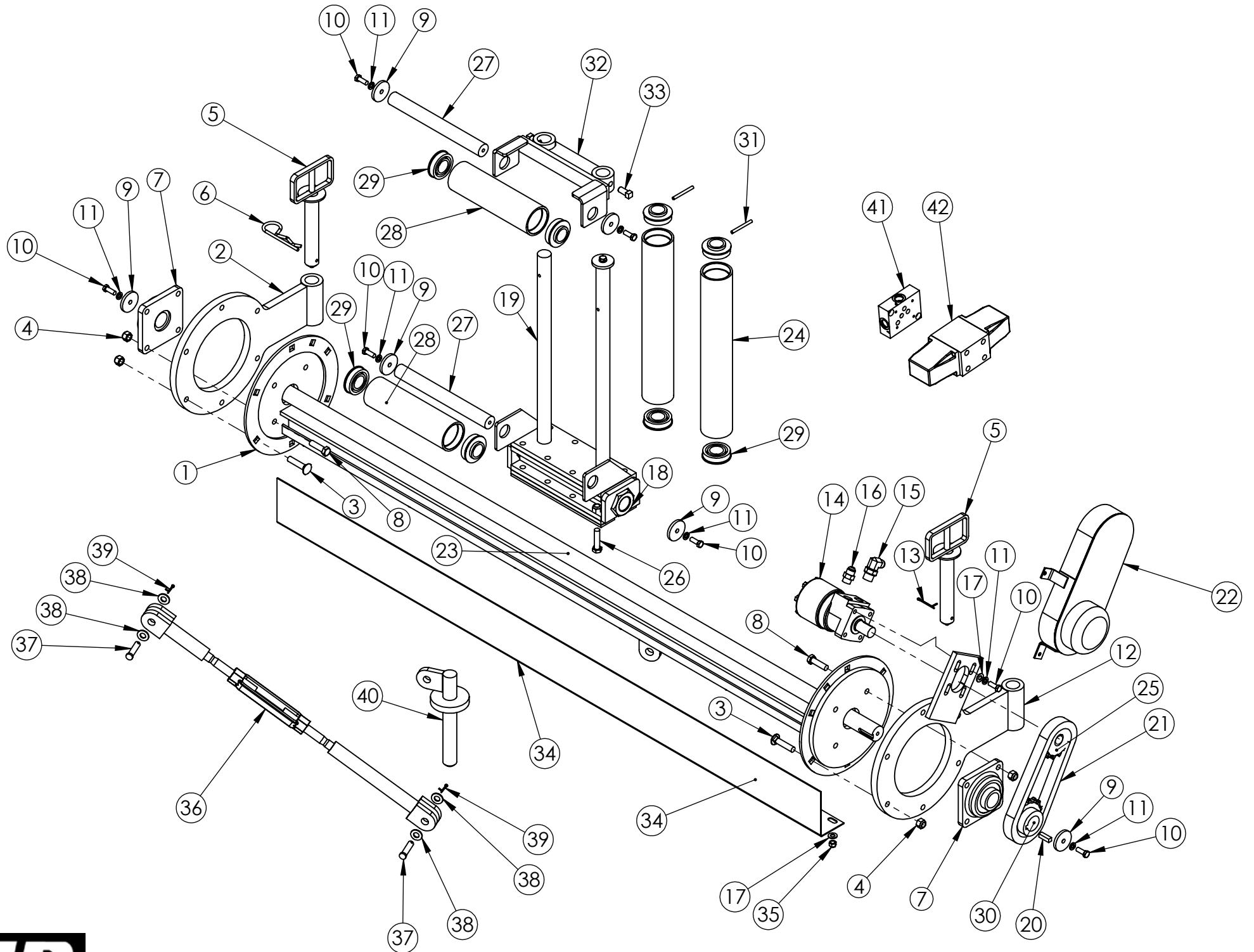

ITEM NO.	PART NUMBER	DESCRIPTION	QTY.
1	F09060	Frame L/W Acme Screw	1
2	P09080	Plate L/W End	1
3	B11155	Bolt, Carriage 1/2"-13 x 2-1/4"	12
4	N04555	Nut, Hx Nylock® 1/2"-13	36
5	P06155	Pin, Level Wind 7"	2
6	C17015	Clip, Hitch Pin 5"	1
7	B07130	Bearing	2
8	B11364	Bolt, Hx Head 1/2"-13 x 1-3/4"	15
9	C06041	Cap, End	7
10	B11342	Bolt, Hx Head 3/8"-16 x 1"	11
11	W01545	Washer, Split Lock 3/8"zinc	11
12	P09078	Plate L/W end w/Motor	1
13	P06925	Pin, Cotter 1/8" x 2" Z	1
14	M08050	Motor, Hydraulic Drive	1
15	F05015	Fitting, 8 JIC to -8 SAE 90°	1
16	F05315	Fitting,8-8 Str SAE	1
17	W01002	Washer, Flat SAE 3/8"zinc	10
18	N04905	Nut, Acme 1-1/2"-6	2
19	C37904A	Carrier HYLW2	1
20	K01028	Key, Drive LW2	1
21	C10155	Chain #60	1
22	G09045	Guard, Chain	1
23	S04115	Screw, Acme Levelwind	1
24	R20005	Roller, Vertical	2
25	S29080	Sprocket, 60B14 1"Bore	1
26	B11446	Bolt, Hx Head 1/2"-13 x 2" Z8	8
27	S43129	Shaft, Roller	2
28	R20044	Roller, Horizontal	2
29	B07110	Bearing, Roller	8
30	S29075	Sprocket, 60B14 1-1/2"Bore	1
31	P06193	Pin, Roll 1/4" x 2-1/2"	2
32	B15897	Bracket, Swing-away Fairlead	1
33	S04475	Screw, Set Sq Head 1/2" x 1"	2
34	G09000	Guard, HYLW3	1
35	N04545	Nut, Hx Nylock® 3/8"-16	6
36	T15905A	Turnbuckle Assembly	1
37	P06095	Pin, 1/2 x 2	2
38	W01005	Washer, Flat SAE 1/2"zinc	4
39	P06933	Pin, Cotter 1/8" x "1 Z	2
40	P06830	Pin Lower Pivot	1
41	P09170	Plate, Sub	1
42	V02145	Valve Capstan/Levelwind	1



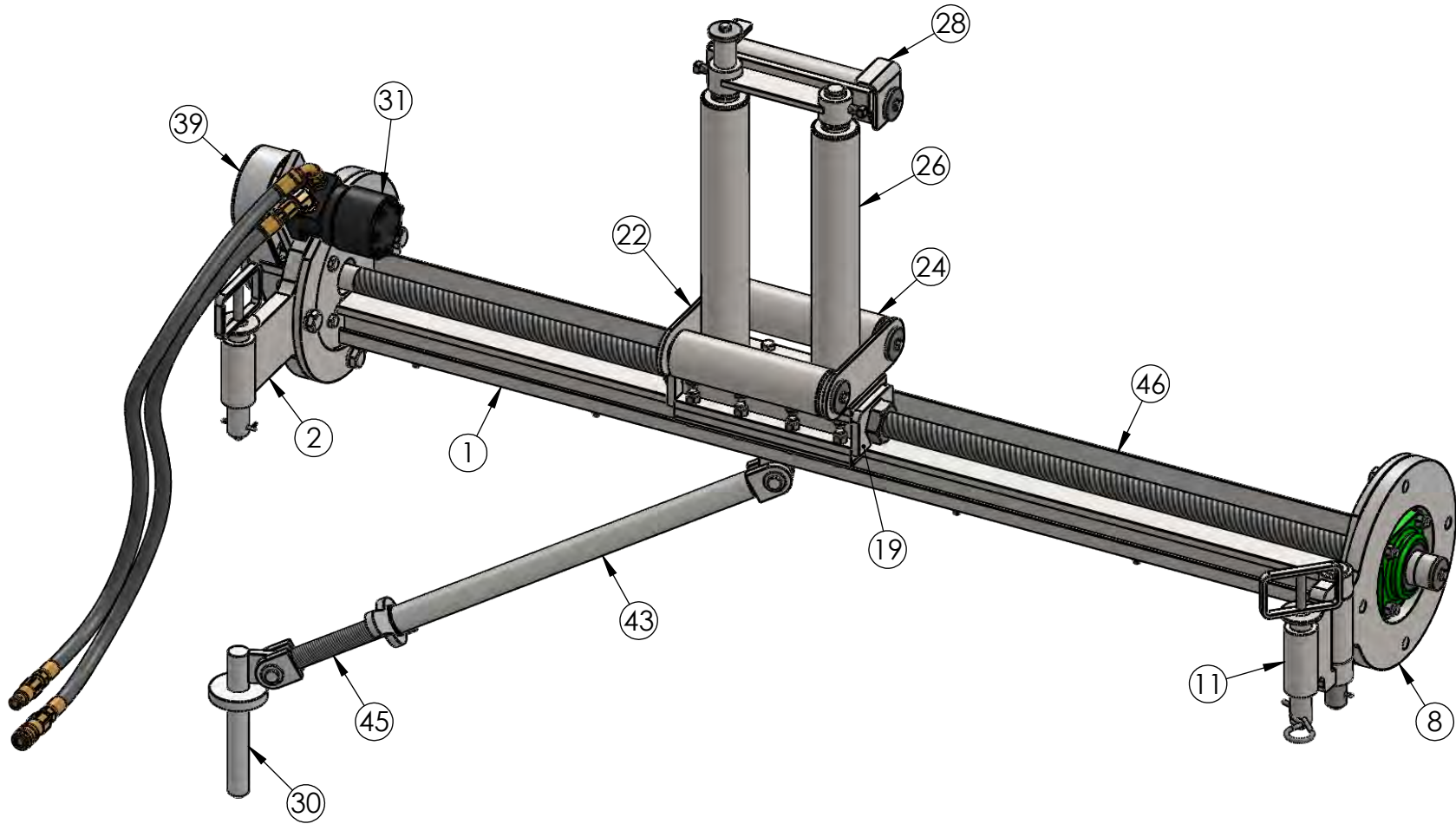

ITEM NO.	PART NUMBER	DESCRIPTION	QTY.
1	F09061	Frame Screw Levelwind	1
2	P09079	Plate Motor Mounting	1
3	B11382	Bolt, Hx Head 3/4"-16 x 1-3/4"	8
4	W01585	Washer, Split Lock 3/4"zinc	8
5	B07130	Bearing	2
6	B11364	Bolt, Hx Head 1/2"-13 x 1-3/4"	16
7	N04555	Nut, Hx Nylock® 1/2"-13	24
8	P09081	Plate Swivel End	1
9	P06043	Pin	1
10	P06948	Pin, Cotter 3/16x2 Z	2
11	S41121	Swivel Link Levelwind LW3	1
12	P06155	Pin, Level Wind 7"	2
13	C17015	Clip, Hitch Pin 5"	1
14	B11437	Bolt, Hx Head 3/8"-16 x 1" Z8	13
15	W01545	Washer, Split Lock 3/8"zinc	13
16	C06041	Cap, End	9
17	S04115	Screw, Acme Levelwind	1
18	N04905A	Nut, Acme 1-1/2-4	2
19	C37906	Carrige Screw Levelwind LW3	1
20	B11366	Bolt, Hx Head 1/2"-13 x 2"	8
21	S24032	Spacer, Levelwind Shaft	1
22	F09111	Fairlead Levelwind LW3	1
23	S43129	Shaft, Roller	3
24	R20044	Roller, Horizontal	3
25	B07110	Bearing, Roller	10
26	R20005	Roller, Vertical	2
27	P06193	Pin, Roll 1/4" x 2-1/2"	2
28	B15897	Bracket, Swing-away Fairlead	1
29	S04475	Screw, Set Sq Head 1/2" x 1"	2
30	P06830	Pin Lower Pivot	1
31	M08050	Motor, Hydraulic Drive	1
32	F05555	Fitting, 8 JIC to -10 SAE 90°	1
33	F05270	Fitting, 8-10 Str SAE	1
34	W01002	Washer, Flat SAE 3/8"zinc	14
35	S29080	Sprocket, 60B14 1" Bore	1
36	S29075	Sprocket, 60B14 1-1/2" Bore	1
37	K01028	Key, Drive	1
38	C10155	Chain #60	1
39	G09045	Guard, Chain	1
40	B11323	Bolt, Hx Head 1/4"-20 x 3/4"	3
41	W01525	Washer, Split Lock 1/4"zinc	3
42	W01205	Washer, Flat SAE 1/4"zinc	3
43	S30050	Stabilizer Levelwind Upper LW3	1
44	P06933	Pin, Cotter 1/8" x "1 Z	2
45	S30051	Stabilizer Levelwind Lower LW3	1
46	G09013	Guard, HYLW3	1
47	N04545	Nut, Hx Nylock® 3/8"-16	5
48	P06077	Pin, 5/8 x 2 plated	2
49	W01053	Washer, Flat SAE 5/8"zinc	4
50	F05013	Fitting Hs -8 F JIC 90°	1
51	F05028	Fitting, Hs -8 F JIC	1
52	F05325	Fitting -8 Hs - 1/2 Mnpt	2
53	H07173-1	Hose 1/2 -1wire 38"	1
54	H07173-2	Hose 1/2 -1wire 40"	1
55	C28061	Coupler, F quick 1/2 NPT	1
56	C28062	Coupler, M quick 1/2 NPT	1



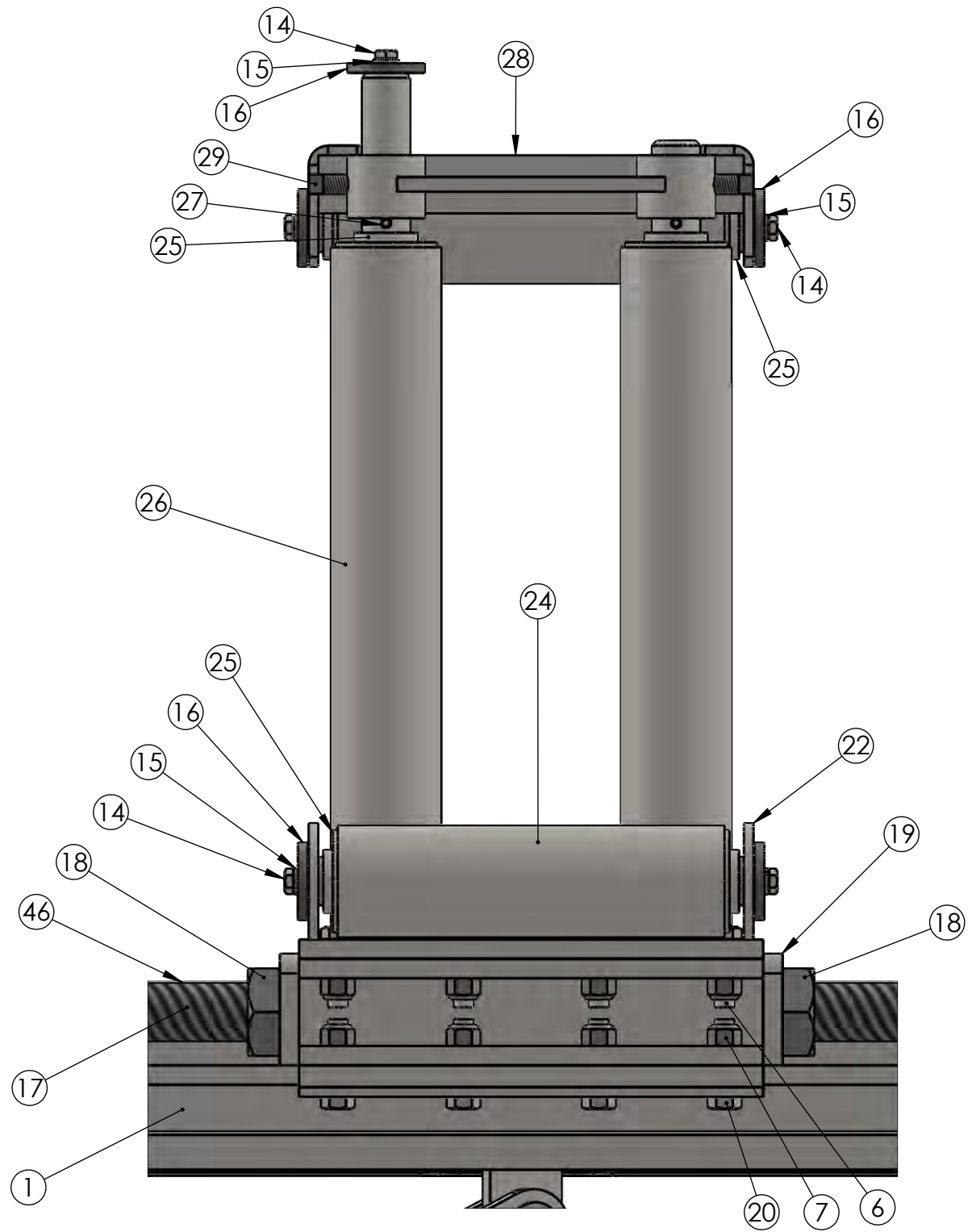

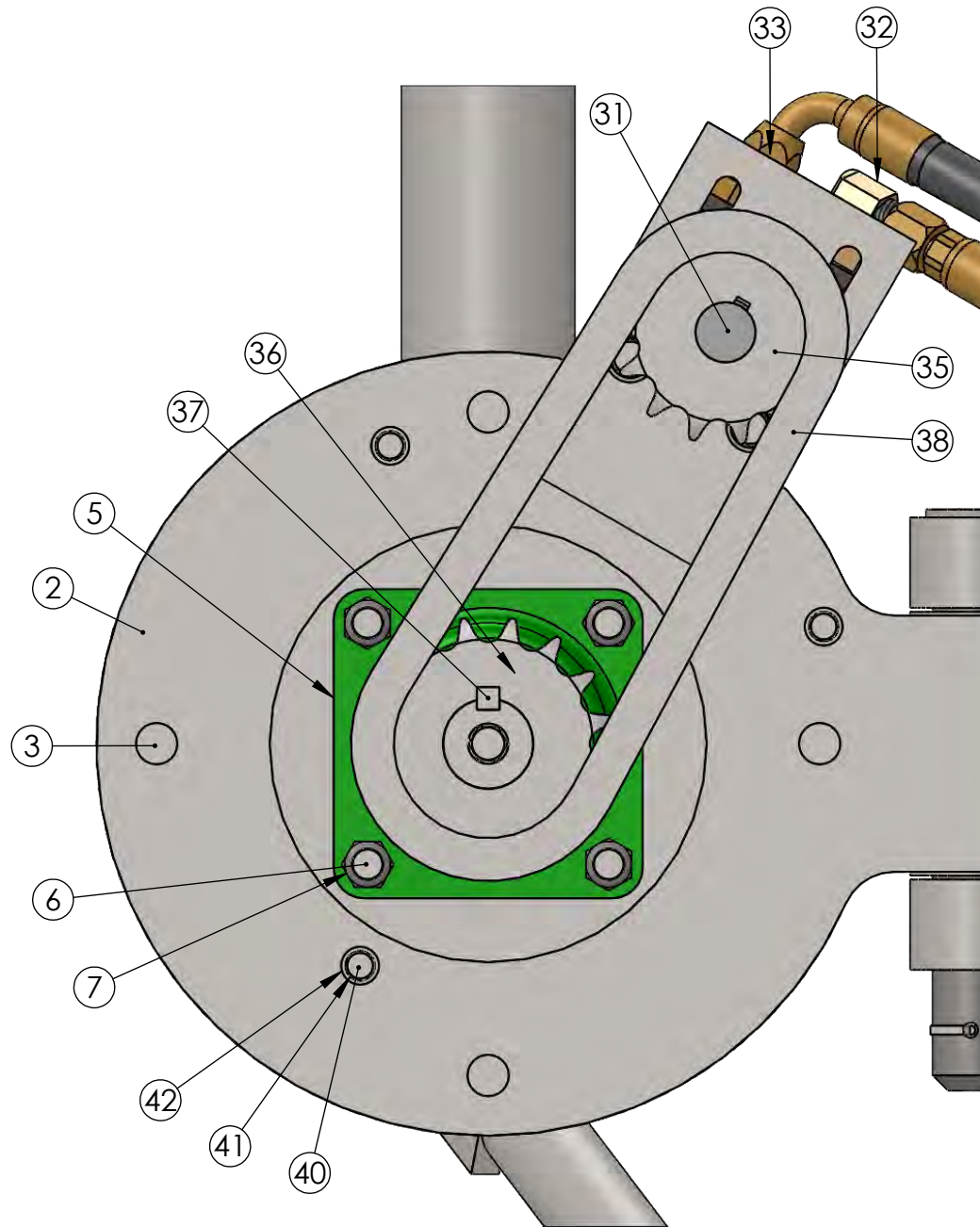

#40~#42 guard bolts



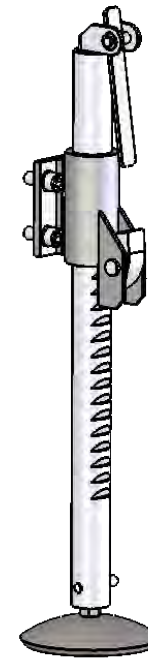
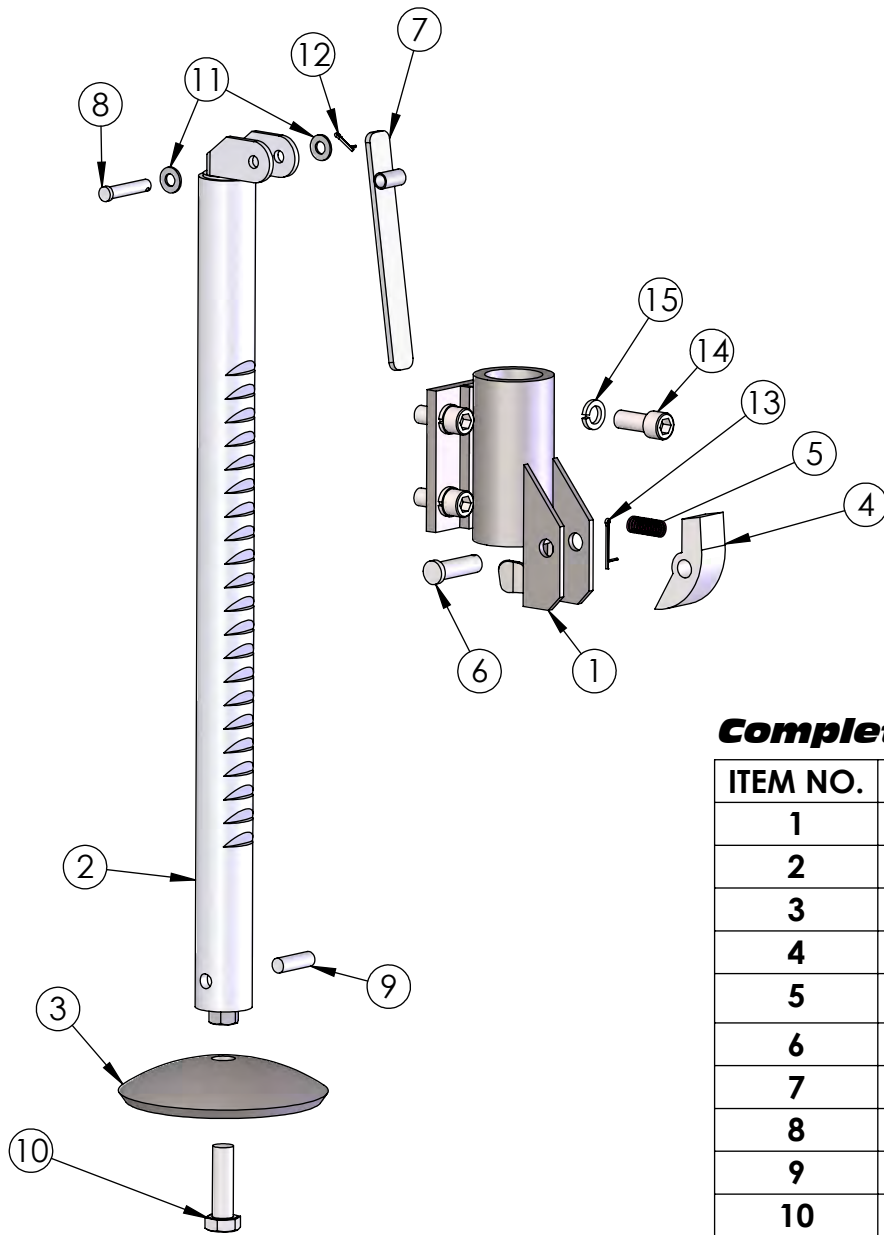

**Complete Assembly Part Number: J01015A**

ITEM NO.	PART NUMBER	DESCRIPTION	QTY.
1	S17930	Sleeve, Jackstand bolt on LH	1
2	J01010	Jackstand, 985/6500	1
3	P01020	Pad	1
4	P04005	Pawl	1
5	S28075	Spring, Jackstand / EPO	1
6	P06100	3/4" X 2-1/2" PIN	1
7	H02015	Handle, Jackstand	1
8	P06105	1/2" X 2-1/2" PIN	1
9	S37010	5/8"-11 STUD	1
10	B11060	Bolt, Hx Head 7/8"-9 x 3" Z8	1
11	W01005	Washer, Flat SAE 1/2"zinc	2
12	P06933	Pin, Cotter 1/8" x "1 Z	1
13	P06925	Pin, Cotter 1/8" x 2" Z	1
14	S04245	Screw, SHCS 3/4"-16 x 1-3/4"	4
15	W01585	Washer, Split Lock 3/4"zinc	4

***If items look different from the parts breakdown please call for assistance. (541)354-1001***

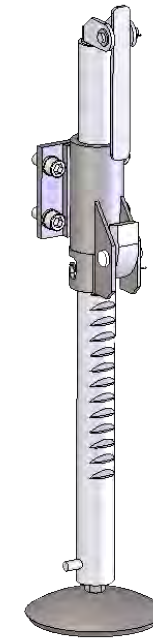
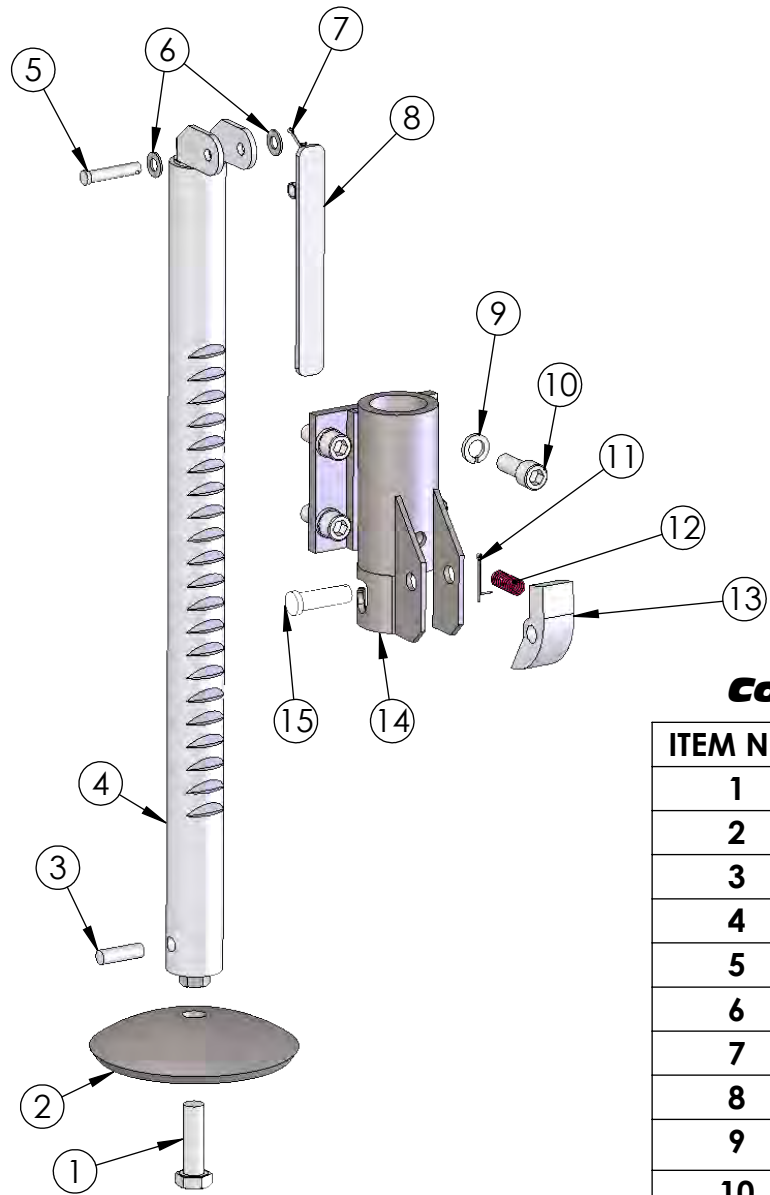

***Complete Assembly Part Number: J01016A***

ITEM NO.	PART NUMBER	DESCRIPTION	QTY.
1	B11060	Bolt, Hx Head 7/8"-9 x 3" Z8	1
2	P01020	Pad	1
3	S37010	5/8"-11 STUD	1
4	J01010	Jackstand, 985/6500	1
5	P06105	1/2" X 2-1/2" PIN	1
6	W01005	Washer, Flat SAE 1/2"zinc	2
7	P06933	Pin, Cotter 1/8" x "1 Z	1
8	H02015	Handle, Jackstand	1
9	W01585	Washer, Split Lock 3/4"zinc	4
10	S04245	Screw, SHCS 3/4"-16 x 1-3/4"	4
11	P06925	Pin, Cotter 1/8" x 2" Z	1
12	S28075	Spring, Jackstand / EPO	1
13	P04005	Pawl	1
14	S17935	Sleeve, Jackstand bolt on RH	1
15	P06100	3/4" X 2-1/2" PIN	1



***Jackstand, Bolt on Right Hand***

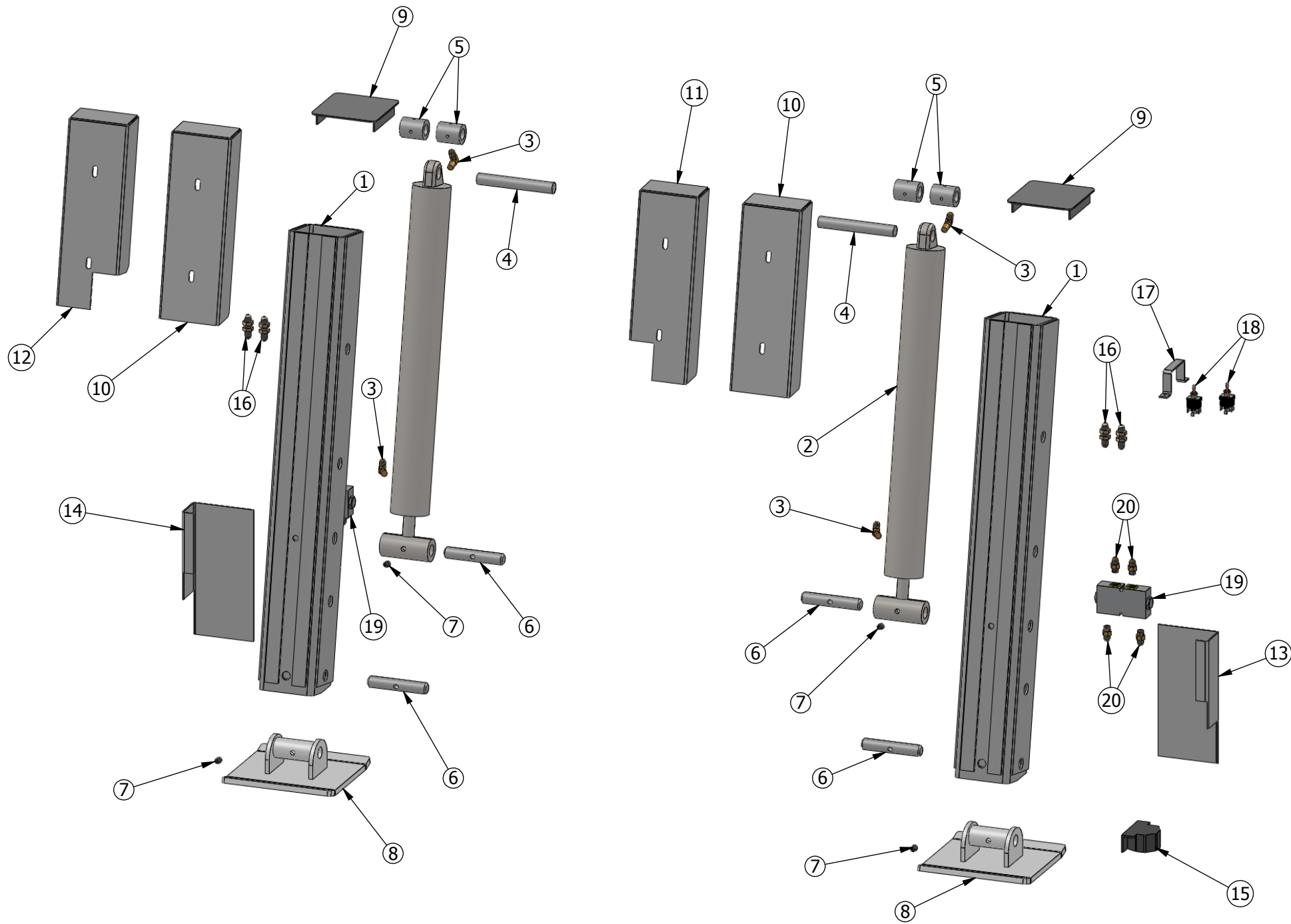

ITEM	PART NUMBER	DESCRIPTION	QTY.
1	J04005	Jack, Hydraulic Outriggers	2
2	C32015	Cylinder Outrigger	2
3	F05565	Fitting, 6-4 Elbow	4
4	P06200	Pin, Outrigger Cylinder Upper	2
5	C20040	Spacer, Outrigger Cylinder	4
6	P06165	Pin, Lower Outrigger	4
7	S04261	Screw, Set 1/2-13x1/2 CP	4
8	P01035	Pad, Hydraulic Outrigger	2
9	C29013	Cover, Outrigger Top	2
10	C29055	Cover, Outrigger Hoses	2
11	C29058	Cover, Outrigger Hoses RH	1
12	C29056	Cover, Outrigger Hoses LH	1
13	G09015	Guard, Fender Wiring	1
14	G09020	Guard, Fender Wiring	1
15	A03005	Alarm, motion	1
16	F05170	Fitting, -6 JIC bulkhead	4
17	G09021	Guard, Toggle Switch	1
18	S40150	Switch, DP/DT Momentary	2
19	V02075	Valve, Loadlock	2
20	F05755	Fitting, 6-6 Str SAE	8



**If items look different from the parts breakdown please call for assistance. (541)354-1001**

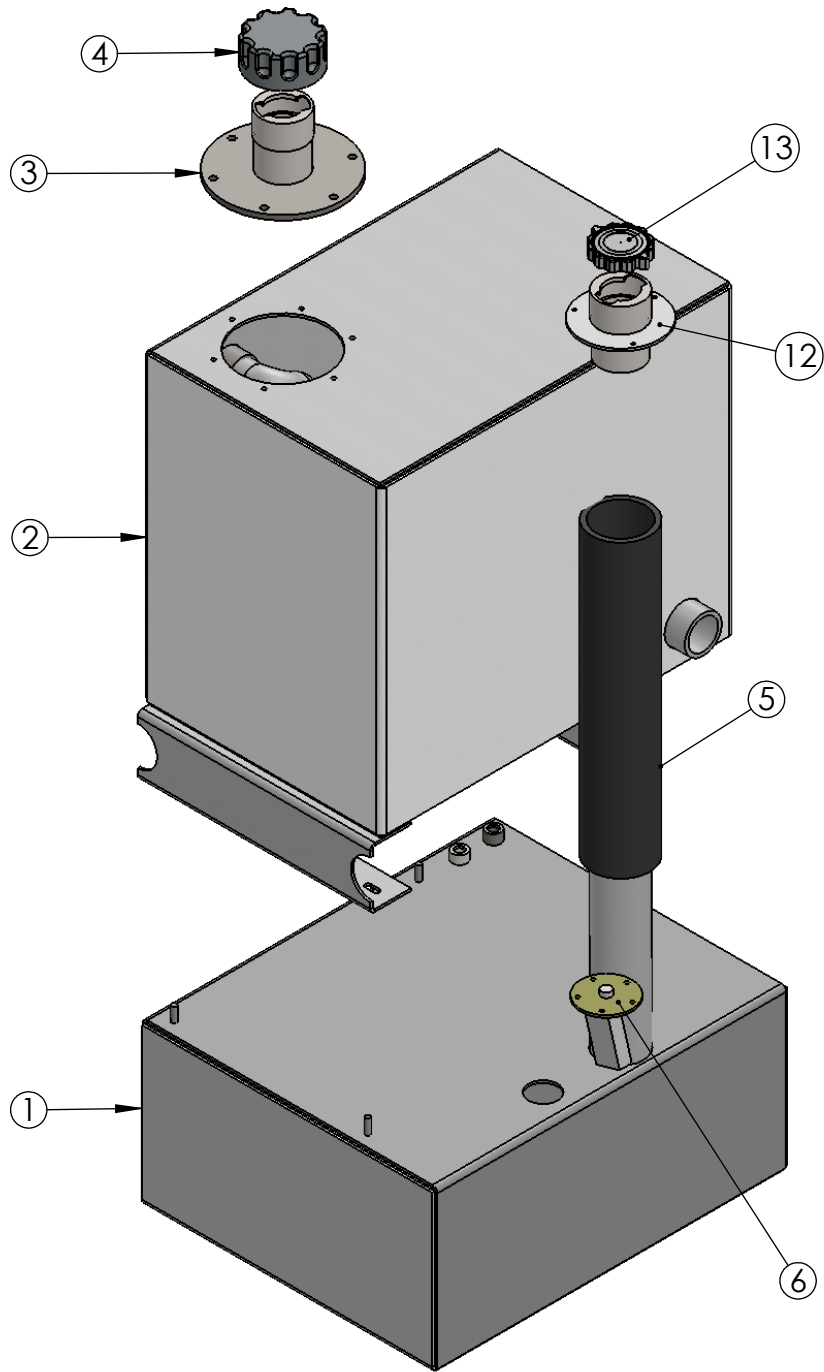

ITEM NO.	PART NUMBER	DESCRIPTION	QTY.
1	T01950	Tank, Fuel	1
2	T01951	Tank, Hydraulic	1
3	N07002	Neck, Hydraulic fill	1
4	C06155A	Cap, Hydraulic	1
5	H07000	Hose, Fuel Fill	1
6	S46015	Sender, Fuel Level	1
7	N02005	1-1/4" Closed Nipple	2
8	V02001	Valve, Ball 1-1/4" NPT	1
9	F04021	Filter Head	1
10	F04020	Filter 10 micron	1
11	G02010	Gauge, Suction	1
12	N07001	Nozzle, Fuel Fill	1
13	C06205	Cap, Fuel	1

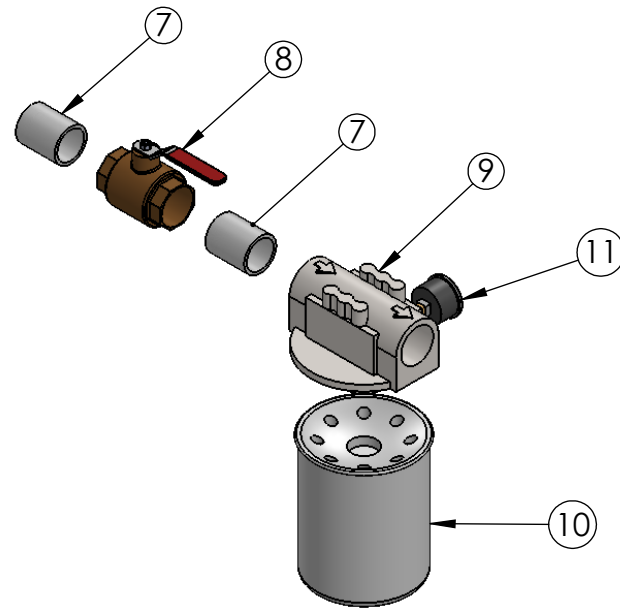

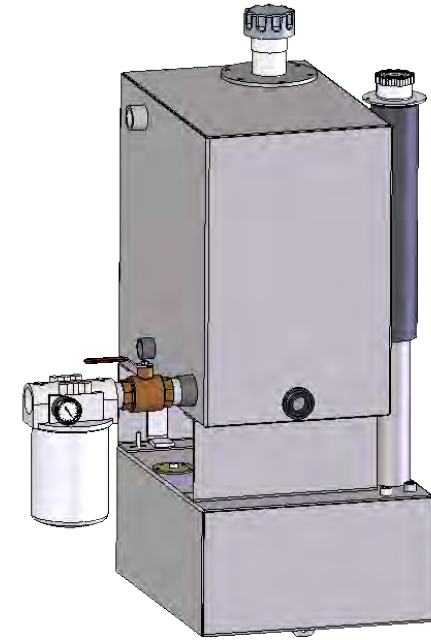
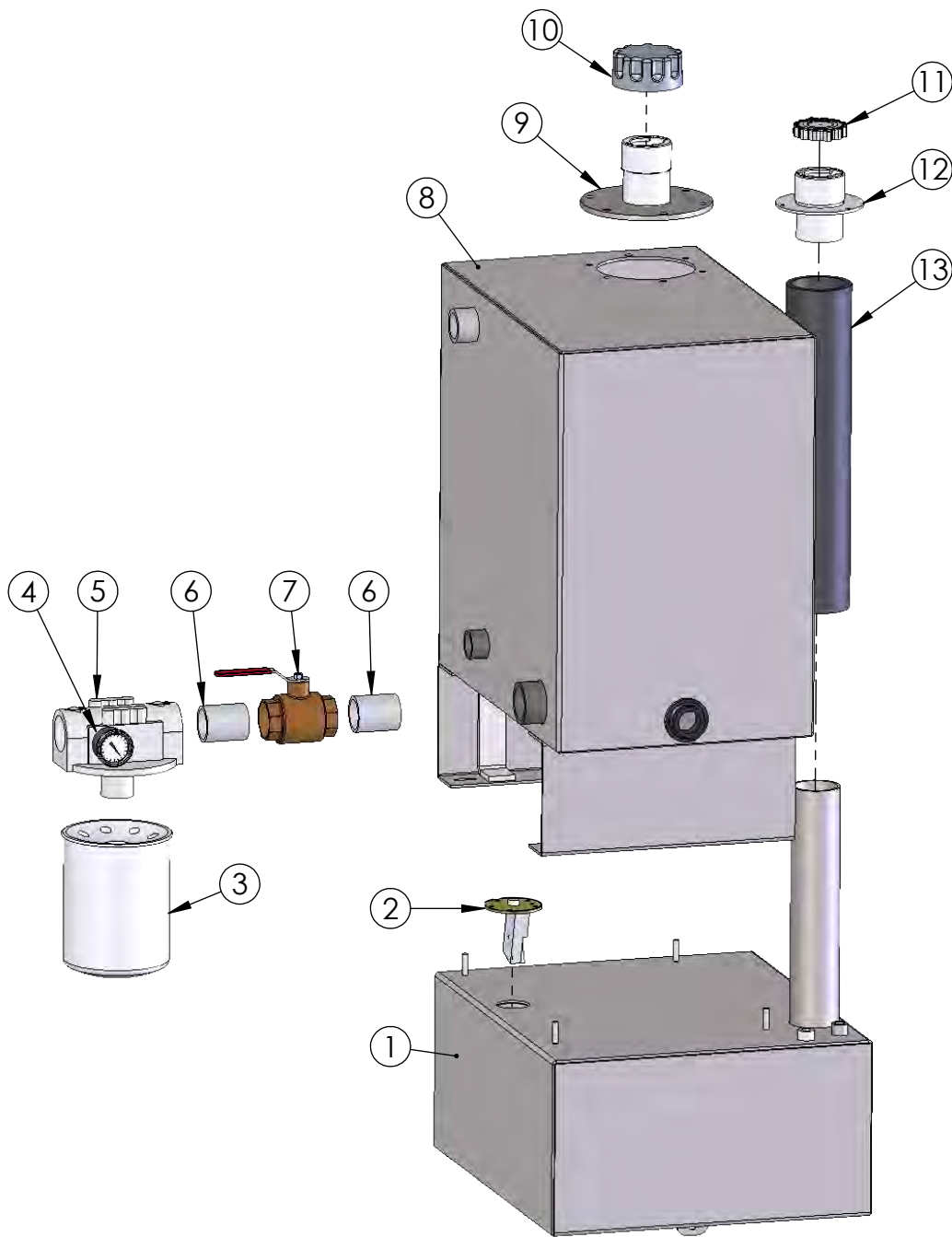

ITEM NO.	PART NUMBER	DESCRIPTION	QTY.
1	T01952	Tank, Fuel	1
2	S46015	Sender, Fuel Level	1
3	F04020	Filter 10 micron	1
4	G02010	Gauge, Suction	1
5	F04021	Filter Head	1
6	N02005	1-1/4" Closed Nipple	2
7	V02001	Valve, Ball 1-1/4" NPT	1
8	T01953	Tank, Hydraulic	1
9	N07002	Neck, Hydraulic fill	1
10	C06155A	Cap, Hydraulic	1
11	C06205	Cap, Fuel	1
12	N07001	Nozzle, Fuel Fill	1
13	H07000	Hose, Fuel Fill	1

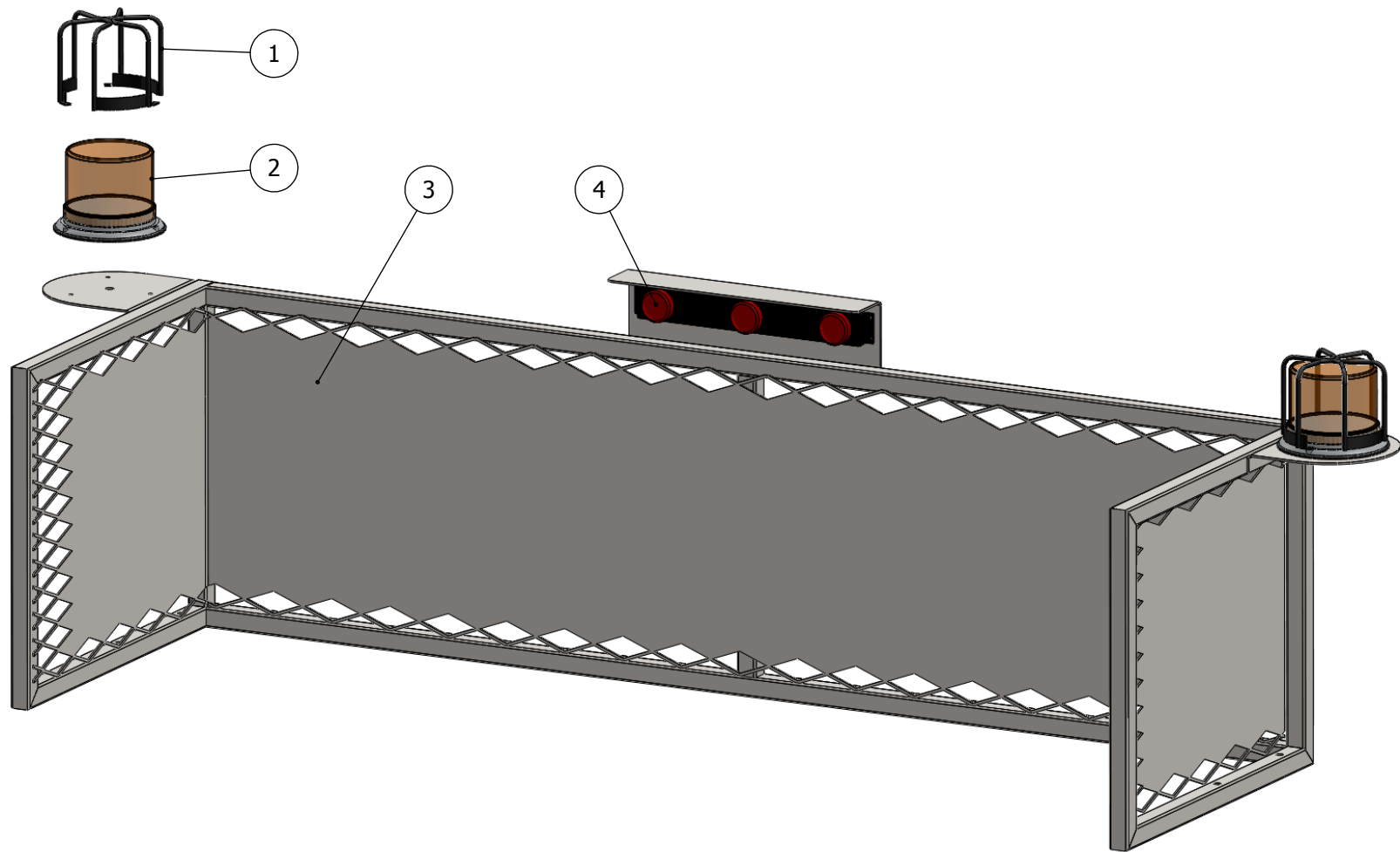

ITEM NO.	PART NUMBER	DESCRIPTION	QTY.
1	G09019	Guard, strobe	2
2	L04105	Light Strobe	2
3	S08040	Screen	1
4	L04060	Light Bar, 3 light	1

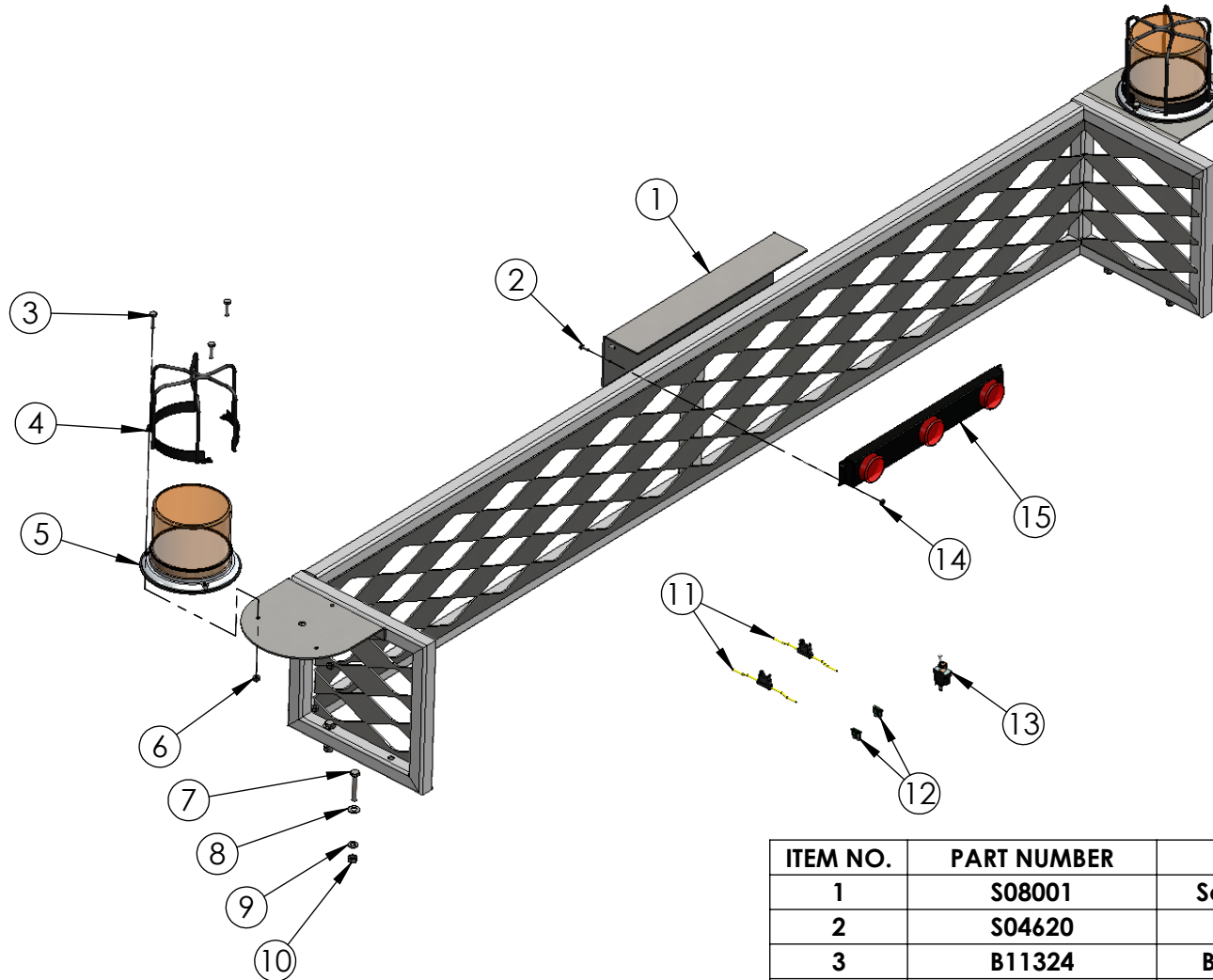

ITEM NO.	PART NUMBER	DESCRIPTION	QTY.
1	S08001	Screen, HP6500 Power Unit	1
2	S04620	Screw, #10-32 x 1/2	4
3	B11324	Bolt, Hx Head 1/4"-20 x 1"	6
4	G09019	Guard, strobe	2
5	L04105	Light, Amber Strobe	2
6	N04525	Nut, Hx Nylock® 1/4"-28	6
7	B11004	Bolt, Hx Head 3/8"-16 x 2"	4
8	W01002	Washer, Flat SAE 3/8"zinc	4
9	W01545	Washer, Split Lock 3/8"zinc	4
10	N04108	Nut, Hx 3/8"-16	4
11	H10002	Holder, Fuse	2
12	F01002	Fuse, 30amp	2
13	S40035	Switch, SP/ST Toggle	1
14	N04203	Nut Hex 10-32	4
15	L04060	Light Bar, 3 light	1



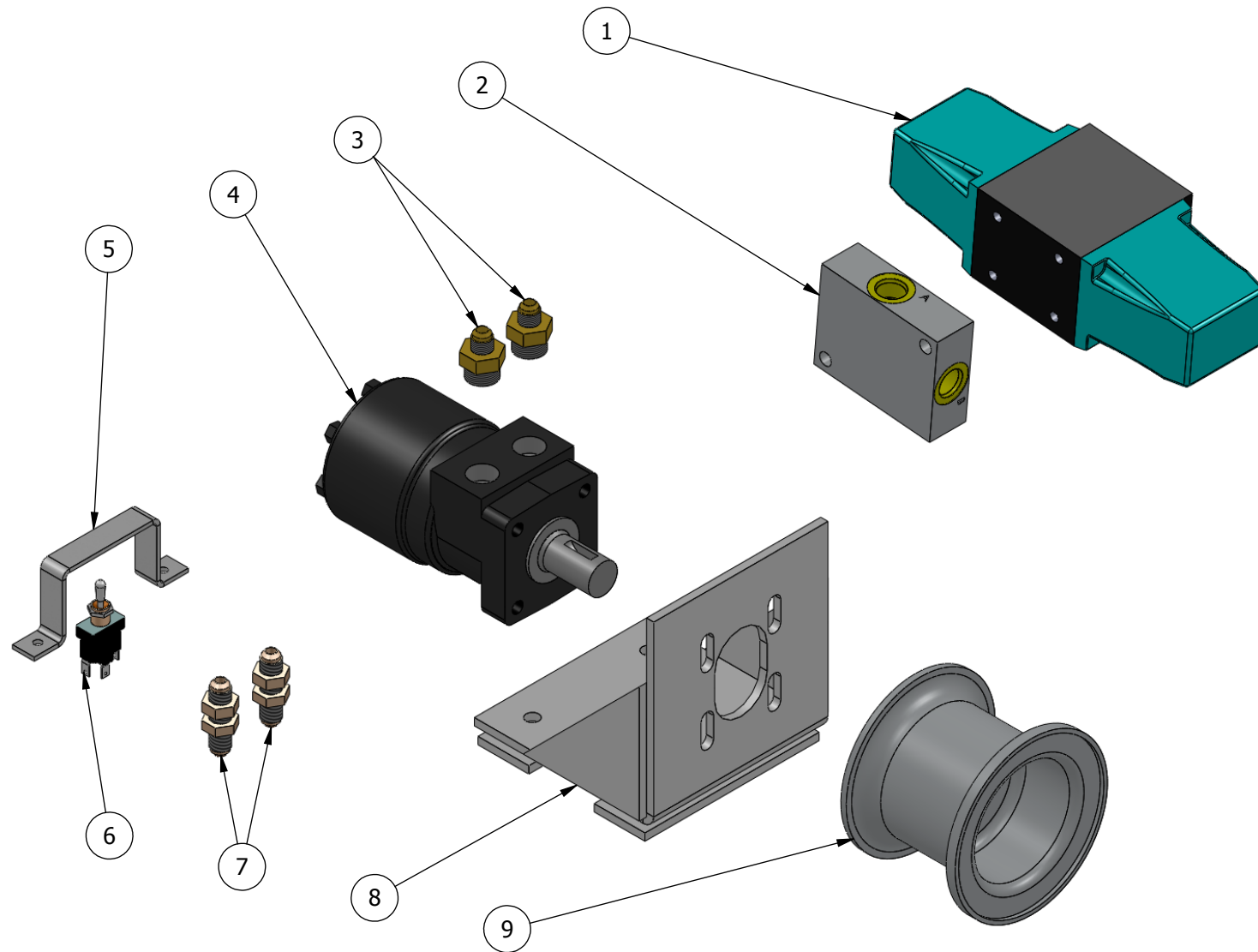

ITEM	PART NUMBER	DESCRIPTION	QTY.
1	V02145	Valve Capstan/Levelwind	1
2	P09170	Plate, Sub	1
3	F05762	Fitting, 6-10 Str SAE	2
4	M08050	Motor, Hydraulic Drive	1
5	G09021	Guard, Toggle Switch	1
6	S40153	Switch, SP/DT Maintained w/center	1
7	F05170	Fitting, -6 JIC bulkhead	2
8	B15998	Bracket, Capstan Mount	1
9	C38905A	Cathead, Capstan	1

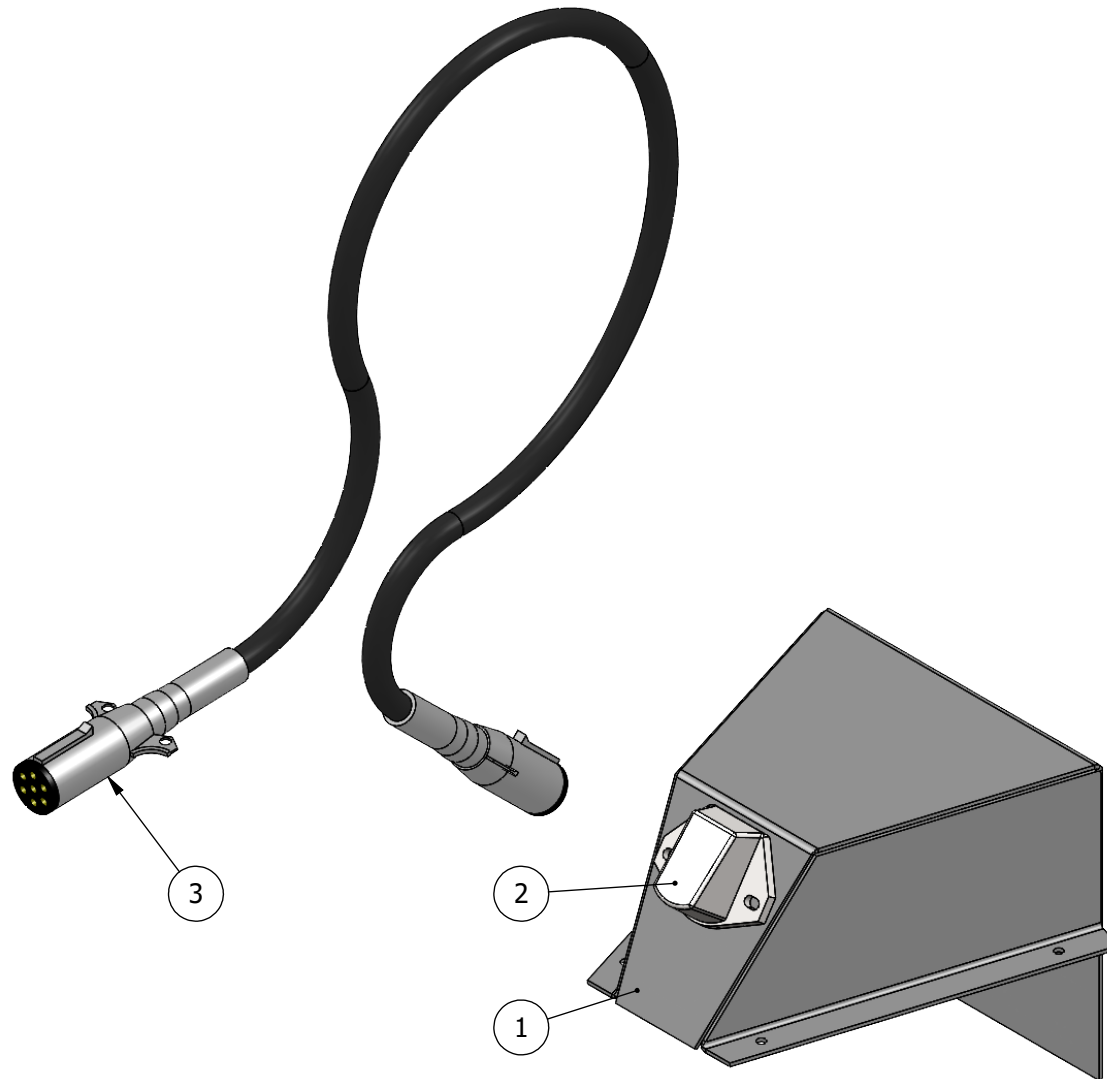

ITEM NO.	PART NUMBER	DESCRIPTION	QTY.
1	H05070	Hood, Electrical 7 wire	1
2	S21035	Socket 7-wire Pollak	1
3	C02111	Cable Whip 7 Wire x 36"	1

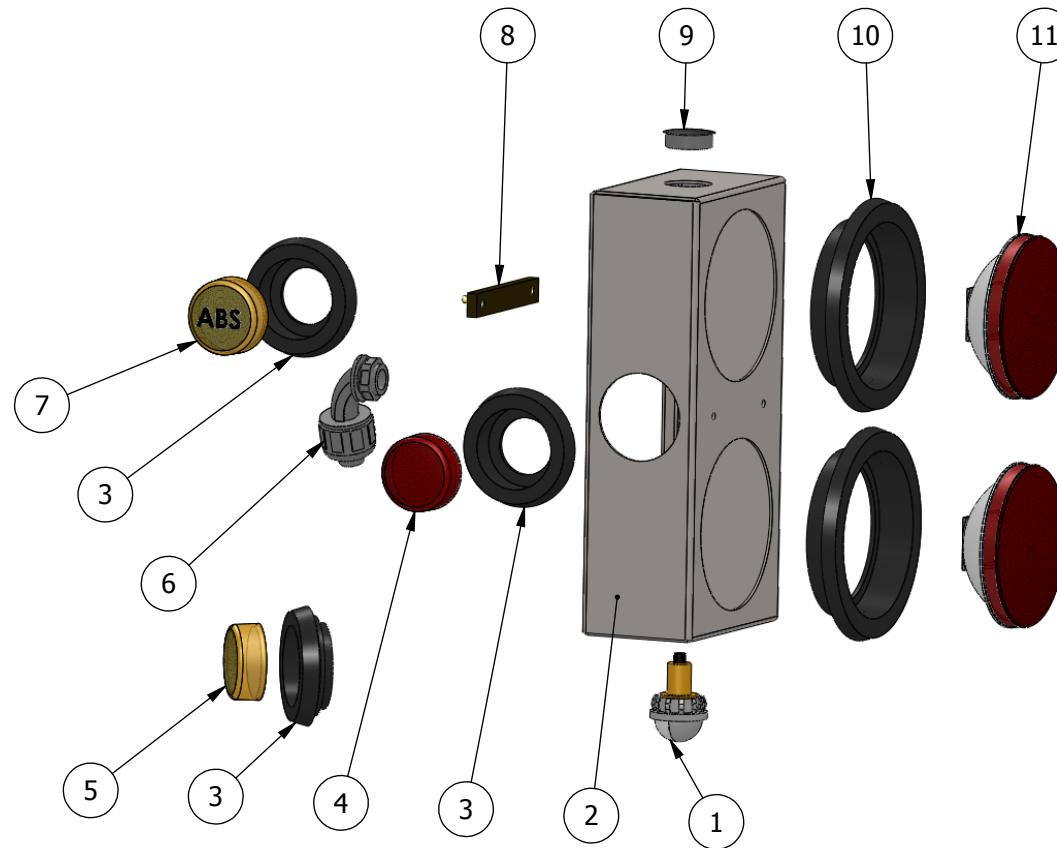

**NOTE:** QUANTITIES ARE PER TRAILER

ITEM NO.	PART NUMBER	DESCRIPTION	QTY.
1	L04080	Light, License	1
2	B13048	Box, light Vertical	2
3	G08005	Grommet 2" Light	5
4	L04070	Light, 2" Red	2
5	L04035	Light, 2" Amber	2
6	C26165	Liquidtite 90	2
7	L04047	Light, ABS 2" Amber	1
8	B22050	Block, 4 Pole Terminal Strip	2
9	P10175	Plug, Plastic Button 1-1/4"	3
10	G08010	Grommet, 4" Tail/Stop/Turn	4
11	L04030	Light, 4" Tail Stop Turn	4

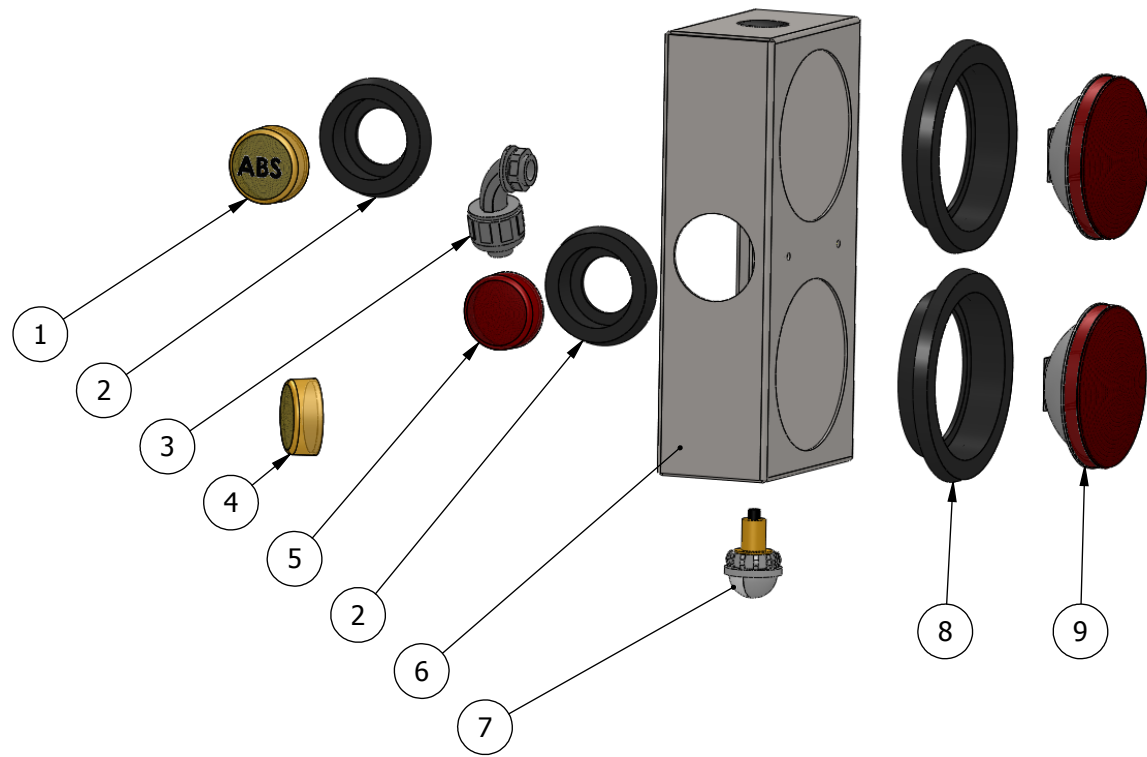

**NOTE:** QUANTITIES ARE PER TRAILER

ITEM NO.	PART NUMBER	DESCRIPTION	QTY.
1	L04047	Light, ABS 2" Amber	1
2	G08005	Grommet 2" Light	5
3	C26165	Liquidtite 90	2
4	L04036	Light, 2" Amber LED	2
5	L04037	Light, 2" Red LED	2
6	B13048	Box, light Vertical	2
7	L04080	Light, License	1
8	G08010	Grommet, 4" Tail/Stop/Turn	4
9	L04305	Light, 4" Tail Stop Turn LED	4

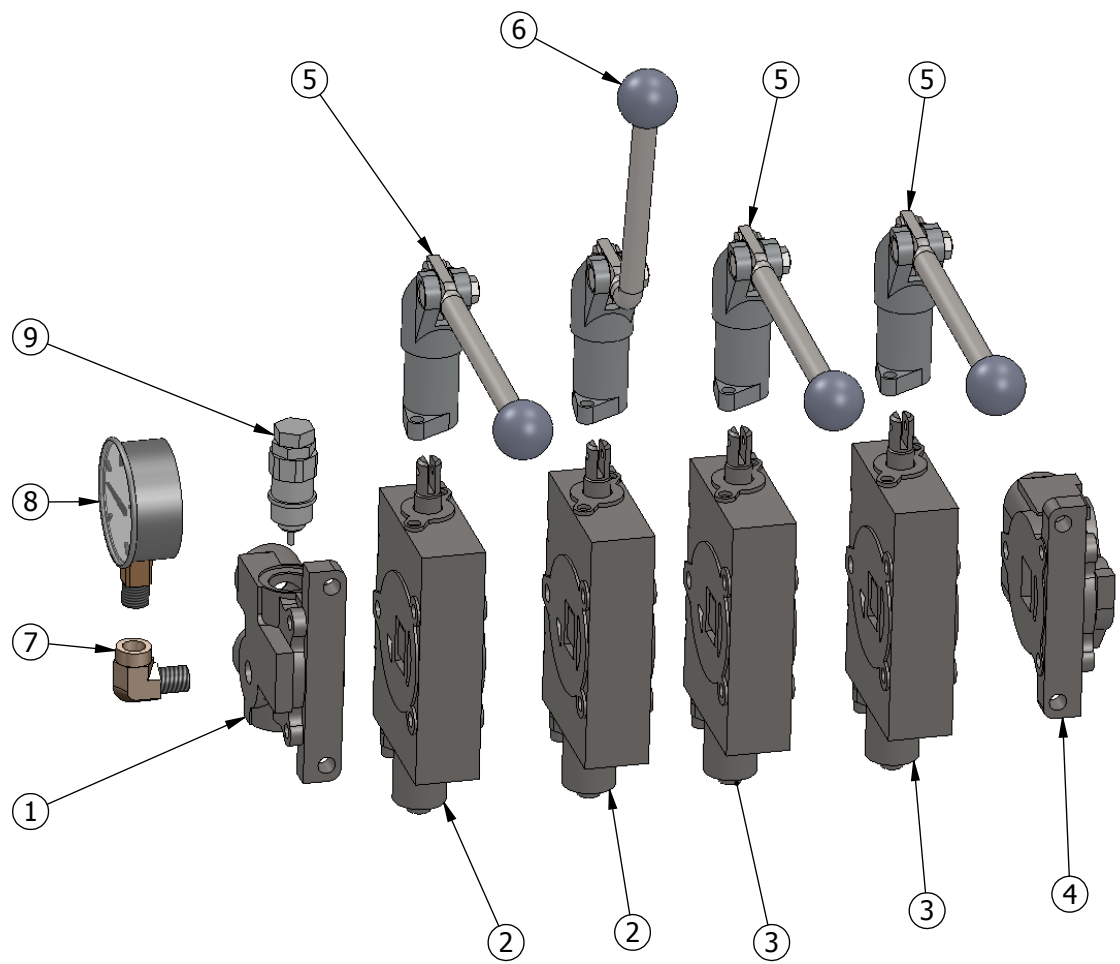

BOM Table			
ITEM NO.	PART NUMBER	DESCRIPTION	QTY.
1	V02138	Inlet w/o Relief	1
2	V02130	Double Acting	2
3	V02135	Single Acting	2
4	V02065	Outlet w/PB	1
5	B15910A	Handle, Straight	3
6	B15912A	90° lever assembly	1
7	F05150	Fitting, Street Elbow 4-4	1
8	G02055	3K bottom mount	1
9	V02150	relief valve	1

**IF items look different from the parts breakdown please call for assistance. (541)354-1001**

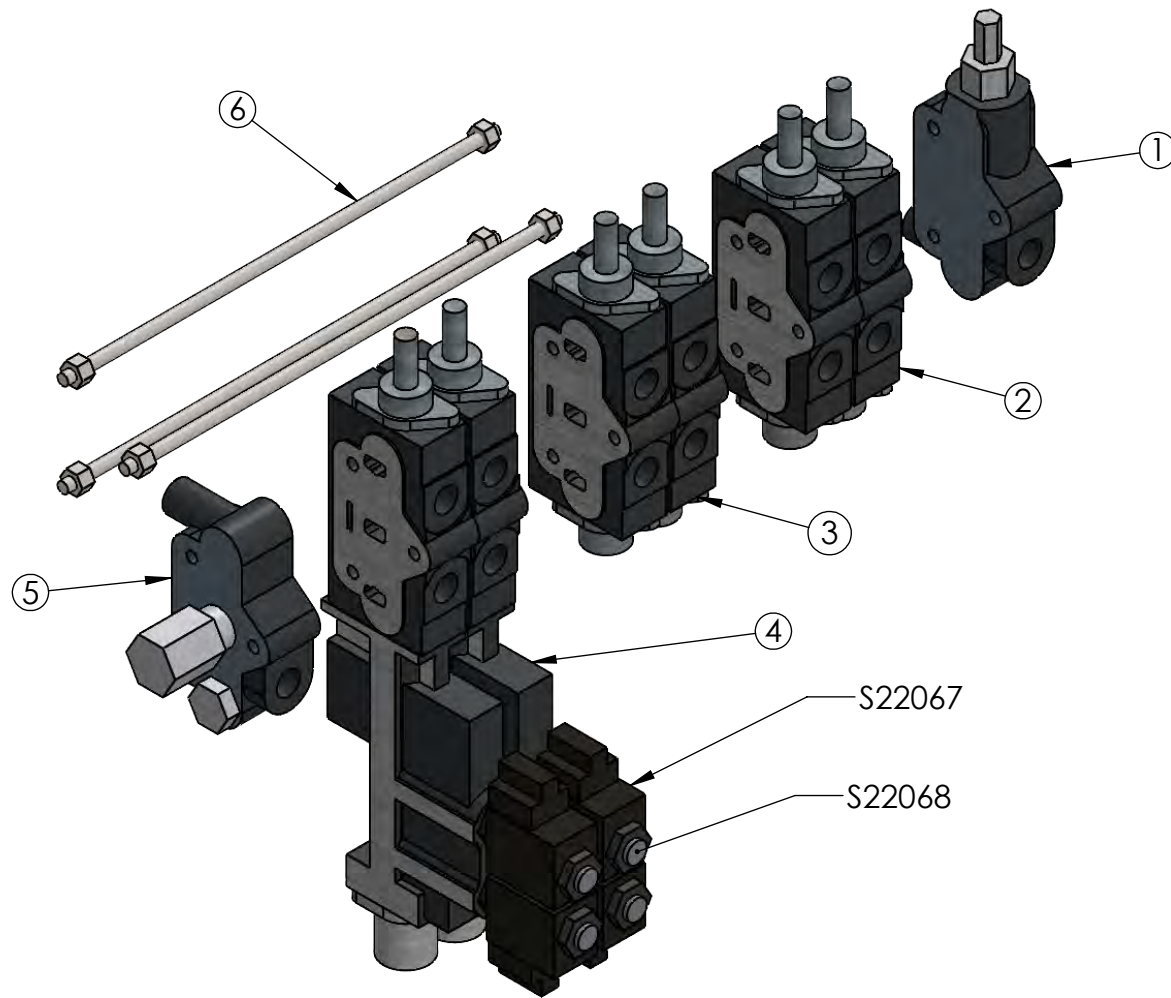

**B15947A**  
Bracket, Straight Prince Lever

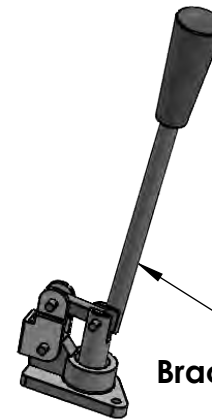

**B15948A**  
Bracket, 90° Prince Lever

Parts available for replacement:

S22067 - Coil only for V02103  
 S22068 - Cartridge only for V02103  
 K02073 - Seal kit for S22068

ITEM NO.	PART NUMBER	DESCRIPTION	QTY.
1	V02100	Valve Inlet w/relief Prince	1
2	V02101	Valve 4 Way Manual Prince	2
3	V02102	Valve 3 Way Manual Prince	2
4	V02103	Valve 4 Way Solenoid Prince	2
5	V02104	Valve Sec Outlet w/PB Prince	1
6	K02319	Kit, Rod 6-Bank Prince	1



**Prince Valve Bank**

## **Hogg & Davis Vehicle Specification - Model # Hydra 985**

<b>General:</b>	Latest Model, all new, single axle, cable pulling unit. Trailer to be engineered for safe, rapid, one-person operation. Trailer must accommodate both underground and overhead power systems.
<b>GVWR:</b>	21,980 lbs
<b>GAWR:</b>	20,000 lbs
<b>Overall Dimensions:</b>	Length – 198 inches Height – 80 inches Width – 96 inches std. (102” wide available) Weight – 7020 lbs
<b>Reel Capacity:</b>	Diameter – 108 inches Width – 56 inches ( <b>Wide unit can hold a 62” wide reel</b> ) Weight – 14,000 lbs.
<b>Frame:</b>	Heavy duty boxed angle, with boxed I-beam tongue.
<b>Axle:</b>	20,000 lb. capacity stub spindles with heavy duty Timken bearings for single wheel application.
<b>Brakes:</b>	16” x 5” full air w/ABS.
<b>Tires:</b>	315/80R22.5 20Ply TOYO Radial Tires w/Custom 10k Rim
<b>Rims:</b>	9.00 x 22.5 Custom Rim rated at 10,000# each. 10 on 11-1/4” BC - Balanced
<b>Power Unit:</b>	Yanmar Model 3TNV88, 30HP, 3 cylinder, water cooled diesel engine. Fuel tank is 9 gal and is equipped with proper filters. Key actuated with electric start. Backlit marine style gauges that include: tachometer, amp-meter, hour meter, fuel level, water temperature and oil pressure. <b>Interim Tier 4 Compliant</b>
<b>Transmission:</b>	Fully hydrostatic with two forward and two reverse speeds. Capable of shifting on the fly from low to high without stopping pull in progress. Joystick controlled with microswitch activation to prevent inadvertent operation.
<b>Hydraulics:</b>	15 gallon hydraulic oil tank with full flow filtration on suction and return lines. 0-3000 psi auxiliary pressure gauge at the control valve bank. 0-5000 psi hydrastatic pressure gauge at the front control panel.

- Reel Drive:** Capable of 24,000 lbs line pull at a 19 inch core diameter and 80 inch flange diameter reel. The drum drive is accomplished by 4 powered drive rollers that contact the cable reel flanges with 14,000 lbs of force. These rollers are adjustable for variable reel widths with a manually cranked screw.
- Drive Rollers:** Two drive rollers per flange. Roller cores and rubber rings are machined for press fit tolerance and can be pressed on and off for ease of maintenance.
- Aux Power Shaft:** Auxiliary power shaft located on curb side. Shaft is sized to accept standard type twist lock CR reels. Shaft is protected by cover and accessed through hinged door w/latch.
- Hyd Loading:** Mandrel lifting racks load reels up to 108" in diameter x 56" wide. Open yoke frame and multiple pocket lifts provide uniform ground clearance and allow reel to be carried low for better towing center of gravity. Lifts are stabilized and locked to relieve load from hydraulic system with weight transferred directly to main frame. Hydraulic cylinders to handle reels up to 20,000 lbs in weight.
- Reel Mandrel:** 2-1/2" diameter ETD-150 solid steel bar with nylatron bearings, two tapered centering cones and locking collars.
- Tongue Wheel:** Hydraulic powered, chain driven front idler wheel. The wheel is directionally controlled by means of a single joystick, allowing for mobility of the trailer without the use of another vehicle.
- Pintle Eye:** Adjustable pintle eye with 3" I.D. Clearance - Holland Model No. DB-1385.
- Jackstands:** Two cadmium-plated, self adjustable, quick-release. One at each rear corner of trailer to take load off tires when in use.
- Tool Boxes:** Two lockable boxes mounted in front of fenders, one on each side. T-handle type latches.
- Fenders:** 11 Gauge steel, over and down each side of the tires.
- Mud Flaps:** (2) Hogg & Davis logo mud flaps, one at rear of each tire.
- Safety Chains:** (2) 1/2" x 36" alloy steel with hooks.
- Wheel Chocks:** Four rubber chocks 10" long x 8" wide x 5" high w/handle.



**Lighting:** Trailer to have stop, tail, turn and marker lights. Wiring to be per ICC specifications. At trailer tongue, install a 7-wire socket with 36" whip. All wiring to be enclosed in hard conduit in the trailer frame. All lights to be double shock mounted Lexan lens with pigtails (FMVSS108).

**Paint:** Complete trailer to be grit blasted with GM50 size metal grit and primed with PPG DP-40 primer, with a finish coat of PPG Polyurethane paint to be a minimum of 3 mils in coverage. Parts are then baked to final curing at 150 degrees for one full hour. All parts on the trailer are to be painted before they are assembled.

**Warranty:** Trailer mainframe to have warranty against defects in material and workmanship for a period of 15 years from date of shipment. Trailer to have a 15-month new equipment warranty on all other parts due to defect or workmanship.

**Manuals:** Two: Containing parts, service, and operations.

### ***Optional Equipment:***

**Fail Safe Brake:** Dual caliper brake w/ 16" ventilated disc.

**Tool Circuit:** Auxiliary hydraulic tool circuit available for light duty tool use. 10 GPM pump with quick disconnects at rear of trailer.

**Hyd Outriggers:** Hydraulic operated rear stabilizers can be added in place of the standard mechanical jackstands.

**Levelwind:** An optional levelwind is available for winding cable onto drums. Controlled by electric solenoid valve with detented micro switch. The unit swings out of the way to allow for reel loading. Easily removed with pins and quick disconnects.

**Aux. Capstan:** An optional capstan is mounted on the street side rear fender. Approx. 100fpm and 100 lbs. of line pull. Controlled by electric solenoid valve with detented micro switch.

**Beacon Lights:** Fixed or telescoping pole mounted amber strobe lights mounted at each corner of power unit screen.

**LED Lights:** LED light package available.

**Hose Reels:** Fender mounted , retractable, dual hydraulic hose reel w/25' hoses.

**Urethane Rollers:** Four Urethane Drive Rollers.

# 985 Control Panel

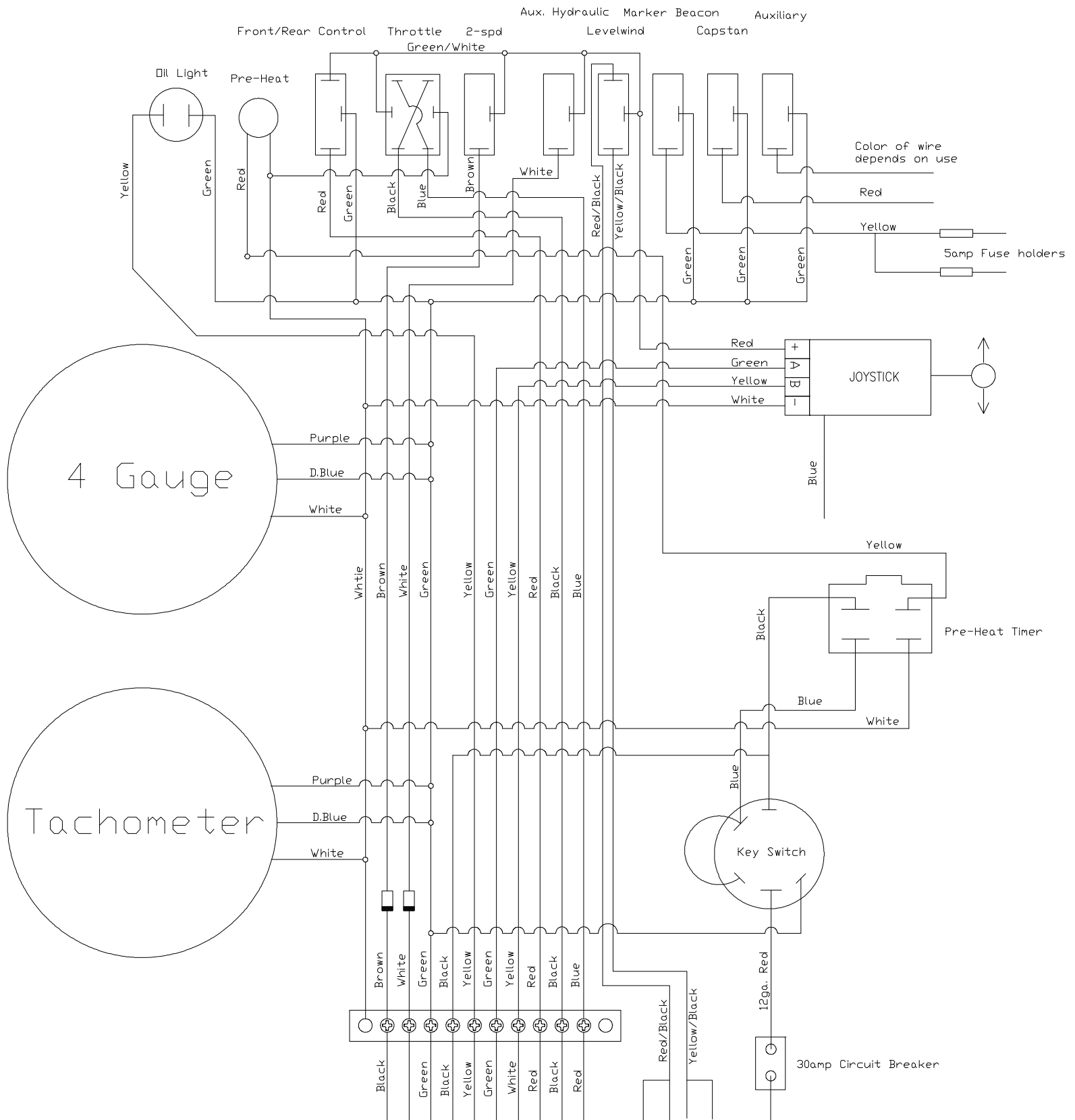

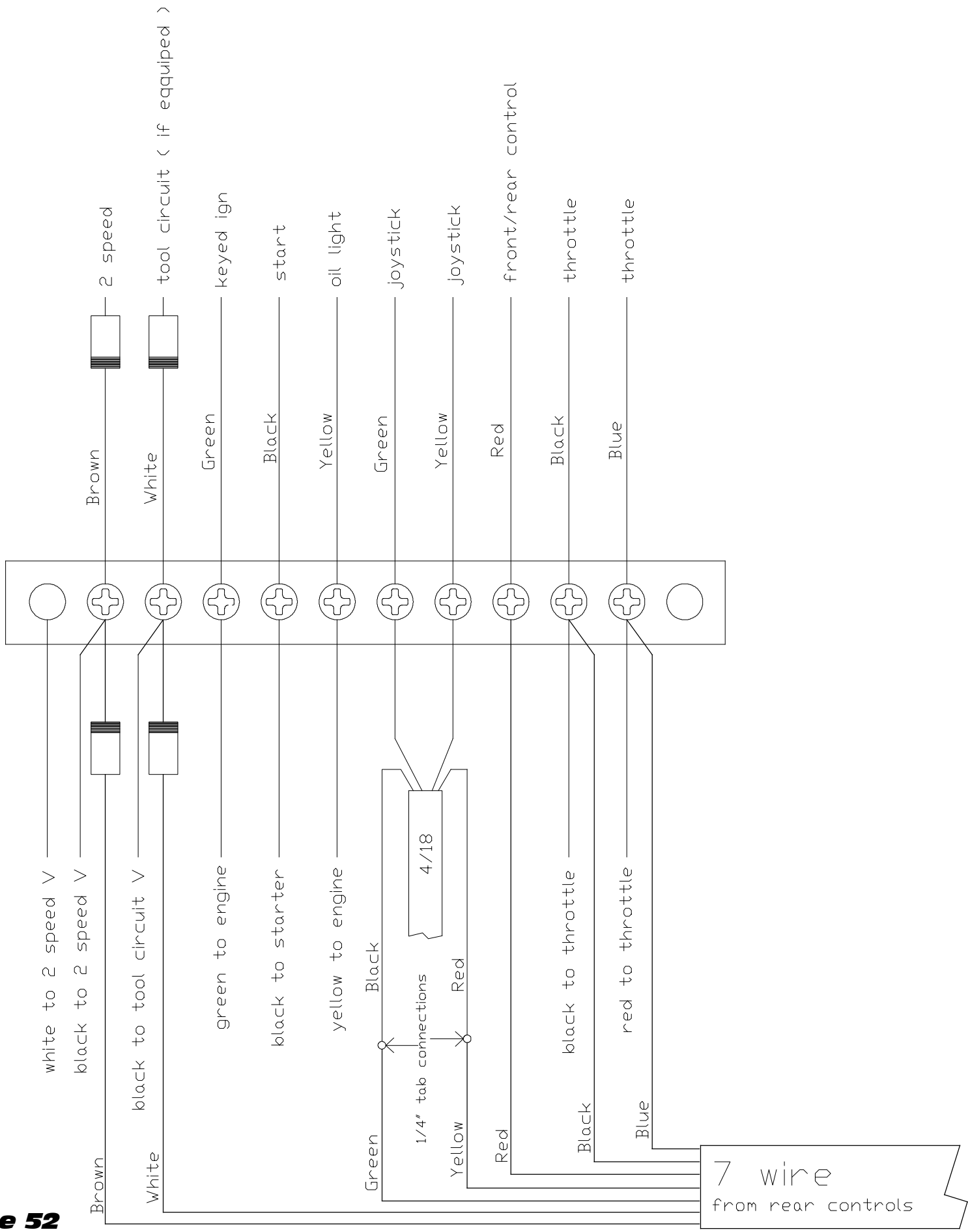

On units not equipped with a tool circuit the white wire will go to ground

6500/985 Rear Control Wiring (pre-LOFA)

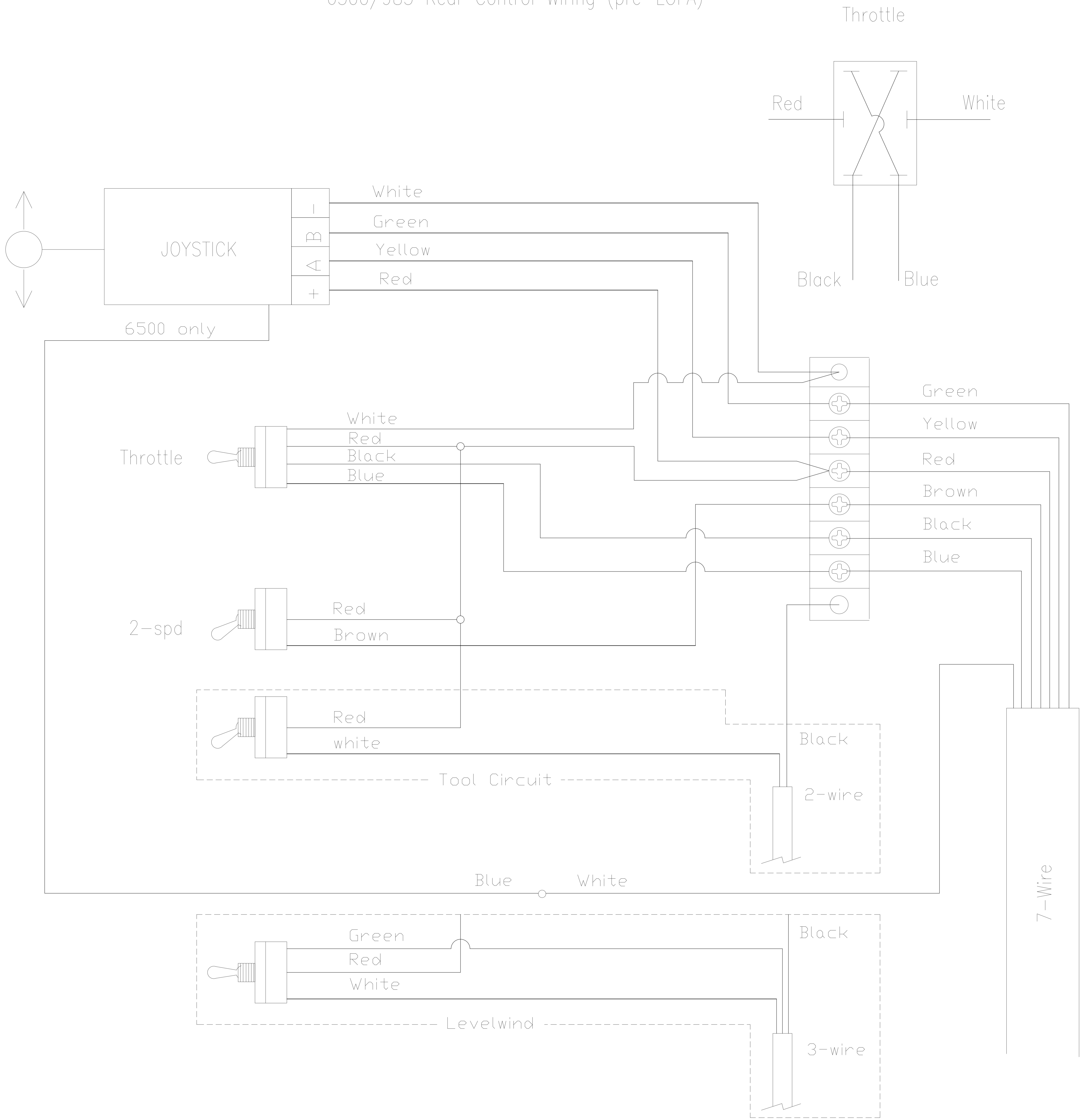

# 985 3-TNV ENGINE WIRING

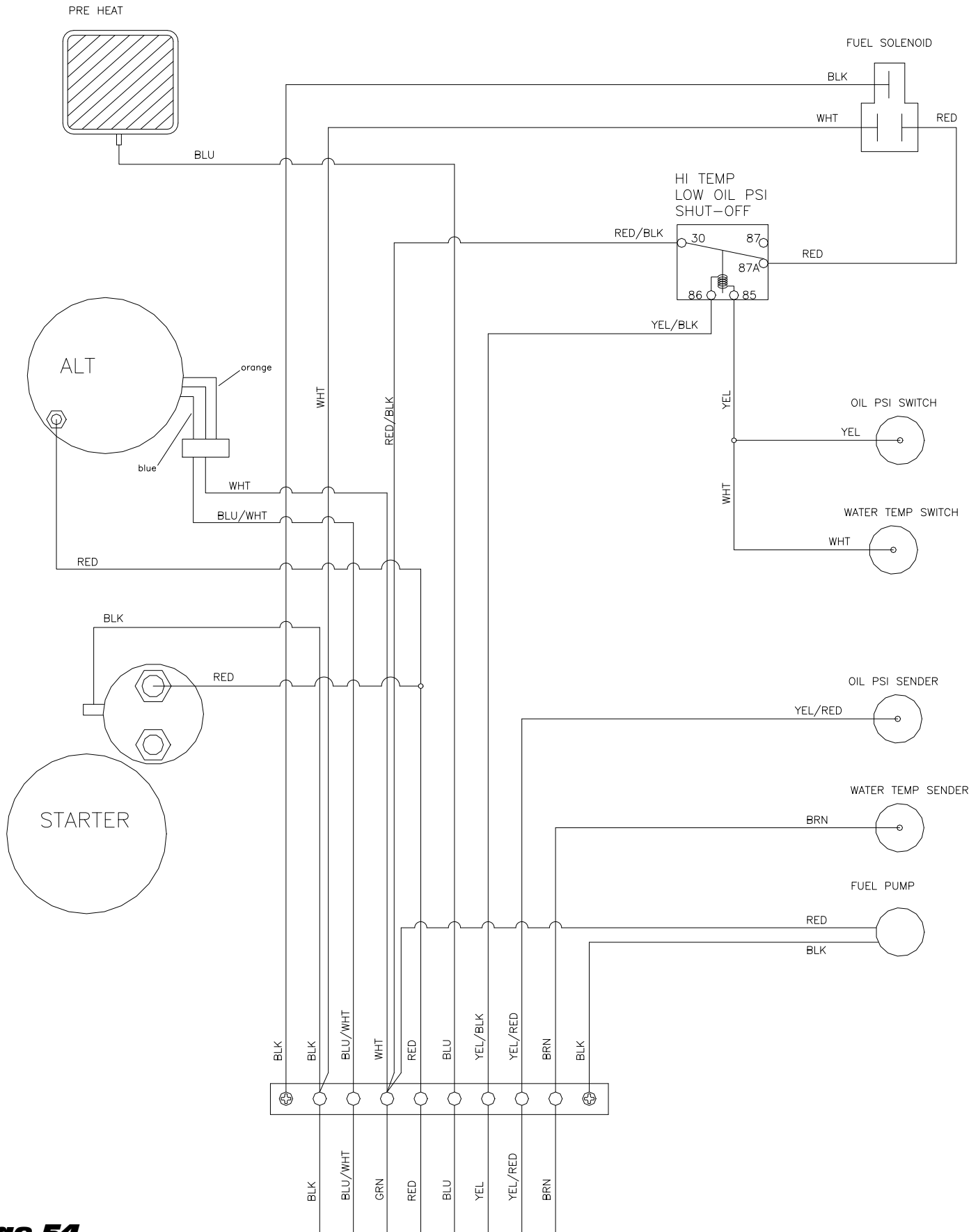

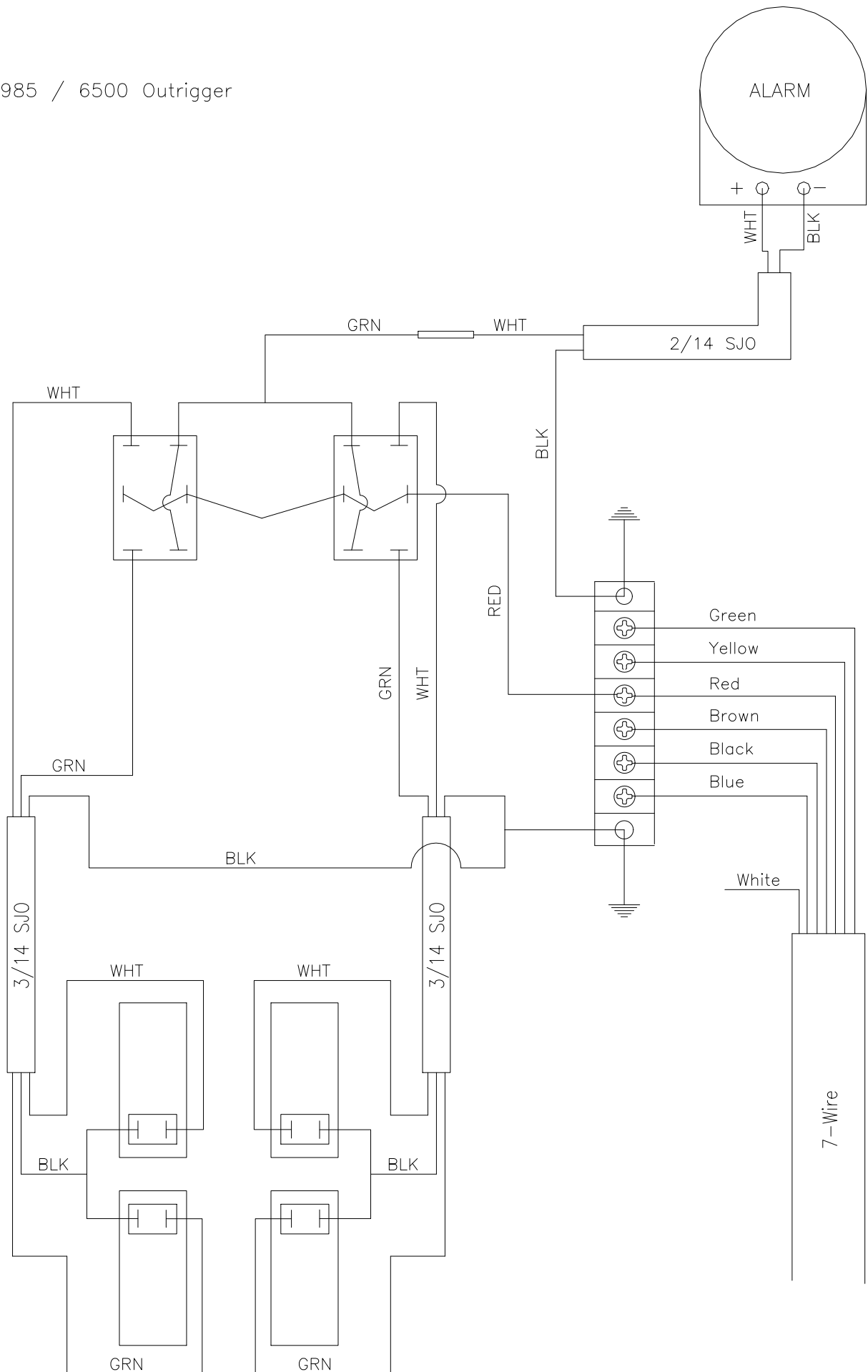

# 985 Control Wiring Keyed Ignition and throttle relays

Wires for original throttle switch  
 factory - HD  
 brown - brown  
 white/red - white  
 black - black

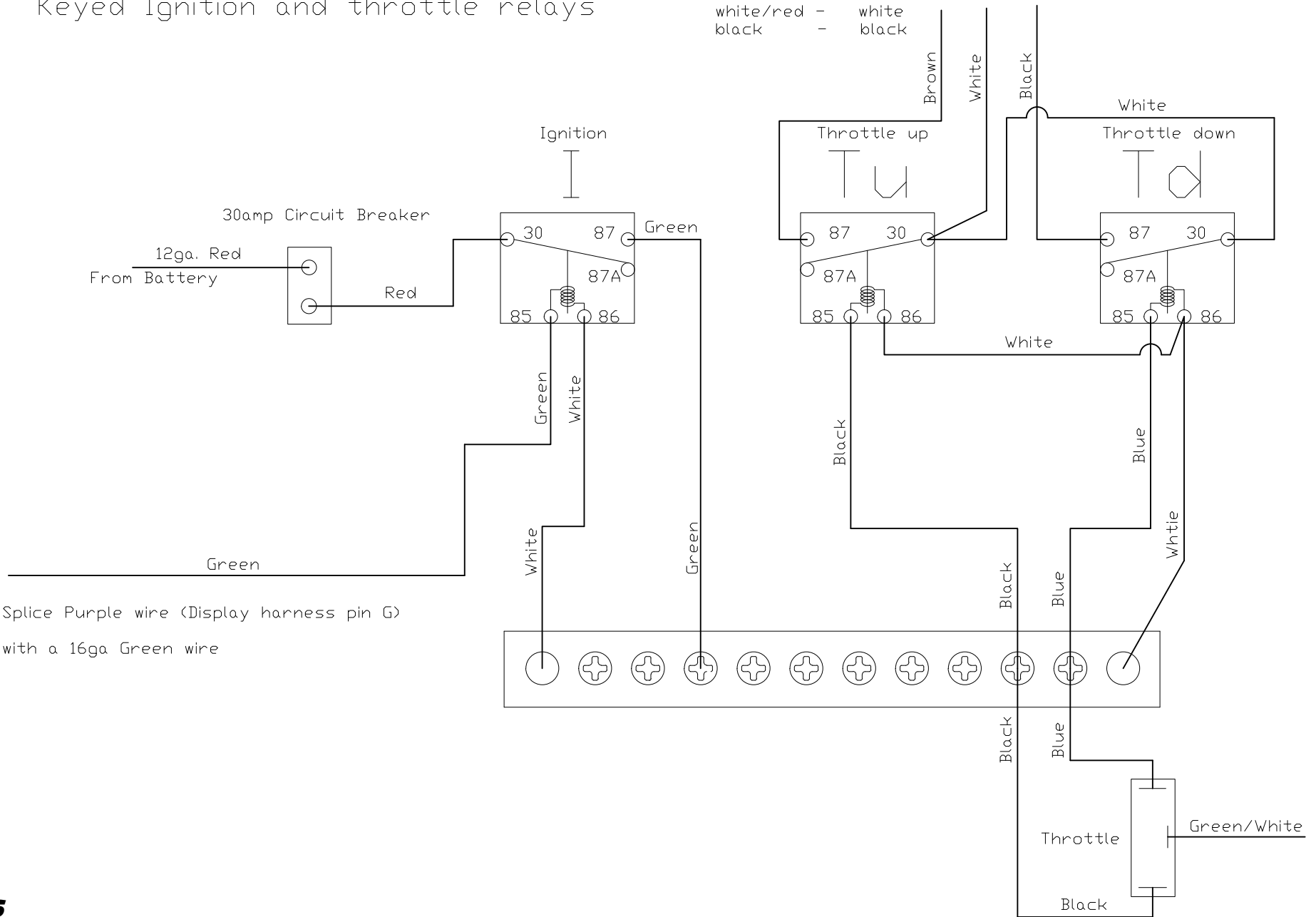

# 985 Control Panel T4f Switches

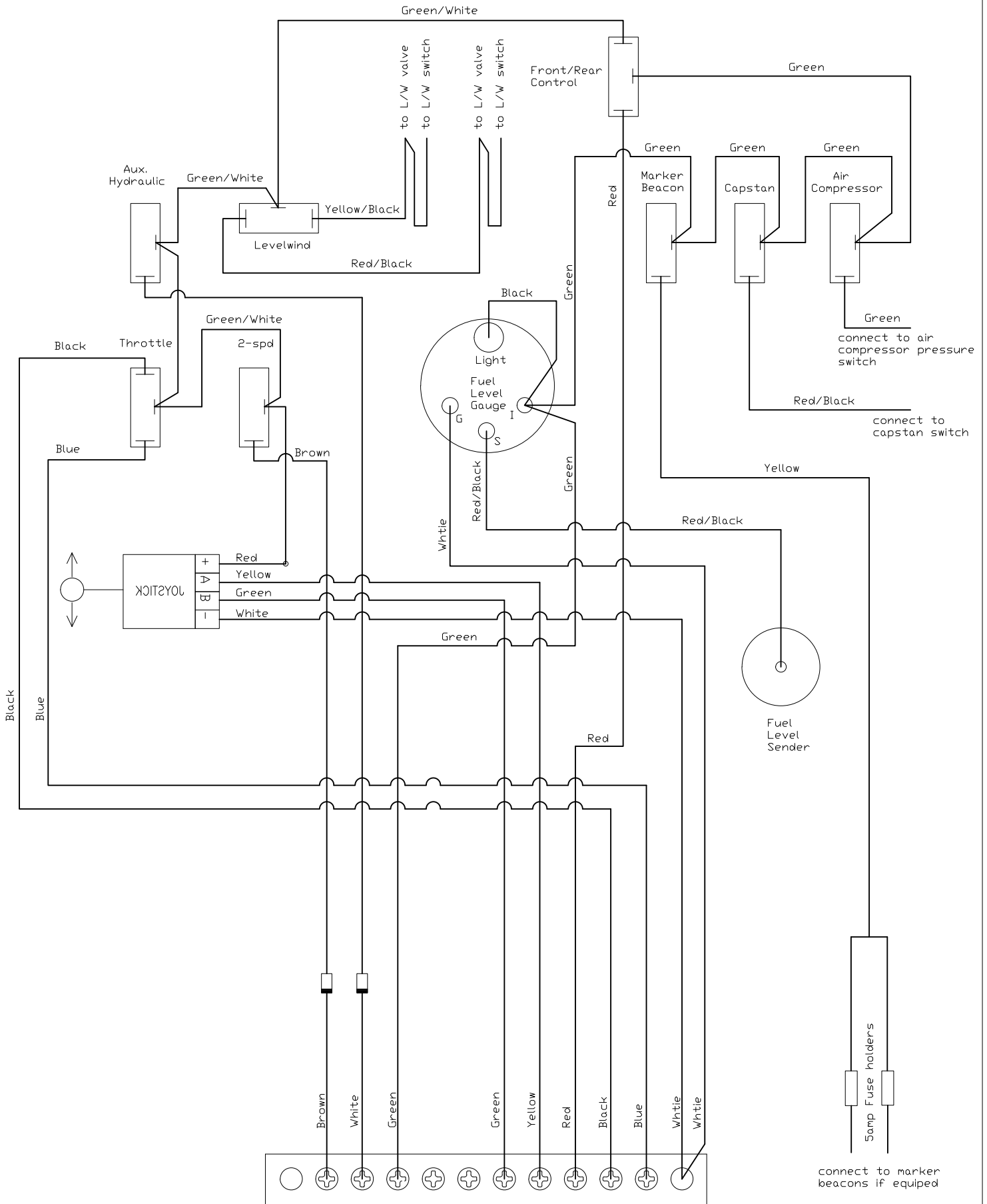



# 985 Control Panel Valves T4f

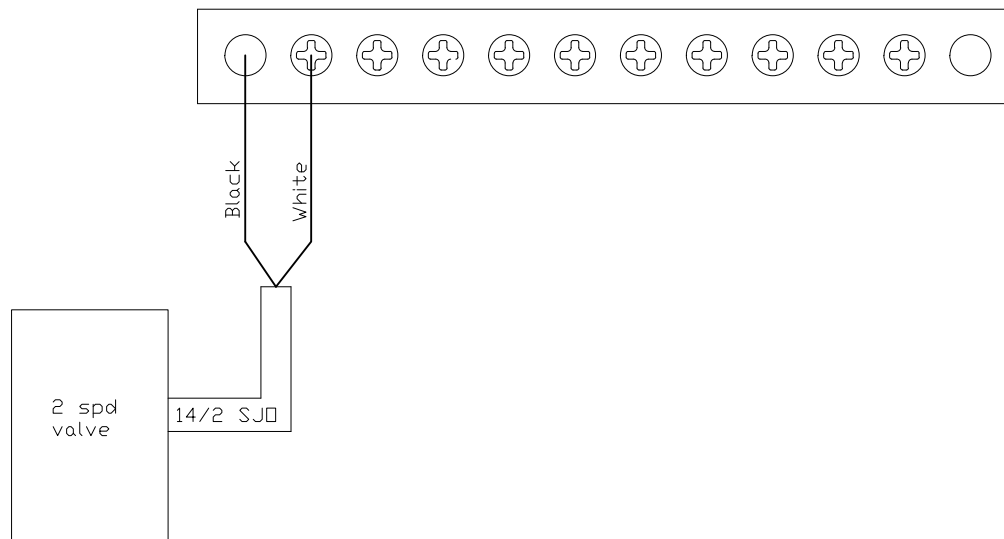

# 985 Lower Control Panel T4f

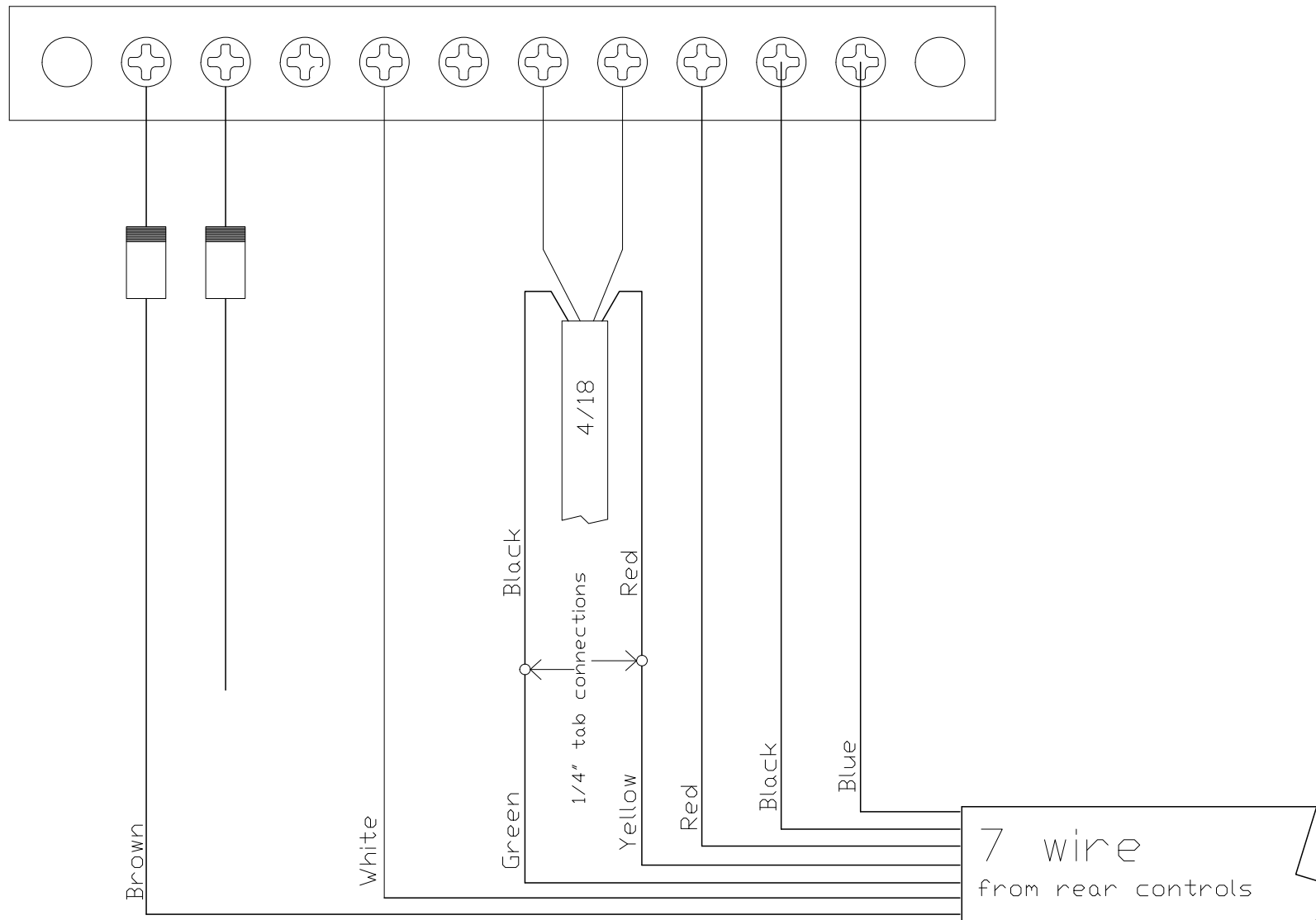

Tool Circuit equipped units require a 14/2 SJW to be run along with the 7 wire  
Level Wind equipped units require a 14/3 SJW to be run along with the 7 wire

# 985 Rear Control Wiring T4f

if the unit has a tool circuit you must run a 14/2 SJD  
if the unit has a level wind you must run a 14/3 SJD

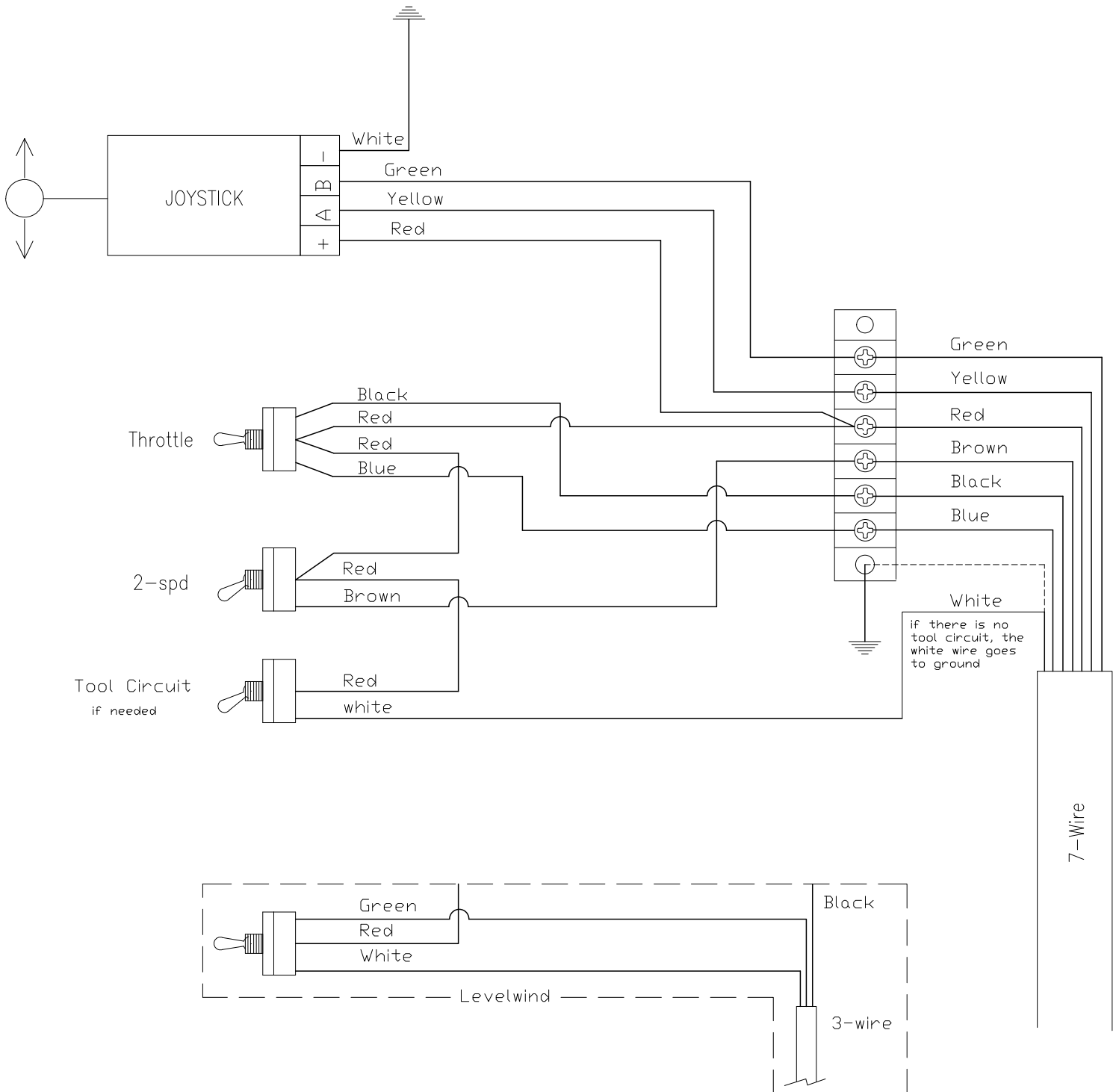

# 985B Control Panel T4f Switches

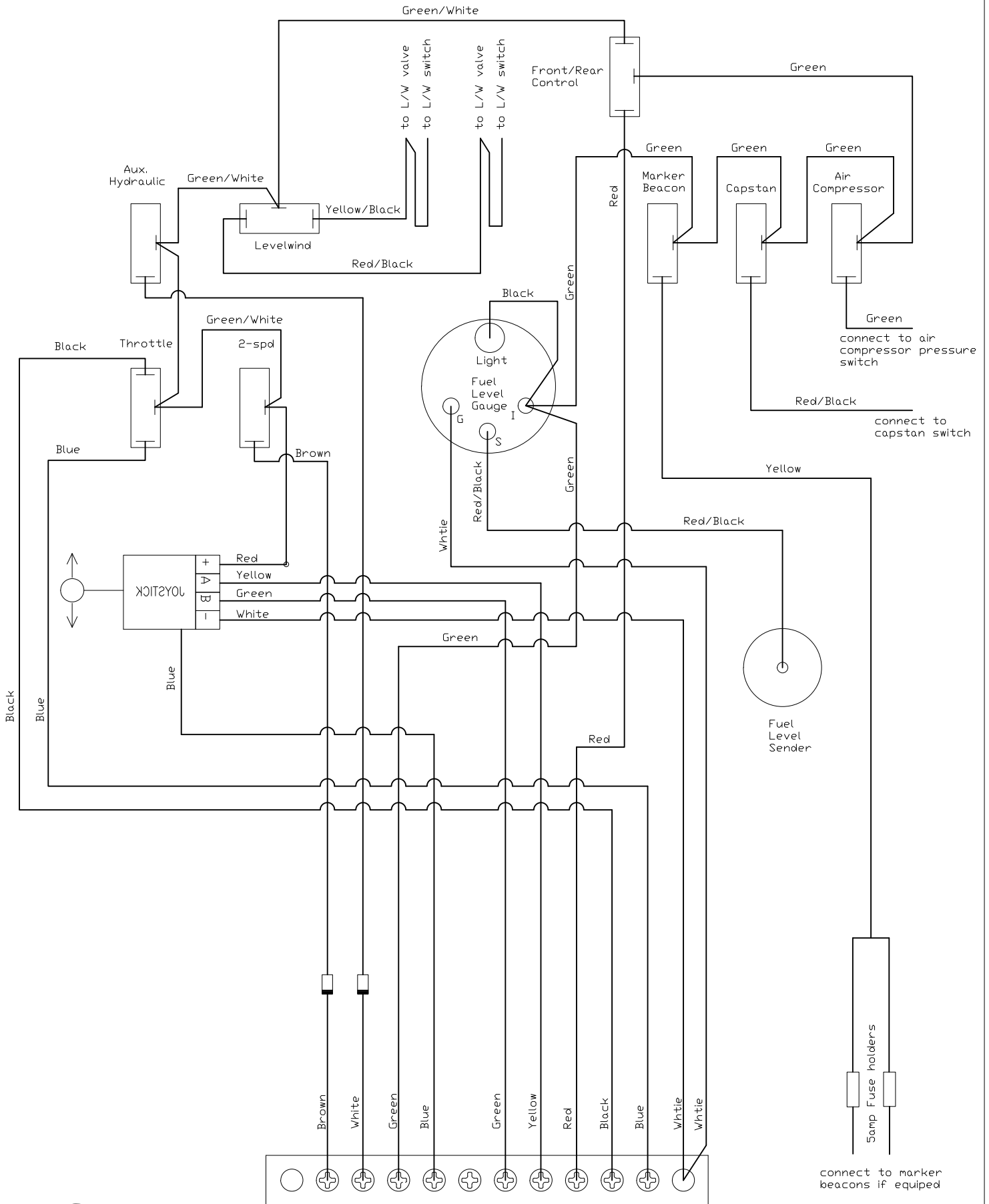

# 985B Control Panel Valves T4f

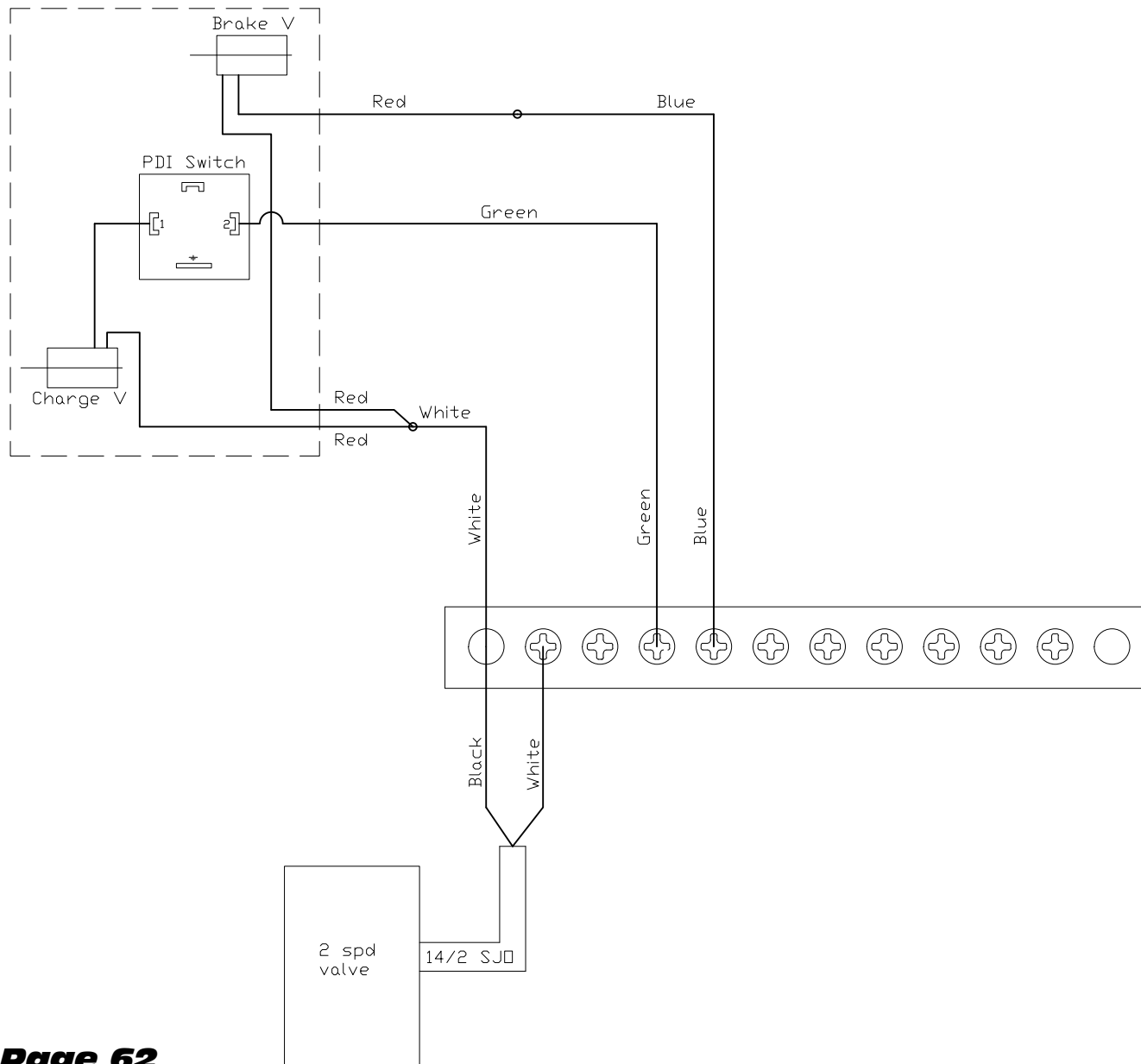

# 985B Rear Control Wiring T4f

if the unit has a tool circuit you must run a 14/2 SJD  
if the unit has a level wind you must run a 14/3 SJD

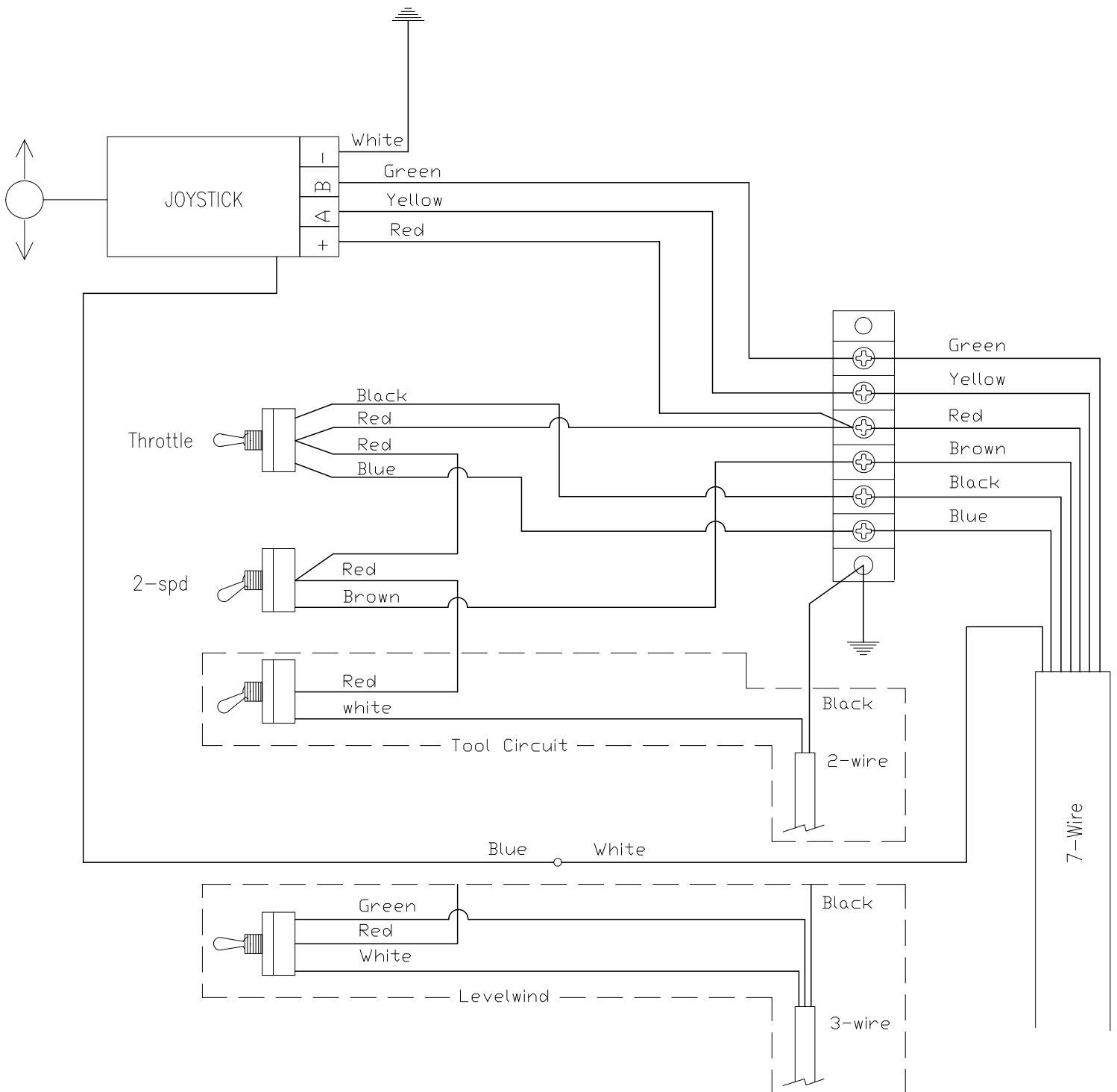



# Torque Specifications



## HUBS (For Ball Seat Mounted Disc Wheels) 6 and 10 Stud Hubs

Applies to 3/4-16 and 1 1/8-16 Fastener Sizes

**RECOMMENDED TORQUE DRY: 450-500 ft. lbs.**

**INNER CAP NUTS** - First tighten cap nuts to 50 ft. lbs. using sequence shown. Then tighten cap nuts to recommended torque (450-500 ft. lbs. DRY) using sequence shown.

**OUTER CAP NUTS** - First tighten cap nuts to 50 ft. lbs. using sequence shown. Then tighten cap nuts to recommended torque (450-500 ft. lbs. DRY) using sequence shown.

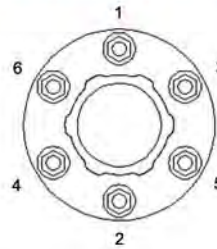

6-STUD

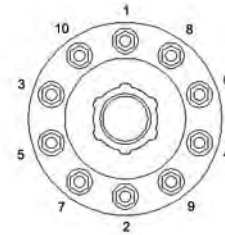

10-STUD

Recheck torque after first 50 to 100 miles of service and retorque as required to recommended torque specifications.

NOTE: In all applications where an aluminum disc wheel is to be installed, a special inner cap nut must be substituted for the standard inner cap nut.



## HUBS (For Pilot Mounted Disc Wheels) 8 and 10 Stud Hubs

Applies to M22 x 1.5 studs/two piece flange nuts

**RECOMMENDED TORQUE: 450-500 ft.lbs.**

All threads are right hand metric.

First tighten flange nuts to 50 ft. lbs. using sequence shown.

Check disc-wheels for proper positioning on pilots and proper seating against flange.

Then tighten flange nuts to recommended torque (450-500 ft. lbs.) using sequence shown.

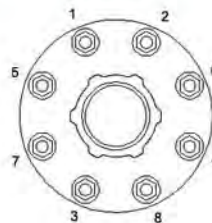

8-STUD

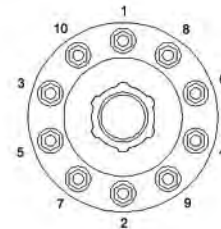

10-STUD

Recheck torque after first 50 to 100 miles of service and retorque as required to recommended torque specifications.



## SPOKE WHEELS

Applies to 3/4-10 Fastener Sizes

**RECOMMENDED TORQUE DRY: 200-260 ft. lbs.**

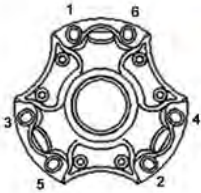

3 SPOKE

TIGHTEN CLAMPS  
EVENLY  
IN THIS ORDER

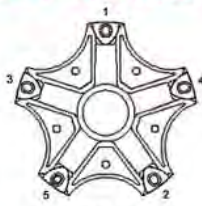

5 SPOKE

TIGHTEN CLAMPS  
EVENLY  
IN THIS ORDER

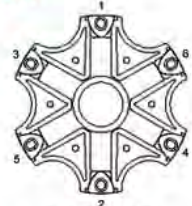

6 SPOKE

Recheck rim nut torque after first 50 to 100 miles of service and retorque as required to recommended torque specifications.

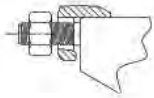

Heel-less clamps do not depend on a fulcrum at the bottom of the clamp to produce the force to wedge the rims.

Heel of clamp does not touch wheel.

HEEL-LESS CLAMP

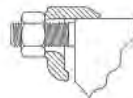

Gap permissible but not required - if gap exceeds 1/4" or if clamp bottoms out before reaching 80% of recommended torque, check to insure that the proper clamps and spacer are being used.

HEEL TYPE CLAMP

**IMPORTANT: Do not overtorque! Rim clamp does not have to heel. Overtorquing can deform rim spacer and damage back flange.**



## BRAKE DRUM or ROTOR ASSEMBLY TORQUE SPECIFICATIONS for Mounting Bolts (Grade 8 Fasteners)

Thread Size		Torque Requirements Foot Pounds		Thread Size		Torque Requirements Foot Pounds	
		Minimum	Maximum			Minimum	Maximum
5/8-18 (Tapped Holes)	Rotate Bolt	150	200	3/4-16 (Wheels)	Rotate Nut	275	300
5/8-18 (Through Holes)	Rotate Nut	150	175	3/4-16 (Hubs)	Rotate Nut	100	225
3/4-10	Rotate Nut	250	275	1-14	Rotate Nut	175	225

Note: All fastener parts must be clean and dry.

# ! WARNING

This brochure contains information taken from our Installation, Service and Safety Instructions Manual. Copies of the complete manual can be obtained at no cost by contacting our Sales Department at the address shown below.

Read and Understand the Installation, Service and Safety Instructions Manual before installing or servicing the hub. Failure to do so may result in personal injury or death, and may result in a compromise of your vehicle's safety through loss or failure of a wheel or compromise of the braking system.

The symbol shown above is used to call your attention to instructions concerning your personal safety and the safety of others. Watch for this symbol. It points out important safety precautions. It means "ATTENTION! Become Alert! Your personal safety is involved!" Read the message that follows and be alert to the risk of personal injury or death.

"The employer shall instruct each employee in the recognition and avoidance of unsafe conditions and the regulations applicable to his work environment to control or eliminate any hazards or other exposure to illness or injury." Ref: 29CFR 1926.20 (b) (4) (a) (2)

It is understood that safety rules within individual companies vary. If a conflict exists between the material contained in the manual and the rules of a using company, the more stringent rules should take precedence.

Webb Wheel Products, inc. Aftermarket Business Unit [www.webbwheel.com](http://www.webbwheel.com)





D30001  
(2)



D30009  
(1)

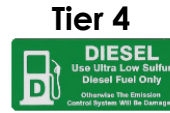

D30027  
(1)



D30010  
(1)



D30015  
(1)

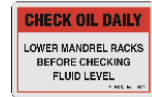

D30032  
(1)

**HOGG & DAVIS, INC**  
www.hoagadavis.com

D30018  
(2)

# HYDRA 985

D30038  
(2)



D30034  
(2)



D30022  
(1)



D30021  
(1)

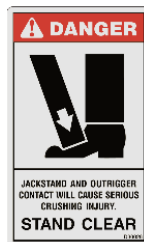

D30026  
(2)



D30028  
(5)

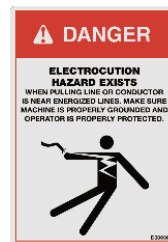

D30036  
(3)



D30037  
(1)



D30042  
(8)



D30069  
(1)



R09043  
(4)



R09044  
(2)



D30031  
(1)

Decal Kit # D30122

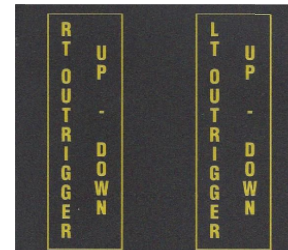

(1)

(1)

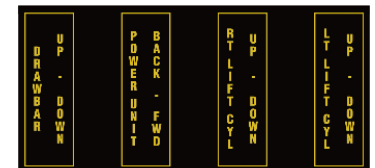

# LOADING INSTRUCTIONS

**IMPORTANT:** This unit is designed to load a reel that is setting on the ground. **DO NOT LOAD WITH FORKLIFT** or other device as this causes cable damage and can effect the safe carrying procedures of this unit. **FOLLOW DIRECTIONS.**

## LOADING PROCEDURE

NOTE: This dolly will accept reels of 50" to 100" in diameter and 25' in length to 85' in maximum in width.

1. To load, make sure power driving unit is lowered as far as possible.
2. Lower mandrel lift to bottom.
3. Pull up mandrel lock rods, remove mandrel and install in reel.
4. If reel bore is over 2-1/2" in diameter, use tapered cones for centering.
5. Always center mandrel in reel so that reel will be centered in dolly.
6. Install lock collar on each side of reel.
7. Place bearing on ends of mandrel.
8. Roll reel into unit or onto a winch saddle reel into lifting racks. Insert mandrel into lowest rack possible.
9. Put bearing block in place on each end of mandrel to hold bearings.
10. Insert mandrel lock rods through rack and bearing block.
11. Set eyeline locks, one on each side. These are located at rear of fenders. Push handle down to engage.
12. Raise reel until locks snap in place.
13. Lower reel with both valves and hold for 30 seconds to take load off driving cylinders. Raise should be setting on locks.
14. Adjust each set of drive wheels to center on reel flanges.
15. See instructions for adjusting rollers for proper reel diameter.
16. Move power unit against reel flange before towing this dolly.



## BEFORE TOWING VEHICLE

NOTE: With reels that have a single spoke (note drawing following), have spoke in vertical position before moving power unit against flanges.



D30002 (1)

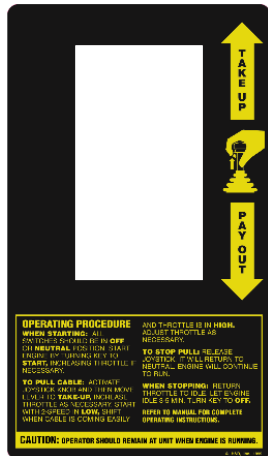

D30111 (1)

# HYDRA-HOG



D30003 (1)

# HOGG & DAVIS

D30019 (1)



D30025 (1)



D30030 (1)

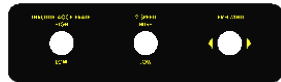

D30029 (1)



D30128 (1)

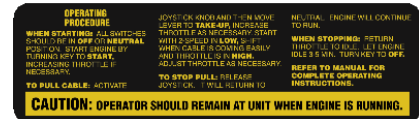

D30020 (1)



D30024 (1)

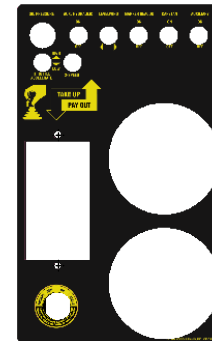

D30039 (1)

## Tier 4

## Tier 4



D30151 (1)

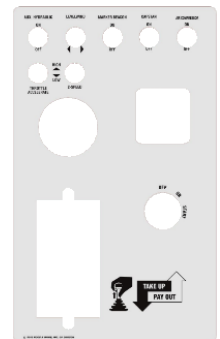

D30150 (1)

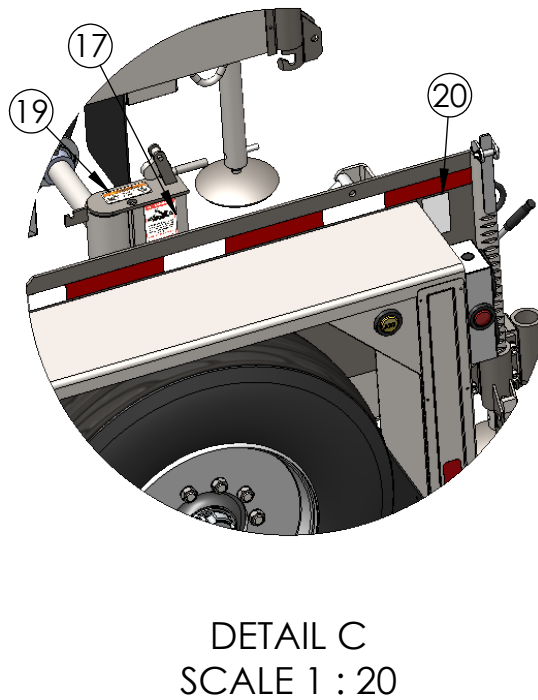
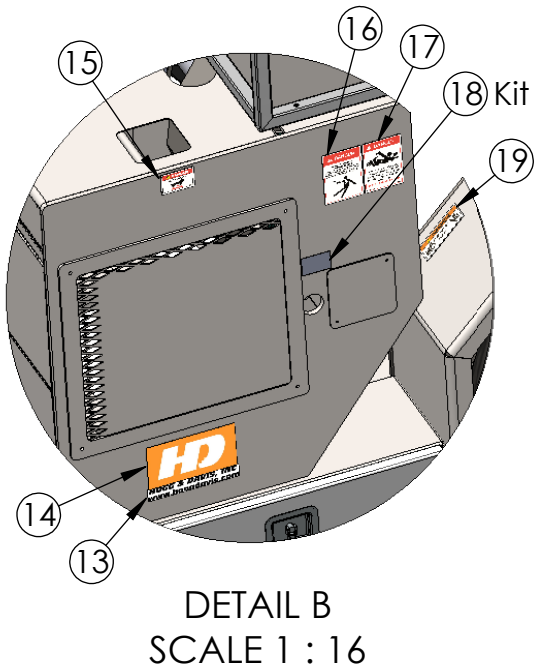
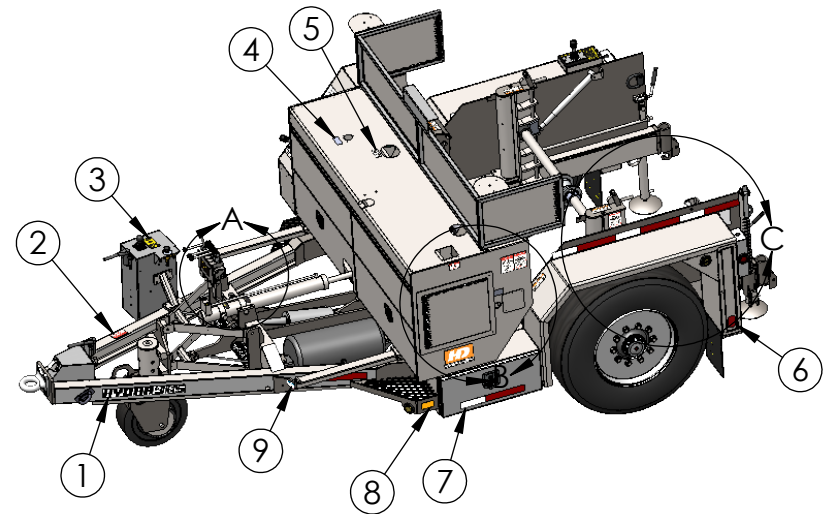
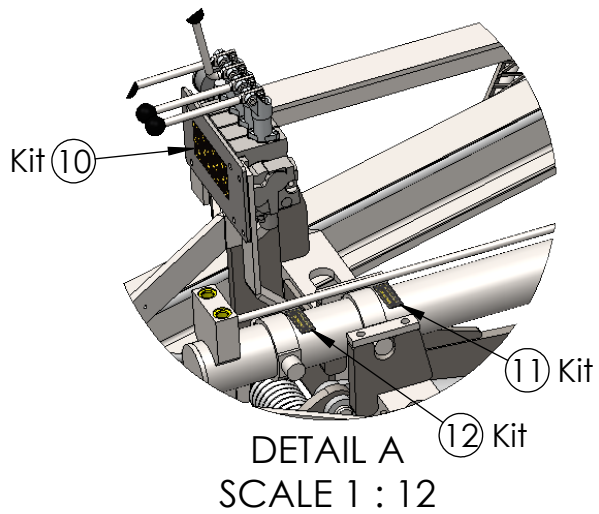

ITEM NO.	PART NUMBER	DESCRIPTION	QTY.
1	D30038	Decal, Hydra 985 Tongue	2
2	D30037	Decal, Important - Idler Wheel	1
3	D30025	Decal, Steer-Go Directions	1
4	D30027	Diesel Ultra Low Sulfur	1
5	D30010	Decal, Hydraulic Fluid Only	1
6	R09043	Reflector, Red 2x3-1/2	4
7	T19001	Red/White Reflective tape	10
8	R09044	Reflector, Amber 2x3-1/2	2
9	D30034	Decal, Grounding Lug	2
10	D01013	In Kit# D30122	1
11	108 inch Reel	In Kit# D30122	1
12	96 inch Reel	In Kit# D30122	1
13	D30018	Decal, HD 1/2" x 9"	2
14	D30001	HD Logo 6x9	2
15	D30015	Decal, Hot Surface	1
16	D30036	Decal, Electrocution Hazard	3
17	D30028	Decal, Danger Twisty Man	5
18	DR Adjust	In Kit# D30122	2
19	D30042	Decal, Keep Hands Clear	8
20	D30026	Decal, Danger Stand Clear	2

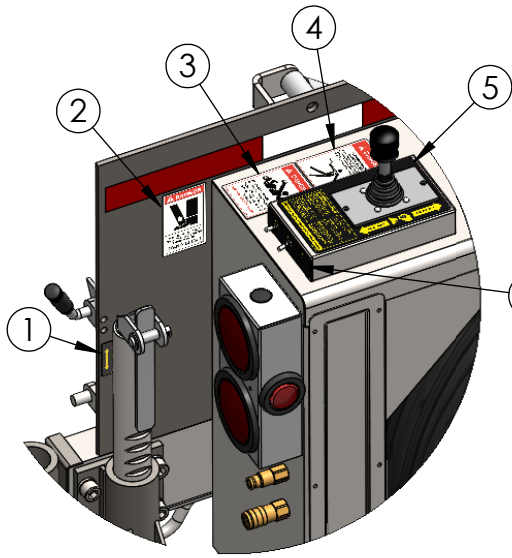

DETAIL A  
SCALE 1 : 12

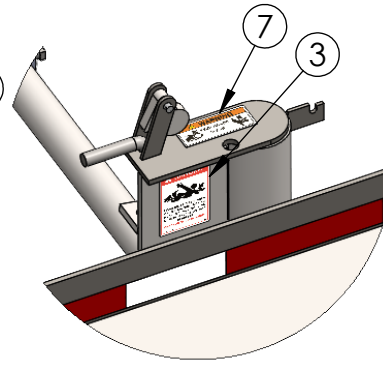

DETAIL C  
SCALE 1 : 12

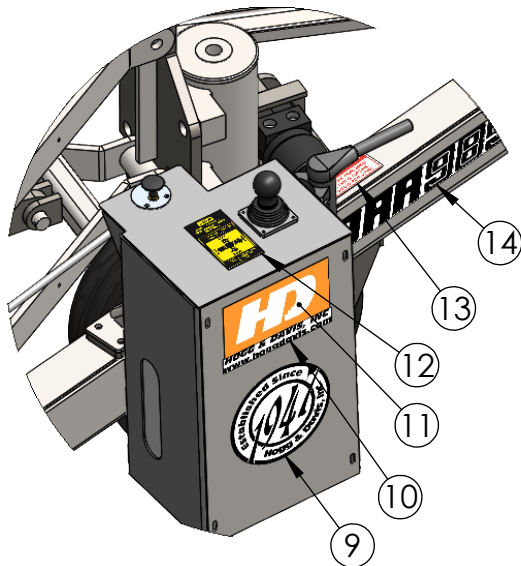
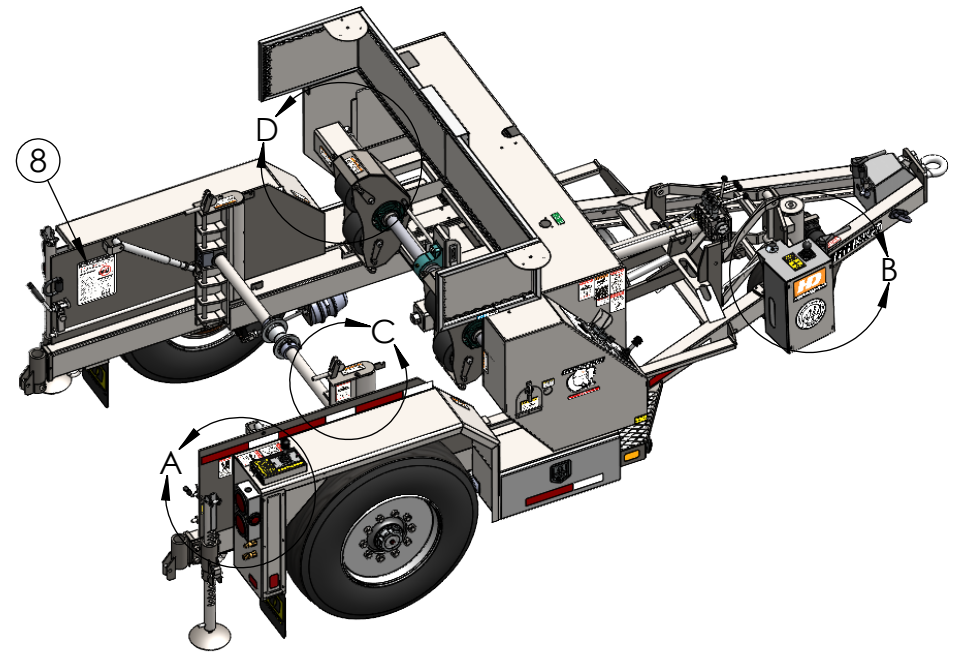

DETAIL B  
SCALE 1 : 12

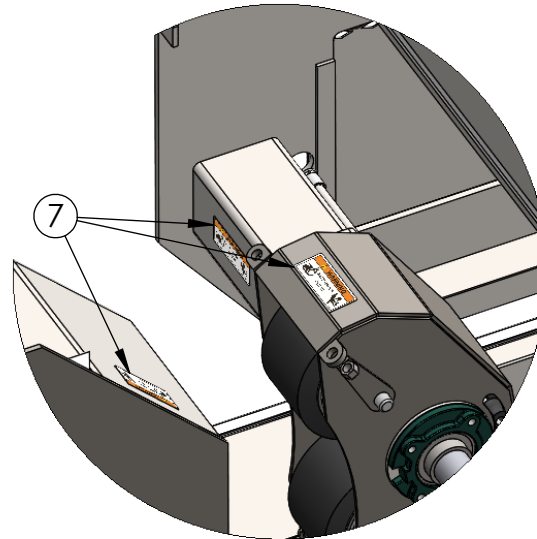

DETAIL D  
SCALE 1 : 12

ITEM NO.	PART NUMBER	DESCRIPTION	QTY.
1	lock unlock L	In kit #D30122	1
2	D30026	Decal, Danger Stand Clear	2
3	D30028	Decal, Danger Twisty Man	5
4	D30036	Decal, Electrocution Hazard	3
5	D30111	Decal, Rear Control	1
6	D30030	Decal, Rear Ctrl - Aux Hyd	1
7	D30042	Decal, Keep Hands Clear	8
8	D30002	Decal, Loading Instructions	1
9	D30128	Established 1947	1
10	D30018	Decal, HD 1/2" x 9"	2
11	D30001	HD Logo 6x9	2
12	D30025	Decal, Steer-Go Directions	1
13	D30037	Decal, Important - Idler Wheel	1
14	D30038	Decal, Hydra 985 Tongue	2
59	D30150	Decal, Control Panel T4f	1

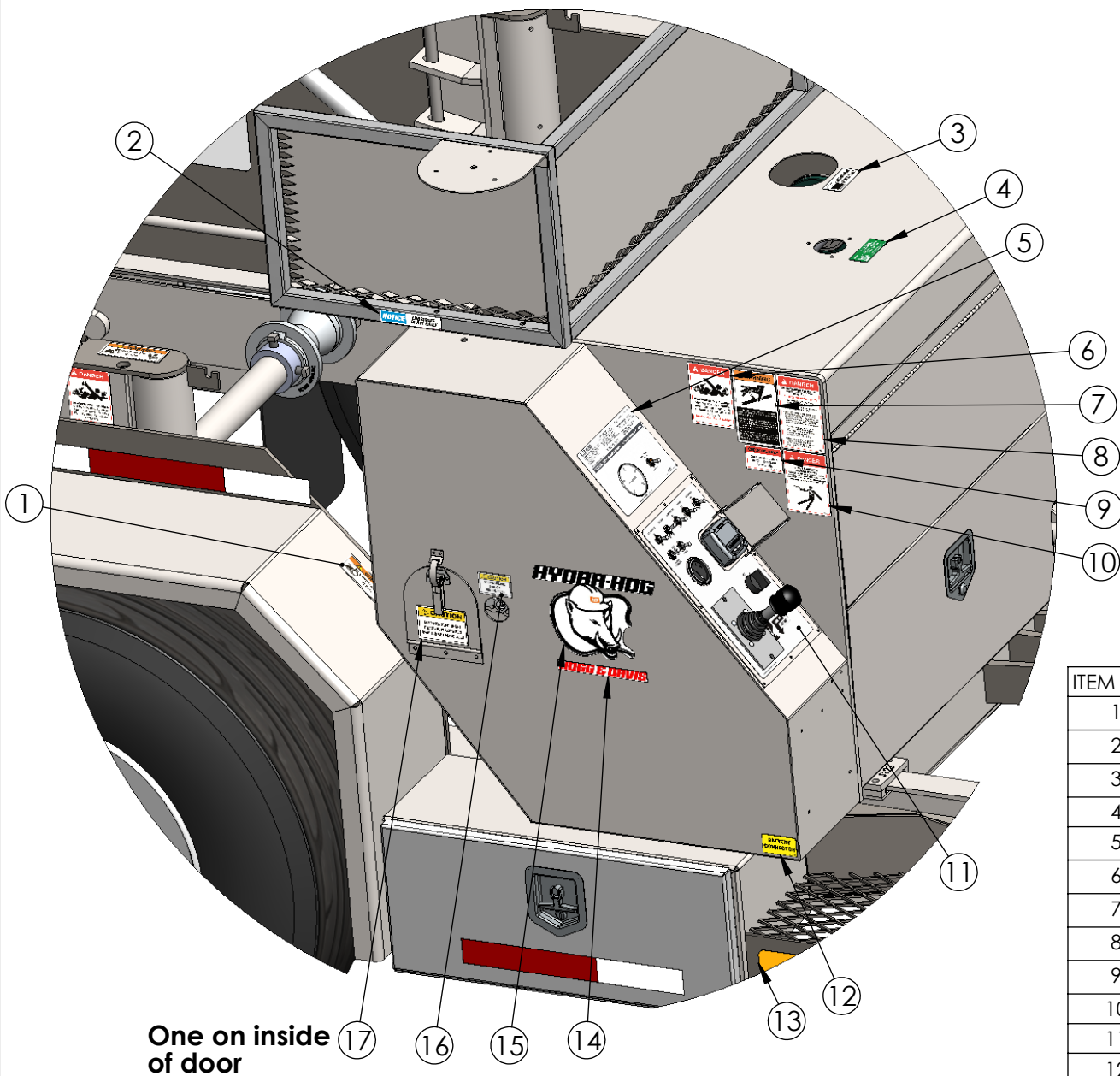

One on inside  
of door

ITEM NO.	PART NUMBER	DESCRIPTION	QTY.
1	D30042	Decal, Keep Hands Clear	8
2	D30069	Decal, Lubricate Chain Daily	1
3	D30010	Decal, Hydraulic Fluid Only	1
4	D30027	Diesel Ultra Low Sulfur	1
5	D30151	Decal, Control Panel Hydrostatic	1
6	D30028	Decal, Danger Twisty Man	5
7	D30022	Decal, Danger Fluid Pressure	1
8	D30021	Decal, Untrained Operator	1
9	D30032	Decal, Check Oil Daily	1
10	D30036	Decal, Electrocution Hazard	3
11	D30150	Decal, Control Panel T4f	1
12	D30031	Decal, Battery Connector	1
13	R09044	Reflector, Amber 2x3-1/2	2
14	D30019	Decal, HD 3/4"x9" Red	1
15	D30003	Decal, Hydra Hog 10"x7"	1
16	DR Adjust	In Kit# D30122	2
17	D30023	Decal, Caution Extended Shaft	1